

Locking Device

optional
nickel-plated version
optional full stainless
steel version

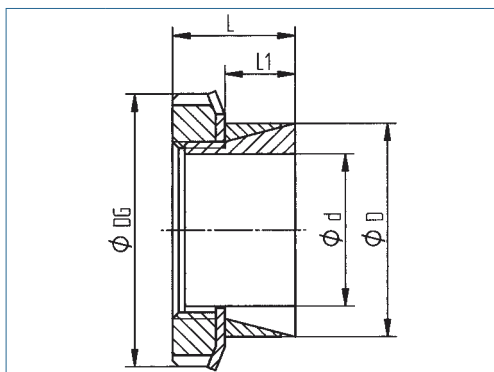

transmittable torque	low
surface pressure on hub	low
self-centering	no
axial movement of the hub during assembly	no
height D/d	flat
overall length	short

Order Code

KBS 51 - 20 x 30

Type

ϕd

ϕD

Recommended finishing tolerances of contact surfaces are: shaft h8 / hub H8

Inner / Outer dxD	Torque T Nm	Dimensions			Surface pressure on		Nut		Mass kg
		DG mm	L mm	L1 mm	Shaft Pw N/mm ²	Hub Pn N/mm ²	Size	TA Nm	
14 x 25	52	32	17	6.5	217	68	M20x1	95	0.05
15 x 25	56	32	17	6.5	203	73	M20x1	95	0.05
16 x 25	60	32	17	6.5	191	78	M20x1	95	0.04
17 x 25	65	32	17	6.5	184	85	M20x1	95	0.04
18 x 30	91	38	17.5	6.5	229	83	M25x1.5	160	0.08
19 x 30	96	38	18	6.5	217	87	M25x1.5	160	0.08
20 x 30	102	38	18	6.5	139	93	M25x1.5	160	0.08
22 x 35	115	45	18	6.5	194	77	M30x1.5	220	0.11
24 x 35	139	45	18	6.5	197	93	M30x1.5	220	0.09
25 x 35	144	45	18	6.5	188	96	M30x1.5	220	0.10
28 x 40	215	52	18	6.5	224	110	M35x1.5	340	0.12
30 x 40	230	52	20	8	169	95	M35x1.5	340	0.13
32 x 45	315	58	22	8	204	103	M40x1.5	480	0.19
35 x 45	331	58	22	8	179	108	M40x1.5	480	0.17
36 x 45	340	58	22	8	174	111	M40x1.5	480	0.17
38 x 50	450	65	25	10	165	95	M45x1.5	680	0.23
40 x 50	477	65	25	10	158	101	M45x1.5	680	0.24
42 x 55	580	70	26	10	174	102	M50x1.5	870	0.30
45 x 55	617	70	26	10	162	108	M50x1.5	870	0.28
48 x 60	669	75	26	10	154	99	M55x2	970	0.33
50 x 60	697	75	26	10	148	103	M55x2	970	0.35
55 x 65	796	80	27	12	116	83	M60x2	1100	0.36
56 x 68	620	80	27.5	12	87	59	M60x2	1100	0.34
60 x 70	946	85	29	12	116	85	M65x2	1300	0.42
63 x 79	890	92	30.5	13.5	88	56	M70x2	1300	0.56
65 x 79	920	92	30.5	13.5	86	58	M70x2	1300	0.52
70 x 84	1433	98	31.5	13.5	115	810	M75x2	2000	0.52