

Miniature Metal Bellows Coupling

with stainless steel collet clamps

optional
laserwelded

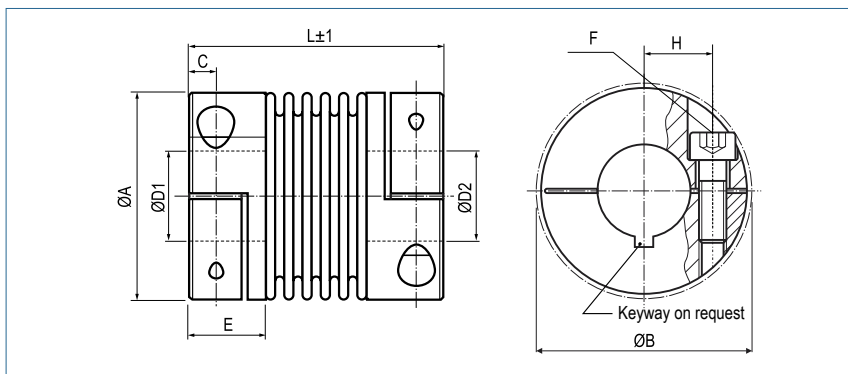

Order Code

KB2 / 45 - 50 - 10 - 16 - VA/VAW

Type / Size

Length
L

ØD1
(H7)

ØD2
(H7)

stainless steel
glued / laserwelded

Size	Torque TKN (Nm)	Dimensions (mm)								Technical Data							
		L	Ø A	D1/D2	H	C	Ø B	E	F	Mass (g)	Moment of Inertia J (g cm ²)	Spring Stiffness			Misalignment		
		Length	Outer Ø	Bore Sizes (H7) min-max			Hub- length	Screw (ISO4762) TA (Nm)	torsional CT (Nm/rad)			radial CR (N/mm)	axial CA (N/mm)	radial ΔKr (mm)	axial ΔKa (mm)	angular ΔKw (°)	
1	0.1	25	10	1-4	3.4	2	11	7	M1.6 0.1	7	1	65	10	14	0.12	0.2	1.2
5	0.5	21	15.5	3-8	5.2	2.5	17.5	7	M2	18	5.9	260	43	13	0.1	0.2	1
		25		8#					18	6.2	200	18	10	0.15	0.3	1.5	
		28							19	6.6	160	9	8	0.2	0.4	2	
10	1	23	15.5	3-8	5.2	2.5	17.5	7	M2	19	6.8	510	74	27	0.1	0.2	1
		26		8#					20	7.5	380	31	20	0.15	0.3	1.5	
		31							21	8.1	310	16	16	0.2	0.4	2	
15	1.5	26	20	3-10	7	3	21	8,5	M2.5	36	18	750	59	15	0.1	0.3	1.5
		31		10#					38	21	700	20	9	0.15	0.4	2	
20	2	32	25	3-14	9	3.5	27	11	M3	70	53	1500	67	12	0.15	0.3	1.5
		38		14#					73	60	1300	21	11	0.2	0.4	1.5	
		42							75	64	1050	11	9	0.25	0.5	2	
45	4.5	41	32.5	6-18	11.5	5	34	13	M4	133	220	6500	168	32	0.1	0.3	1.5
		50		18#					139	246	4200	41	20	0.2	0.5	2	
100	10	47	40.5	6-25	15.5	5	41.5	13,5	M4	244	513	8100	120	27	0.15	0.4	1.5
		57		25#					261	638	6800	29	17	0.3	0.6	2	



Speed	max. 15000 min ⁻¹
Material	bellows - stainless steel hub - stainless Steel
Hub	bore tolerance: H7
Temperature Range	VA -30 °C ~ 120 °C (glued) VAW -30 °C ~ 250 °C (laserwelded)
Keyway	optional acc. DIN 6885 biggest bore marked with a #