



SHAFT HUB CONNECTIONS

LOCKING DEVICES
SHRINK DISCS
LOCKING ELEMENTS
RIGID SHAFT COUPLINGS

KBK – The Company

KBK Antriebstechnik GmbH - successful since 2003

Our products are based on the experience of more than 30 years in developing and producing shaft-hub-connections and backlash-free couplings combined with professional advice, service and professional competence. Our sophisticated modular design forms the basis for top quality products at reasonable prices. It enables us to produce almost all elastomer-, metal bellows-, safety couplings and line shafts as well as locking devices from the standard range within two hours, provide them with customized bores and organize a direct delivery to you by courier. Our traffic-favourable position on the edge of the Rhine-Main area simplifies the delivery to our customers all over the world. Benefit from our strenghts and our strong motivation to satisfy all our business-partners and safe time and money for your company.

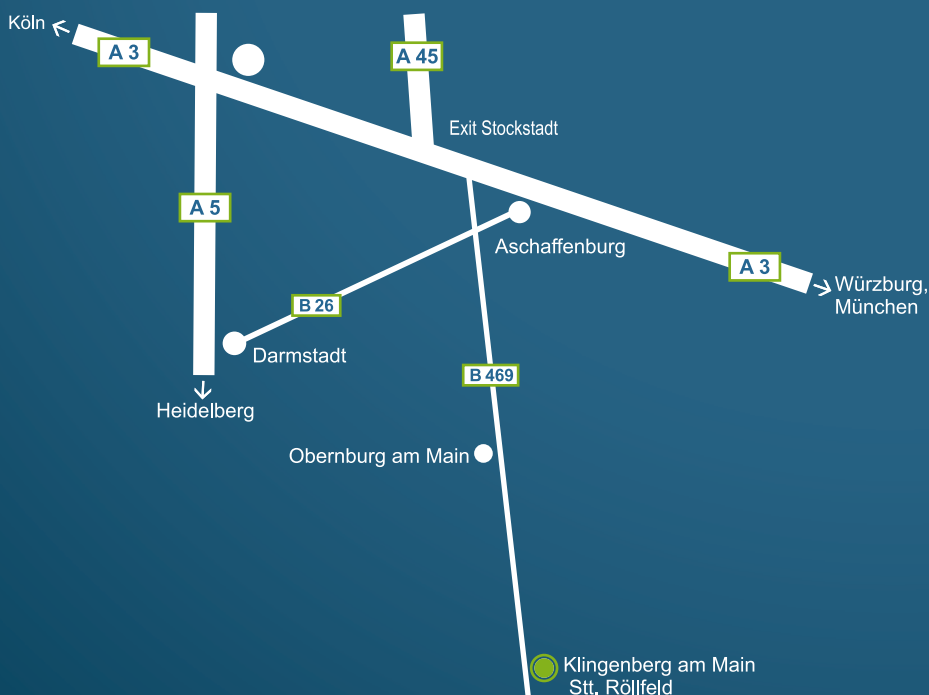

Contents

**Hub dimensioning for the use
of KBK locking devices**

Page 4 - 6

Locking Devices

Page 7 / 8

KBS 10

Page 9

KBS 11

Page 10

KBS 13

Page 11

KBS 15

Page 12

KBS 16

Page 13

KBS 18

Page 14

KBS 40

Page 15

KBS 51

Page 16

KBS 52

Page 17

KBS 55

Page 18

KBS 56

Page 19

KBS 57

Page 20

KBS 58

Page 21

KBS 59

Page 22

KBS 61

Page 23

KBS 62

Page 24

KBS 70

Page 25

KBS 71

Page 26

KBS 80

Page 27

**Shrink Discs, Locking Elements and
Rigid Shaft Couplings**

Page 28

KBS 19

Page 29 - 31

KBS19/1

Page 32

KBS 50

Page 33 / 34

KBS 95

Page 35

Hub dimensioning for the use of KBK locking devices

Preliminary design of the hub

The hub material is stressed by the surface pressure on the hub (see also information in the technical data sheets). To prevent a slight separation / destruction of the hub by the locking device, the minimum outer diameter of the hub should be taken into consideration for the dimensioning. This depends on the material, mounting conditions and the surface pressure generated by the locking device.

When choosing the material it has to be ensured, that the surface pressure of the locking device on the hub must not exceed the yield strength $R_{p0.2}$ of the hub material.

The following tables show multipliers (K) depending on the yield strength and the mounting conditions, by which the minimum outer diameter of the hub can be roughly determined.

This rule applies: $DN = D \times K$

(D = outer diameter of the locking device; K = installation factor)

$$B \geq L1 : X = 1$$

$$B \geq 2 \times L1 : X = 0,8$$

$$B > 2 \times L1 : X = 0,6$$

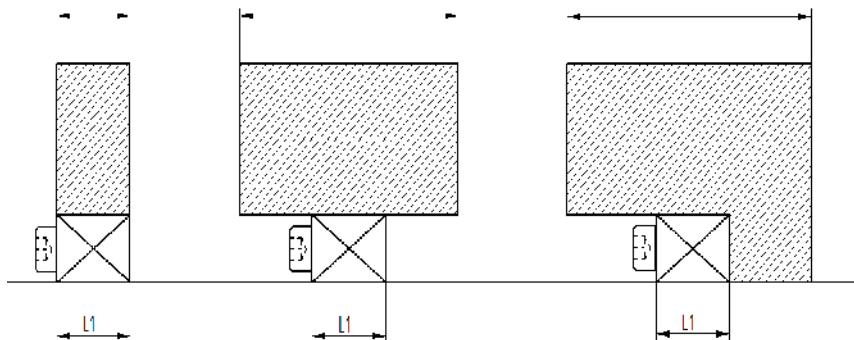

Surface Pressure [N/mm ²]	Stress Reduction Factor X	Yield strength of the hub material (N/mm ²)										
		150	180	200	220	250	270	300	350	400	450	600
		GJL-200		GJL-250	GJL-300	GJS-400		GJS-500	GJS-600	GJS-700	GJS-800	
					S235	11SMn30	S275		S355		C45E	16MnCr5
		1.4301	1.4401		AW 2011					AW 7075		
60	0,6	1,28	1,22	1,20	1,18	1,16	1,14	1,13	1,11	1,09	1,08	1,06
60	0,8	1,39	1,31	1,28	1,25	1,21	1,20	1,18	1,15	1,13	1,11	1,08
60	1	1,53	1,41	1,36	1,32	1,28	1,25	1,22	1,19	1,16	1,14	1,11
65	0,6	1,30	1,25	1,22	1,20	1,17	1,16	1,14	1,12	1,10	1,09	1,07
65	0,8	1,44	1,35	1,30	1,27	1,24	1,22	1,19	1,16	1,14	1,12	1,09
65	1	1,59	1,46	1,40	1,36	1,30	1,28	1,25	1,21	1,18	1,16	1,11
70	0,6	1,33	1,27	1,24	1,21	1,18	1,17	1,15	1,13	1,11	1,10	1,07
70	0,8	1,48	1,38	1,33	1,30	1,26	1,23	1,21	1,18	1,15	1,13	1,10
70	1	1,66	1,51	1,44	1,39	1,33	1,30	1,27	1,22	1,19	1,17	1,12
75	0,6	1,36	1,29	1,26	1,23	1,20	1,18	1,16	1,14	1,12	1,11	1,08
75	0,8	1,53	1,41	1,36	1,32	1,28	1,25	1,22	1,19	1,16	1,14	1,11
75	1	1,73	1,56	1,48	1,43	1,36	1,33	1,29	1,24	1,21	1,18	1,13
80	0,6	1,39	1,31	1,28	1,25	1,21	1,20	1,18	1,15	1,13	1,11	1,08
80	0,8	1,58	1,45	1,39	1,35	1,30	1,27	1,24	1,20	1,18	1,15	1,11
80	1	1,81	1,61	1,53	1,46	1,39	1,36	1,31	1,26	1,22	1,20	1,14
90	0,6	1,46	1,36	1,32	1,28	1,25	1,22	1,20	1,17	1,15	1,13	1,09
90	0,8	1,69	1,53	1,46	1,40	1,34	1,31	1,28	1,23	1,20	1,18	1,13
90	1	2,00	1,73	1,62	1,54	1,46	1,41	1,36	1,30	1,26	1,22	1,16
95	0,6	1,49	1,39	1,34	1,30	1,26	1,24	1,21	1,18	1,15	1,14	1,10
95	0,8	1,75	1,57	1,49	1,43	1,37	1,34	1,30	1,25	1,21	1,19	1,14
95	1	2,11	1,80	1,68	1,59	1,49	1,44	1,39	1,32	1,27	1,24	1,17
100	0,6	1,53	1,41	1,36	1,32	1,28	1,25	1,22	1,19	1,16	1,14	1,11
100	0,8	1,81	1,61	1,53	1,46	1,39	1,36	1,31	1,26	1,22	1,20	1,14
100	1	2,24	1,87	1,73	1,63	1,53	1,48	1,41	1,34	1,29	1,25	1,18
105	0,6	1,56	1,44	1,39	1,34	1,29	1,27	1,24	1,20	1,17	1,15	1,11
105	0,8	1,88	1,66	1,56	1,50	1,42	1,38	1,33	1,28	1,24	1,21	1,15
105	1	2,38	1,95	1,79	1,68	1,56	1,51	1,44	1,36	1,31	1,27	1,19
110	0,6	1,60	1,47	1,41	1,36	1,31	1,28	1,25	1,21	1,18	1,16	1,12
110	0,8	1,96	1,71	1,60	1,53	1,44	1,40	1,35	1,29	1,25	1,22	1,16
110	1	2,55	2,04	1,86	1,73	1,60	1,54	1,47	1,38	1,33	1,28	1,20
115	0,6	1,64	1,50	1,43	1,38	1,33	1,30	1,26	1,22	1,19	1,17	1,12
115	0,8	2,04	1,76	1,64	1,56	1,47	1,43	1,37	1,31	1,26	1,23	1,17
115	1	2,75	2,13	1,93	1,79	1,64	1,58	1,50	1,41	1,34	1,30	1,21
120	0,6	1,69	1,53	1,46	1,40	1,34	1,31	1,28	1,23	1,20	1,18	1,13
120	0,8	2,13	1,81	1,69	1,60	1,50	1,45	1,39	1,33	1,28	1,24	1,18
120	1	3,00	2,24	2,00	1,84	1,69	1,61	1,53	1,43	1,36	1,31	1,22
125	0,6	1,73	1,56	1,48	1,43	1,36	1,33	1,29	1,24	1,21	1,18	1,13
125	0,8	2,24	1,87	1,73	1,63	1,53	1,48	1,41	1,34	1,29	1,25	1,18
125	1	3,32	2,35	2,08	1,91	1,73	1,65	1,56	1,45	1,38	1,33	1,24
130	0,6	1,78	1,59	1,51	1,45	1,38	1,35	1,30	1,25	1,22	1,19	1,14
130	0,8	2,35	1,93	1,78	1,67	1,56	1,50	1,44	1,36	1,30	1,27	1,19
130	1	3,74	2,49	2,17	1,97	1,78	1,69	1,59	1,48	1,40	1,35	1,25
135	0,6	1,83	1,62	1,54	1,47	1,40	1,36	1,32	1,27	1,23	1,20	1,15
135	0,8	2,48	2,00	1,83	1,71	1,59	1,53	1,46	1,38	1,32	1,28	1,20
135	1	4,36	2,65	2,27	2,04	1,83	1,73	1,62	1,50	1,42	1,36	1,26



The values as shown in the table are only a basis for the rough dimensioning of the outer diameter of the hub and are no warranty for the correct functioning.
In case of any doubt, please contact our technical experts!

Surface Pressure [N/mm ²]	Stress Reduction Factor X	Yield strength of the hub material (N/mm ²)										
		150	180	200	220	250	270	300	350	400	450	600
		GJL-200		GJL-250	GJL-300	GJS-400		GJS-500	GJS-600	GJS-700	GJS-800	
					S235	11SMn30	S275		S355		C45E	16MnCr5
		1.4301	1.4401		AW 2011					AW 7075		
140	0,6	1,88	1,66	1,56	1,50	1,42	1,38	1,33	1,28	1,24	1,21	1,15
140	0,8	2,63	2,07	1,88	1,75	1,62	1,55	1,48	1,39	1,33	1,29	1,21
140	1	5,39	2,83	2,38	2,12	1,88	1,78	1,66	1,53	1,44	1,38	1,27
145	0,6	1,94	1,69	1,59	1,52	1,44	1,40	1,35	1,29	1,25	1,22	1,16
145	0,8	2,80	2,15	1,94	1,80	1,65	1,58	1,50	1,41	1,35	1,30	1,22
145	1	7,68	3,05	2,50	2,21	1,94	1,82	1,69	1,55	1,46	1,40	1,28
150	0,6	2,00	1,73	1,62	1,54	1,46	1,41	1,36	1,30	1,26	1,22	1,16
150	0,8	3,00	2,24	2,00	1,84	1,69	1,61	1,53	1,43	1,36	1,31	1,22
150	1	-	3,32	2,65	2,30	2,00	1,87	1,73	1,58	1,48	1,41	1,29
155	0,6	2,06	1,77	1,65	1,57	1,48	1,43	1,38	1,31	1,27	1,23	1,17
155	0,8	3,25	2,33	2,06	1,89	1,72	1,64	1,55	1,45	1,38	1,33	1,23
155	1	-	3,66	2,81	2,40	2,06	1,92	1,77	1,61	1,51	1,43	1,30
160	0,6	2,13	1,81	1,69	1,60	1,50	1,45	1,39	1,33	1,28	1,24	1,18
160	0,8	3,55	2,43	2,13	1,94	1,76	1,67	1,58	1,47	1,39	1,34	1,24
160	1	-	4,12	3,00	2,52	2,13	1,98	1,81	1,64	1,53	1,45	1,31
165	0,6	2,21	1,86	1,72	1,62	1,52	1,47	1,41	1,34	1,29	1,25	1,18
165	0,8	3,96	2,55	2,21	2,00	1,80	1,71	1,60	1,49	1,41	1,35	1,25
165	1	-	4,80	3,23	2,65	2,21	2,04	1,86	1,67	1,55	1,47	1,33
170	0,6	2,29	1,90	1,76	1,65	1,54	1,49	1,42	1,35	1,30	1,26	1,19
170	0,8	4,52	2,68	2,29	2,06	1,84	1,74	1,63	1,51	1,42	1,37	1,26
170	1	-	5,92	3,51	2,79	2,29	2,10	1,90	1,70	1,57	1,49	1,34
175	0,6	2,38	1,95	1,79	1,68	1,56	1,51	1,44	1,36	1,31	1,27	1,19
175	0,8	5,39	2,83	2,38	2,12	1,88	1,78	1,66	1,53	1,44	1,38	1,27
175	1	-	8,43	3,87	2,96	2,38	2,16	1,95	1,73	1,60	1,51	1,35
180	0,6	2,48	2,00	1,83	1,71	1,59	1,53	1,46	1,38	1,32	1,28	1,20
180	0,8	7,00	3,00	2,48	2,19	1,93	1,81	1,69	1,55	1,46	1,39	1,28
180	1	-	-	4,36	3,16	2,48	2,24	2,00	1,77	1,62	1,53	1,36
185	0,6	2,59	2,05	1,87	1,74	1,61	1,55	1,47	1,39	1,33	1,29	1,21
185	0,8	12,21	3,20	2,59	2,26	1,98	1,85	1,72	1,57	1,47	1,41	1,29
185	1	-	-	5,07	3,40	2,59	2,31	2,05	1,80	1,65	1,55	1,38
190	0,6	2,71	2,11	1,91	1,78	1,64	1,57	1,49	1,40	1,34	1,30	1,21
190	0,8	-	3,44	2,71	2,34	2,03	1,89	1,75	1,59	1,49	1,42	1,30
190	1	-	-	6,24	3,70	2,71	2,40	2,11	1,84	1,68	1,57	1,39
195	0,6	2,84	2,17	1,95	1,81	1,66	1,59	1,51	1,42	1,35	1,30	1,22
195	0,8	-	3,74	2,84	2,42	2,08	1,93	1,78	1,62	1,51	1,44	1,30
195	1	-	-	8,89	4,07	2,84	2,49	2,17	1,88	1,70	1,59	1,40
200	0,6	3,00	2,24	2,00	1,84	1,69	1,61	1,53	1,43	1,36	1,31	1,22
200	0,8	-	4,12	3,00	2,52	2,13	1,98	1,81	1,64	1,53	1,45	1,31
200	1	-	-	-	4,58	3,00	2,59	2,24	1,91	1,73	1,61	1,41



The values as shown in the table are only a basis for the rough dimensioning of the outer diameter of the hub and are no warranty for the correct functioning. In case of any doubt, please contact our technical experts!

LOCKING DEVICES

KBS 10

Locking Device



P. 9

KBS 11

Locking Device



P. 10

KBS 13

Locking Device



P. 11

KBS 15

Locking Device



P. 12

KBS 16

Locking Device



P. 13

KBS 18

Locking Device



P. 14

KBS 40

Locking Device



P. 15

KBS 51

Locking Device



P. 16

KBS 52

Locking Device



P. 17

KBS 55

Locking Device



P. 18

KBS 56

Locking Device



P. 19

KBS 57

Locking Device



P. 20

LOCKING DEVICES

KBS 58

Locking Device



P. 21

KBS 59

Locking Device



P. 22

KBS 61

Locking Device



P. 23

KBS 62

Locking Device



P. 24

KBS 70

Locking Device



P. 25

KBS 71

Locking Device



P. 26

KBS 80

Locking Device



P. 27

Locking Device

optional
nickel-plated version
optional full stainless
steel version

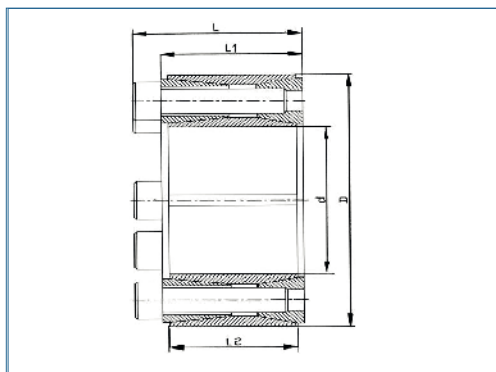

transmittable torque	high
surface pressure on hub	medium
self-centering	yes
axial movement of the hub during assembly	none
height D/d	high
overall length	long

Order Code

KBS 10 - 45 x 85

Type

Ød

ØD

Recommended finishing tolerances of contact surfaces are: shaft h8 / hub H8

Inner / Outer Ø dxD	Torque T Nm	Dimensions			Surface pressure on		Screws			Mass kg
		L mm	L 1 mm	L 2 mm	Shaft Pw N/mm²	Hub Pn N/mm²	No.	ISO 4762	TA Nm	
45 x 85	3140	60	50	44	278	148	8	M10x45	84	1.4
50 x 90	3470	60	50	44	253	141	8	M10x45	84	1.5
55 x 95	3800	60	50	44	223	130	8	M10x45	84	1.6
60 x 100	4130	60	50	44	208	125	8	M10x45	84	1.7
65 x 115	6520	74	62	56	230	130	8	M12x55	145	3.1
70 x 120	7000	74	62	56	205	120	8	M12x55	145	3.3
80 x 130	11900	74	62	56	269	165	12	M12x55	145	3.7
90 x 140	13300	74	62	56	240	154	12	M12x55	145	4.0
100 x 160	20100	94	80	74	217	136	12	M14x70	235	7.2
110 x 170	25400	94	80	74	231	154	14	M14x70	235	7.7
120 x 180	29600	94	80	74	227	151	15	M14x70	235	8.3
130 x 190	34000	94	80	74	223	153	16	M14x70	235	8.8
140 x 200	38800	94	80	74	219	153	17	M14x70	235	9.3
150 x 210	43900	94	80	74	217	155	18	M14x70	235	10.0
160 x 230	61400	110	94	88	218	152	17	M16x80	365	14.9
170 x 240	68900	110	94	88	217	154	18	M16x80	365	15.7
180 x 250	80300	110	94	88	227	164	20	M16x80	365	16.4
190 x 260	89500	110	94	88	227	166	21	M16x80	365	17.2
200 x 270	102000	110	94	88	235	174	23	M16x80	365	18.8
220 x 300	126000	134	116	110	194	142	21	M18x100	500	27.7
240 x 320	157000	134	116	110	203	152	24	M18x100	500	29.8
260 x 340	184000	134	116	110	203	155	26	M18x100	500	32.0
280 x 370	236000	156	136	130	197	149	24	M20x120	710	46.0
300 x 390	249000	156	136	130	182	140	24	M20x120	710	49.0

Locking Device

optional
nickel-plated version
optional full stainless
steel version

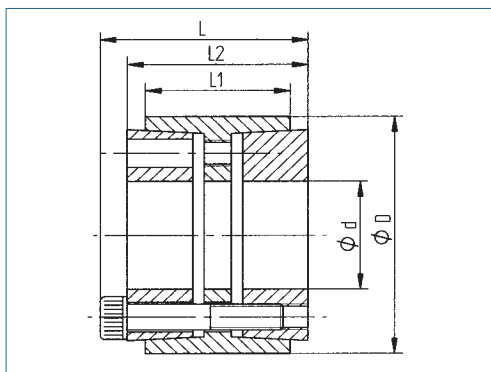

transmittable torque	high
surface pressure on hub	medium
self-centering	yes
axial movement of the hub during assembly	conditionally
height D/d	high
overall length	long

Order Code

KBS 11 - 45 x 75

Type Ød ØD

Recommended finishing tolerances of contact surfaces are: shaft h8 / hub H8

Inner / Outer Ø dxD	Torque T Nm	Dimensions			Surface pressure on		Screws			Mass kg
		L mm	L1 mm	L2 mm	Shaft Pw N/mm²	Hub Pn N/mm²	No.	ISO 4762	TA Nm	
25 x 55	840	46	32	40	295	134	6	M6x35	17	0.37
28 x 55	940	46	32	40	264	134	6	M6x35	17	0.38
30 x 55	1000	46	32	40	246	134	6	M6x35	17	0.40
35 x 60	1360	60	44	54	174	101	7	M6x45	17	0.60
38 x 75	2740	62	44	54	296	150	7	M8x50	41	1.05
40 x 75	2880	62	44	54	281	150	7	M8x50	41	1.05
42 x 75	3030	62	44	54	268	150	7	M8x50	41	1.10
45 x 75	3240	62	44	54	250	150	7	M8x50	41	1.10
48 x 80	3950	72	56	64	207	124	8	M8x50	41	1.15
50 x 80	4150	72	56	64	200	98	8	M8x50	41	1.15
55 x 85	5150	72	56	64	205	104	9	M8x50	41	1.30
60 x 90	6200	72	56	64	202	106	10	M8x50	41	1.35
65 x 95	6750	72	56	64	187	100	10	M8x50	41	1.45
70 x 110	11500	88	70	78	223	114	10	M10x60	83	2.75
75 x 115	12300	88	70	78	223	114	10	M10x60	83	3.00
80 x 120	14500	88	70	78	215	115	11	M10x60	83	3.15
85 x 125	15400	88	70	78	215	115	12	M10x60	83	3.25
90 x 130	17800	88	70	78	208	115	12	M10x60	83	3.50
95 x 135	18700	88	70	78	208	115	12	M10x60	83	4.80
100 x 145	26300	112	90	100	200	107	11	M12x80	145	5.70
110 x 155	31800	112	90	100	198	110	12	M12x80	145	6.10
120 x 165	40400	112	90	100	212	120	14	M12x80	145	6.60
130 x 180	51500	130	104	116	192	112	12	M14x90	230	9.18
140 x 190	64700	130	104	116	208	124	14	M14x90	230	9.80
150 x 200	74200	130	104	116	208	127	15	M14x90	230	10.40
160 x 210	84500	130	104	116	208	128	16	M14x90	230	10.90
170 x 225	108200	164	134	148	182	113	14	M16x110	355	16.20
180 x 235	123250	164	134	148	184	115	15	M16x110	355	16.85
190 x 250	133800	164	134	148	186	116	16	M16x110	355	19.67
200 x 260	146000	164	134	148	177	112	16	M16x110	355	20.57
220 x 285	181000	164	134	148	188	115	18	M16x110	355	24.46
240 x 305	218000	164	134	148	184	119	20	M16x110	355	26.40
260 x 325	250000	164	134	148	178	117	21	M16x110	355	28.73
280 x 355	360000	197	165	177	185	117	18	M20x130	690	43.0
300 x 375	428000	197	165	177	192	123	20	M20x130	690	46.5

Locking Device

optional
nickel-plated version
optional full stainless
steel version

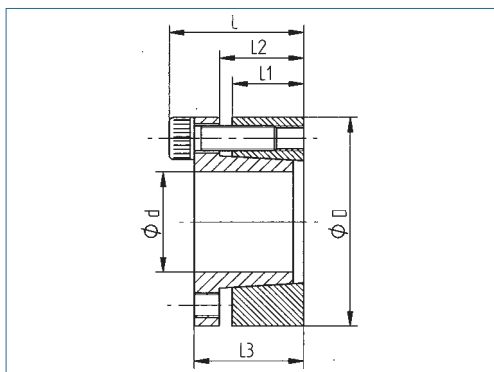

transmittable torque	medium
surface pressure on hub	medium
self-centering	yes
axial movement of the hub during assembly	yes
height D/d	high
overall length	short

Order Code

KBS 13 - 30 x 55

Type

Ød

ØD

Recommended finishing tolerances of contact surfaces are: shaft h8 / hub H8

Inner / Outer Ø dxD	Torque T Nm	Dimensions				Surface pressure on		Screws			Mass kg
		L mm	L1 mm	L2 mm	L3 mm	Shaft Pw N/mm ²	Hub Pn N/mm ²	No.	ISO 4762	TA Nm	
18 x 47	310	34	17	22	28	314	120	5	M6x20	14	0.26
19 x 47	330	34	17	22	28	300	120	5	M6x20	14	0.25
20 x 47	380	34	17	22	28	295	125	5	M6x20	14	0.25
22 x 47	410	34	17	22	28	270	125	5	M6x20	14	0.25
24 x 50	440	34	17	22	28	243	120	6	M6x20	14	0.26
25 x 50	560	34	17	22	28	285	140	6	M6x20	14	0.26
28 x 55	630	34	17	22	28	255	130	6	M6x20	14	0.29
30 x 55	660	34	17	22	28	235	130	6	M6x20	14	0.30
32 x 60	960	34	17	22	28	295	155	8	M6x20	14	0.33
35 x 60	1050	34	17	22	28	270	155	8	M6x20	14	0.34
38 x 65	1140	34	17	22	28	250	145	8	M6x20	14	0.35
40 x 65	1200	34	17	22	28	235	145	8	M6x20	14	0.35
42 x 75	2040	41	20	25	33	310	170	7	M8x25	35	0.60
45 x 75	2180	41	20	25	33	290	170	7	M8x25	35	0.60
48 x 80	2300	41	20	25	33	280	180	7	M8x25	35	0.65
50 x 80	2430	41	20	25	33	260	160	7	M8x25	35	0.65
55 x 85	3070	41	20	25	33	270	175	8	M8x25	35	0.70
60 x 90	3350	41	20	25	33	245	165	8	M8x25	35	0.75
65 x 95	4080	41	20	25	33	255	175	9	M8x25	35	0.80
70 x 110	6280	50	24	30	40	280	180	8	M10x30	70	1.55
75 x 115	6680	50	24	30	40	260	170	8	M10x30	70	1.65
80 x 120	7130	50	24	30	40	250	160	8	M10x30	70	1.70
85 x 125	8480	50	24	30	40	260	180	9	M10x30	70	1.85
90 x 130	9080	50	24	30	40	250	170	9	M10x30	70	1.90
95 x 135	10580	50	24	30	40	260	180	10	M10x30	70	2.00
100 x 145	13380	56	26	32	44	270	190	8	M12x35	125	2.65
110 x 155	14580	56	26	32	44	240	180	8	M12x35	125	2.83
120 x 165	17880	56	26	32	44	250	180	9	M12x35	125	3.10
130 x 180	29980	64	34	40	52	240	170	12	M12x35	125	4.60
140 x 190	26980	68	34	40	54	210	150	9	M14x40	190	4.92
150 x 200	32980	68	34	40	54	230	170	10	M14x40	190	5.10
160 x 210	37980	68	34	40	54	230	170	11	M14x40	190	5.45
170 x 225	44980	78	44	50	64	180	130	12	M14x40	190	7.70
180 x 235	46980	78	44	50	64	170	130	12	M14x40	190	8.00

Locking Device

optional
nickel-plated version
optional full stainless
steel version



KBK

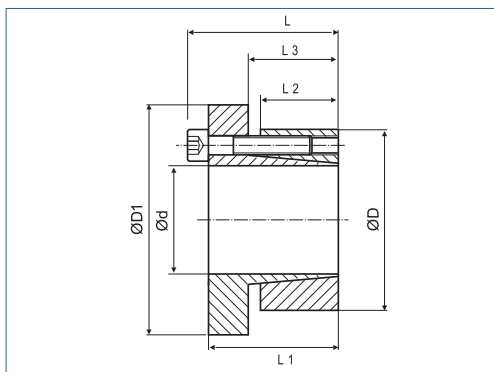

transmittable Torque	medium
surface pressure on hub	medium
self-centering	yes
axial movement of the hub during assembly	no
height D/d	high
overall length	short

Order Code

KBS 15 - 20 x 55

Type

Ød

ØD

Recommended finishing tolerances of contact surfaces are: shaft h8 / hub H8

Inner / Outer Ø dxD	Torque T Nm	Dimensions					Surface pressure on		Screws			Mass kg
		D1 mm	L mm	L1 mm	L2 mm	L3 mm	Shaft Pw N/mm ²	Hub Pn N/mm ²	No.	ISO 4762	TA Nm	
14 x 55	290	62	39	31	17	22	460	110	4	M8x25	42	0.50
16 x 55	360	62	39	31	17	22	400	110	4	M8x25	42	0.50
18 x 55	370	62	39	31	17	22	360	110	4	M8x25	42	0.50
19 x 55	390	62	39	31	17	22	340	110	4	M8x25	42	0.50
20 x 55	410	62	39	31	17	22	320	110	4	M8x25	42	0.50
22 x 55	450	62	39	31	17	22	290	110	4	M8x25	42	0.45
24 x 55	490	62	39	31	17	22	270	110	4	M8x25	42	0.45
25 x 55	510	62	39	31	17	22	260	110	4	M8x25	42	0.45
28 x 55	570	62	39	31	17	22	230	110	4	M8x25	42	0.45
30 x 55	610	62	39	31	17	22	220	110	4	M8x25	42	0.60
24 x 65	610	72	39	31	17	22	330	120	5	M8x25	42	0.65
25 x 65	640	72	39	31	17	22	320	120	5	M8x25	42	0.40
28 x 65	710	72	39	31	17	22	290	120	5	M8x25	42	0.60
30 x 65	770	72	39	31	17	22	270	120	5	M8x25	42	0.60
32 x 65	820	72	39	31	17	22	250	120	5	M8x25	42	0.60
33 x 65	850	72	39	31	17	22	240	120	5	M8x25	42	0.60
35 x 65	890	72	39	31	17	22	230	120	5	M8x25	42	0.60
38 x 65	970	72	39	31	17	22	210	120	5	M8x25	42	0.50
40 x 65	1020	72	39	31	17	22	200	120	5	M8x25	42	0.50
30 x 80	1070	87	41	33	20	25	320	110	7	M8x25	42	0.95
32 x 80	1140	87	41	33	20	25	300	110	7	M8x25	42	1.00
33 x 80	1180	87	41	33	20	25	280	110	7	M8x25	42	1.00
35 x 80	1250	87	41	33	20	25	270	110	7	M8x25	42	1.10
38 x 80	1350	87	41	33	20	25	250	110	7	M8x25	42	1.00
40 x 80	1420	87	41	33	20	25	240	110	7	M8x25	42	1.00
42 x 80	1500	87	41	33	20	25	230	110	7	M8x25	42	0.90
45 x 80	1600	87	41	33	20	25	210	110	7	M8x25	42	0.88
48 x 80	1710	87	41	33	20	25	200	110	7	M8x25	42	0.80
50 x 80	1780	87	41	33	20	25	190	110	7	M8x25	42	1.00

Locking Device

optional
nickel-plated version
optional full stainless
steel version

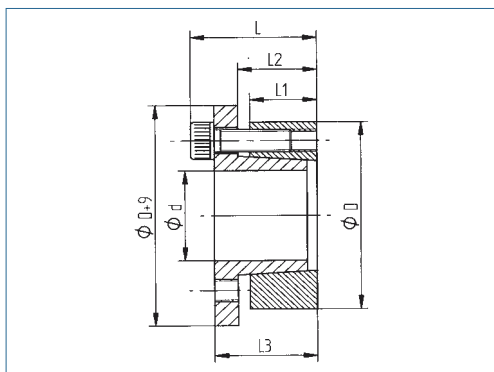

transmittable torque	medium
surface pressure on hub	medium
self-centering	yes
axial movement of the hub during assembly	no
height D/d	high
overall length	short

Order Code

KBS 16 - 75 x 115

Type Ød ØD

Recommended finishing tolerances of contact surfaces are: shaft h8 / hub H8

Inner / Outer Ø dxD	Torque T Nm	Dimensions				Surface pressure on		Screws			Mass kg
		L mm	L1 mm	L2 mm	L3 mm	Shaft Pw N/mm ²	Hub Pn N/mm ²	No.	ISO 4762	TA Nm	
18 x 47	260	34	17	22	28	240	93	5	M6x20	17	0.28
19 x 47	270	34	17	22	28	230	93	5	M6x20	17	0.28
20 x 47	280	34	17	22	28	220	95	5	M6x20	17	0.28
22 x 47	300	34	17	22	28	200	95	5	M6x20	17	0.29
24 x 50	400	34	17	22	28	215	107	6	M6x20	17	0.30
25 x 50	420	34	17	22	28	210	105	6	M6x20	17	0.30
28 x 55	470	34	17	22	28	190	96	6	M6x20	17	0.33
30 x 55	500	34	17	22	28	180	95	6	M6x20	17	0.36
32 x 60	720	34	17	22	28	220	115	8	M6x20	17	0.40
35 x 60	790	34	17	22	28	200	115	8	M6x20	17	0.41
38 x 65	850	34	17	22	28	185	105	8	M6x20	17	0.42
40 x 65	900	34	17	22	28	175	105	8	M6x20	17	0.45
42 x 75	1520	41	20	25	33	230	125	7	M8x25	41	0.70
45 x 75	1620	41	20	25	33	215	125	7	M8x25	41	0.70
48 x 80	1720	41	20	25	33	210	120	7	M8x25	41	0.75
50 x 80	1820	41	20	25	33	195	120	7	M8x25	41	0.75
55 x 85	2300	41	20	25	33	200	130	8	M8x25	41	0.80
60 x 90	2500	41	20	25	33	185	125	8	M8x25	41	0.90
65 x 95	3050	41	20	25	33	190	130	9	M8x25	41	0.95
70 x 110	4660	50	24	30	40	210	135	8	M10x30	83	1.75
75 x 115	5000	50	24	30	40	195	125	8	M10x30	83	1.80
80 x 120	5300	50	24	30	40	185	125	8	M10x30	83	1.90
85 x 125	6350	50	24	30	40	195	135	9	M10x30	83	1.95
90 x 130	6760	50	24	30	40	185	130	9	M10x30	83	2.10
95 x 135	7900	50	24	30	40	195	135	10	M10x30	83	2.15
100 x 145	9700	56	26	32	44	200	140	8	M12x35	145	2.85
110 x 155	10600	56	26	32	44	180	130	8	M12x35	145	3.10
120 x 165	13000	56	26	32	44	185	135	9	M12x35	145	3.35
130 x 180	18900	64	34	40	52	175	125	12	M12x35	145	4.70
140 x 190	20600	68	34	40	54	165	120	9	M14x40	230	5.35
150 x 200	25100	68	34	40	54	175	130	10	M14x40	230	5.65
160 x 210	29100	68	34	40	54	180	135	11	M14x40	230	5.85
170 x 225	34100	78	44	50	64	140	105	12	M14x40	230	8.25
180 x 235	36100	78	44	50	64	135	105	12	M14x40	230	8.60

Locking Device

optional
nickel-plated version
optional full stainless
steel version

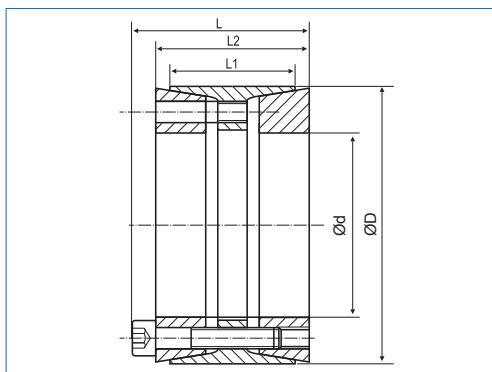

transmittable torque	high
surface pressure on hub	medium
self-centering	yes
axial movement of the hub during assembly	conditionally
height D/d	high
overall length	medium

Order Code

KBS 18 - 130 x 180

Type Ød ØD

Recommended finishing tolerances of contact surfaces are: shaft h8 / hub H8

Inner / Outer Ø dxD	Torque T Nm	Dimensions			Surface pressure on		Screws			Mass kg
		L mm	L1 mm	L2 mm	Shaft Pw N/mm²	Hub Pn N/mm²	No.	ISO 4762	TA Nm	
70 x 110	7300	72	50	62	197	125	8	M10	83	2.3
75 x 115	7800	72	50	62	184	120	8	M10	83	2.4
80 x 120	10400	72	50	62	216	144	10	M10	83	2.5
85 x 125	11100	72	50	62	203	138	10	M10	83	2.6
90 x 130	12900	72	50	62	211	146	11	M10	83	2.7
95 x 135	13600	72	50	62	200	141	11	M10	83	2.9
100 x 145	19400	84	60	72	215	148	10	M12	145	4.1
110 x 155	21400	84	60	72	195	138	10	M12	145	4.3
120 x 165	25600	84	60	72	197	143	11	M12	145	4.6
130 x 180	35300	93	65	81	205	148	14	M12	145	6.4
140 x 190	40800	94	65	82	204	151	15	M12	145	6.7
150 x 200	43700	94	65	82	191	143	15	M12	145	7.2
160 x 210	49700	94	65	82	191	145	16	M12	145	7.6
170 x 225	67500	107	78	93	194	146	15	M14	230	10.5
180 x 235	71500	107	78	93	183	140	15	M14	230	10.9
190 x 250	80500	119	88	105	156	118	16	M14	230	14.2
200 x 260	105000	119	88	105	183	141	18	M14	230	14.6
220 x 285	119000	127	96	111	159	123	15	M16	355	18.9
240 x 305	173000	127	96	111	194	153	20	M16	355	20.0
260 x 325	197000	127	96	111	188	151	21	M16	355	21.5
280 x 355	237000	131	96	111	211	167	15	M20	690	27.0
300 x 375	254000	131	96	111	197	158	15	M20	690	29.7
320 x 405	362000	156	124	136	195	154	20	M20	690	43.5
340 x 425	384000	156	124	136	184	147	20	M20	690	46.5
360 x 455	499000	182	140	160	170	135	20	M22	930	66.0
380 x 475	526000	182	140	160	161	129	20	M22	930	68.5
400 x 495	610000	182	140	160	168	136	22	M22	930	72.0

Locking Device

optional
nickel-plated version
optional full stainless
steel version

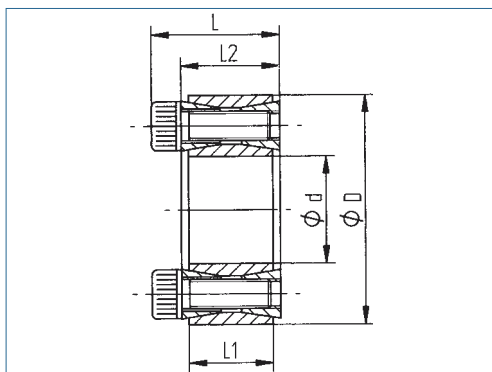

transmittable torque	medium
surface pressure on hub	high
self-centering	no
axial movement of the hub during assembly	no
height D/d	high
overall length	short

Order Code

KBS 40 - 75 x 115

Type

Ød

ØD

Recommended finishing tolerances of contact surfaces are: shaft h11 / hub H11

Inner / Outer Ø dxD	Torque T Nm	Dimensions			Surface pressure on		Screws			Mass kg
		L mm	L1 mm	L2 mm	Shaft Pw N/mm ²	Hub Pn N/mm ²	No.	ISO 4762	TA Nm	
19 x 47	255	28	17	20	220	90	8	M6x18	14	0.20
20 x 47	270	28	17	20	210	90	8	M6x18	14	0.20
22 x 47	300	28	17	20	195	90	8	M6x18	14	0.20
24 x 50	360	28	17	20	195	95	9	M6x18	14	0.23
25 x 50	380	28	17	20	190	95	9	M6x18	14	0.21
28 x 55	500	28	17	20	187	96	10	M6x18	14	0.25
30 x 55	530	28	17	20	176	96	10	M6x18	14	0.26
32 x 60	630	28	17	20	192	105	12	M6x18	14	0.27
35 x 60	700	28	17	20	180	105	12	M6x18	14	0.28
38 x 65	860	28	17	20	183	107	14	M6x18	14	0.30
40 x 65	910	28	17	20	180	110	14	M6x18	14	0.30
42 x 75	1500	32	20	24	226	125	12	M8x22	35	0.55
45 x 75	1610	32	20	24	210	125	12	M8x22	35	0.56
48 x 80	1700	32	20	24	196	115	12	M8x22	35	0.57
50 x 80	1770	32	20	24	190	115	12	M8x22	35	0.58
55 x 85	2270	32	20	24	200	130	14	M8x22	35	0.60
60 x 90	2470	32	20	24	180	120	14	M8x22	35	0.65
65 x 95	3040	32	20	24	190	130	16	M8x22	35	0.70
70 x 110	4600	38	24	28	210	130	14	M10x25	70	1.25
75 x 115	4900	38	24	28	195	125	14	M10x25	70	1.30
80 x 120	5200	38	24	28	180	120	14	M10x25	70	1.35
85 x 125	6300	38	24	28	195	130	16	M10x25	70	1.45
90 x 130	6600	38	24	28	180	125	16	M10x25	70	1.53
95 x 135	7900	38	24	28	195	135	18	M10x25	70	1.62
100 x 145	9600	47	26	33	195	135	14	M12x30	125	2.10
110 x 155	10500	47	26	33	180	125	14	M12x30	125	2.25
120 x 165	13100	47	26	33	185	135	16	M12x30	125	2.45
130 x 180	17600	52	34	38	165	115	20	M12x35	125	3.45
140 x 190	20900	52	34	38	165	125	22	M12x35	125	3.65
150 x 200	24200	52	34	38	170	125	24	M12x35	125	3.90
160 x 210	28000	52	34	38	170	130	26	M12x35	125	4.45
170 x 225	32800	60	38	44	160	120	22	M14x40	190	5.45
180 x 235	37800	60	38	44	165	125	24	M14x40	190	6.05
190 x 250	46500	68	46	52	150	115	28	M14x45	190	8.25
200 x 260	52500	68	46	52	150	115	30	M14x45	190	8.65
220 x 285	68000	74	50	56	150	115	26	M16x50	295	11.15

Locking Device

optional
nickel-plated version
optional full stainless
steel version

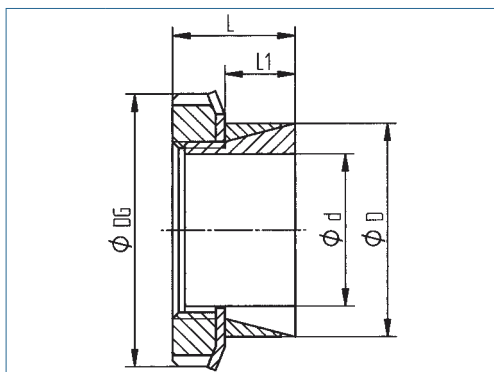

transmittable torque	low
surface pressure on hub	low
self-centering	no
axial movement of the hub during assembly	no
height D/d	flat
overall length	short

Order Code

KBS 51 - 20 x 30

Type

ϕd

ϕD

Recommended finishing tolerances of contact surfaces are: shaft h8 / hub H8

Inner / Outer dxD	Torque T Nm	Dimensions			Surface pressure on		Nut		Mass kg
		DG mm	L mm	L1 mm	Shaft Pw N/mm ²	Hub Pn N/mm ²	Size	TA Nm	
14 x 25	52	32	17	6.5	217	68	M20x1	95	0.05
15 x 25	56	32	17	6.5	203	73	M20x1	95	0.05
16 x 25	60	32	17	6.5	191	78	M20x1	95	0.04
17 x 25	65	32	17	6.5	184	85	M20x1	95	0.04
18 x 30	91	38	17.5	6.5	229	83	M25x1.5	160	0.08
19 x 30	96	38	18	6.5	217	87	M25x1.5	160	0.08
20 x 30	102	38	18	6.5	139	93	M25x1.5	160	0.08
22 x 35	115	45	18	6.5	194	77	M30x1.5	220	0.11
24 x 35	139	45	18	6.5	197	93	M30x1.5	220	0.09
25 x 35	144	45	18	6.5	188	96	M30x1.5	220	0.10
28 x 40	215	52	18	6.5	224	110	M35x1.5	340	0.12
30 x 40	230	52	20	8	169	95	M35x1.5	340	0.13
32 x 45	315	58	22	8	204	103	M40x1.5	480	0.19
35 x 45	331	58	22	8	179	108	M40x1.5	480	0.17
36 x 45	340	58	22	8	174	111	M40x1.5	480	0.17
38 x 50	450	65	25	10	165	95	M45x1.5	680	0.23
40 x 50	477	65	25	10	158	101	M45x1.5	680	0.24
42 x 55	580	70	26	10	174	102	M50x1.5	870	0.30
45 x 55	617	70	26	10	162	108	M50x1.5	870	0.28
48 x 60	669	75	26	10	154	99	M55x2	970	0.33
50 x 60	697	75	26	10	148	103	M55x2	970	0.35
55 x 65	796	80	27	12	116	83	M60x2	1100	0.36
56 x 68	620	80	27.5	12	87	59	M60x2	1100	0.34
60 x 70	946	85	29	12	116	85	M65x2	1300	0.42
63 x 79	890	92	30.5	13.5	88	56	M70x2	1300	0.56
65 x 79	920	92	30.5	13.5	86	58	M70x2	1300	0.52
70 x 84	1433	98	31.5	13.5	115	810	M75x2	2000	0.52

Locking Device

optional
nickel-plated version
optional full stainless
steel version



KBK

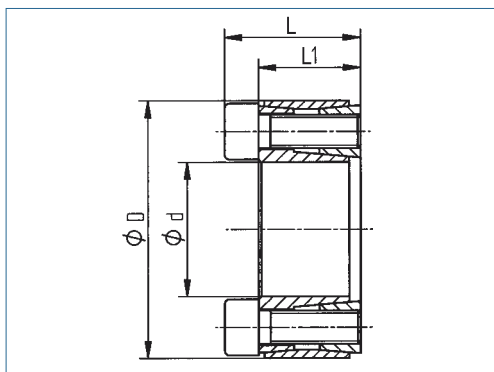

transmittable torque	medium
surface pressure on hub	medium
self-centering	yes
axial movement of the hub during assembly	no
height D/d	medium
overall length	short

Order Code

KBS 52 - 20 x 42

Type

Ød

ØD

Recommended finishing tolerances of contact surfaces are: shaft h8 / hub H8

Inner / Outer dxD	Torque T Nm	Dimensions		Surface pressure on		Screws			Mass kg
		L mm	L1 mm	Shaft Pw N/mm ²	Hub Pn N/mm ²	No.	ISO 4762	TA Nm	
16 x 32	82	21	17	135	68	4	M4x14	5	0.07
18 x 40	211	24	18	234	105	4	M6x16	17	0.12
19 x 41	223	24	18	221	103	4	M6x16	17	0.12
20 x 42	235	24	18	210	100	4	M6x16	17	0.13
22 x 44	258	24	18	191	96	4	M6x16	17	0.14
24 x 46	423	24	18	175	91	6	M6x16	17	0.15
25 x 47	440	24	18	224	119	6	M6x16	17	0.17
28 x 50	493	24	18	200	112	6	M6x16	17	0.17
30 x 52	528	24	18	187	108	6	M6x16	17	0.17
32 x 54	564	24	18	175	104	6	M6x16	17	0.22
35 x 57	822	28	22	221	136	8	M6x18	17	0.23
36 x 58	845	28	22	215	134	8	M6x18	17	0.25
38 x 60	892	28	22	204	129	8	M6x18	17	0.28
40 x 62	939	28	22	194	125	8	M6x18	17	0.29
42 x 70	1784	36	28	265	159	8	M8x25	41	0.46
45 x 73	1911	36	28	247	152	8	M8x25	41	0.50
48 x 76	2039	36	28	232	146	8	M8x25	41	0.51
50 x 78	2124	36	28	223	143	8	M8x25	41	0.52
55 x 83	2628	36	28	270	179	9	M8x25	41	0.62
60 x 88	2867	36	28	247	169	9	M8x25	41	0.65
65 x 93	3106	36	28	228	160	9	M8x25	41	0.69
70 x 105	5287	45	35	233	155	9	M10x25	83	1.20
75 x 110	5664	45	35	217	148	9	M10x25	83	1.26
80 x 115	6042	45	35	271	189	9	M10x25	83	1.35
85 x 120	7133	45	35	255	181	10	M10x25	83	1.40
90 x 125	7553	45	35	241	174	10	M10x25	83	1.46
95 x 130	7972	45	35	228	167	10	M10x25	83	1.50
100 x 138	8392	48	38	206	150	10	M10x25	83	1.75
110 x 148	9231	48	38	188	139	10	M10x25	83	2.20

Locking Device

optional
nickel-plated version
optional full stainless
steel version

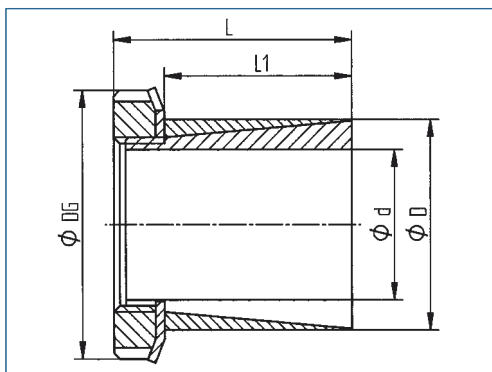

transmittable torque	low
surface pressure on hub	low
self-centering	yes
axial movement of the hub during assembly	no
height D/d	flat
overall length	long

Order Code

KBS 55 - 20 x 30

Type

Ød

ØD

Recommended finishing tolerances of contact surfaces are: shaft h8 / hub H8

Inner / Outer Ø dxD	Torque T Nm	Dimensions			Surface pressure on		Nut		Mass kg
		DG mm	L mm	L1 mm	Shaft Pw N/mm ²	Hub Pn N/mm ²	Size	TA Nm	
14 x 25	65	32	31	23	76	24	M20x1	95	0.08
15 x 25	70	32	31	23	72	26	M20x1	95	0.08
16 x 25	80	32	31	23	72	30	M20x1	95	0.07
17 x 25	100	32	31	23	80	37	M20x1	95	0.07
18 x 30	100	38	33	24	68	25	M25x1.5	160	0.13
19 x 30	105	38	33	24	64	26	M25x1.5	160	0.13
20 x 30	112	38	33	24	62	28	M25x1.5	160	0.13
22 x 35	175	45	38	29	66	26	M30x1.5	220	0.19
24 x 35	178	45	38	29	57	27	M30x1.5	220	0.17
25 x 35	185	45	38	29	54	28	M30x1.5	220	0.17
28 x 40	250	52	44	34	50	24	M35x1.5	340	0.22
30 x 40	270	52	44	34	47	26	M35x1.5	340	0.24
32 x 45	370	58	45	34	56	29	M40x1.5	480	0.32
35 x 45	390	58	45	34	50	30	M40x1.5	480	0.29
36 x 45	420	58	45	34	51	32	M40x1.5	480	0.29
38 x 50	500	65	46	35	52	30	M45x1.5	680	0.37
40 x 50	520	65	46	35	49	32	M45x1.5	680	0.34
42 x 55	650	70	47	35	56	33	M50x1.5	870	0.46
45 x 55	680	70	47	35	51	34	M50x1.5	870	0.40
48 x 60	840	75	48	36	54	34	M55x2	970	0.49
50 x 60	880	75	48	36	52	36	M55x2	970	0.44
55 x 65	1030	80	48	36	50	36	M60x2	970	0.48
56 x 68	806	80	48.5	36	38	26	M60x2	1100	0.50
60 x 70	1360	85	50	36	56	41	M65x2	1300	0.59
63 x 79	1150	92	50	36	43	27	M70x2	1300	0.80
65 x 79	1200	92	50	36	42	28	M70x2	1300	0.76

Locking Device

optional full stainless steel version

nickel-zinc-plating inclusive

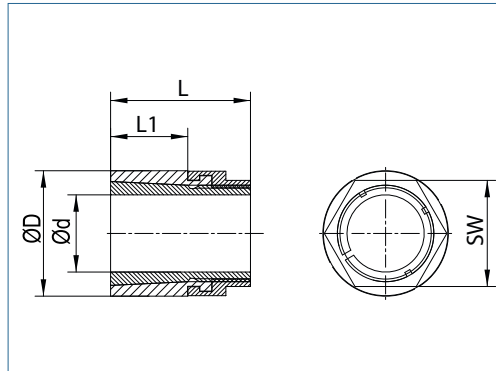

transmittable torque	low
surface pressure on hub	low
self-centering	yes
axial movement of the hub during assembly	yes
height D/d	flat
overall length	short

Order Code **KBS 56 - 8 x 20**
Type Ød ØD

Recommended finishing tolerances of contact surfaces are: shaft js 9 / hub JS 9

Inner / Outer d x D	Torque T Nm	Dimensions			Surface pressure on		Axial Force F _{AX} (kN)	T _A (Nm)	Mass g
		L mm	L 1 mm	SW mm	Shaft P _w N/mm ²	Hub P _n N/mm ²			
5 x 16	11	19	10	13	233	23	4	10	19.0
6 x 16	13	19	10	13	192	27	4	10	18.0
7 x 20	35	22	11	16	344	42	10	28	34.0
8 x 20	40	22	11	16	301	48	10	28	33.0
9 x 20	45	22	11	16	268	54	10	28	32.0
10 x 23	65	26	13	19	265	50	13	44	49.0
11 x 23	72	26	13	19	243	56	13	44	47.0
12 x 23	79	26	13	19	224	61	13	44	45.0
14 x 26	118	29	16	22	200	58	17	66	65.0
15 x 26	126	29	16	22	186	62	17	66	62.0
16 x 26	135	29	16	22	175	66	17	66	59.0
20 x 45	290	48	22	45	175	35	29	85	82.0
22 x 45	315	48	22	45	157	38	29	85	84.0
24 x 45	380	48	22	45	159	45	31	85	89.0
25 x 45	390	48	22	45	150	46	31	85	93.0

Locking Device

stainless steel
execution

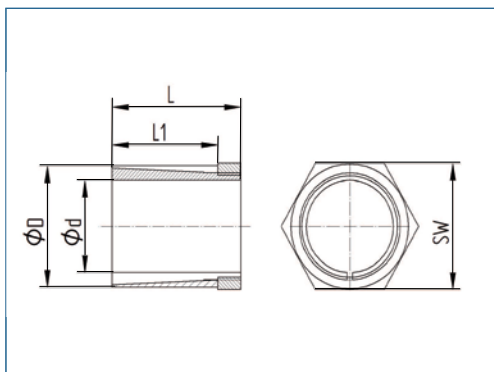
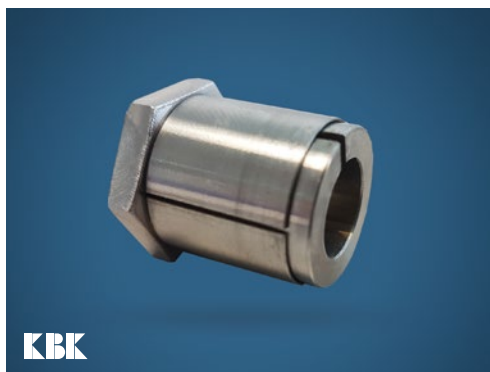

transmittable torque	low
surface pressure on hub	low
self-centering	yes
axial movement of the hub during assembly	yes
height D/d	flat
overall length	short

Order Code

KBS 57 - 9 x 14

Type

Ød

ØD

Recommended finishing tolerances of contact surfaces are: shaft h8 / hub H8

Inner / Outer Ø d x D	Torque T Nm	Dimensions			Surface pressure on		Nut G	T _A (Nm)	Mass g
		L mm	L 1 mm	SW mm	Shaft P _w N/mm ²	Hub P _n N/mm ²			
4 x 8	3	15	12.5	8	80	20	M6 x 0.5	4	3.8
5 x 10	4	15	12.5	10	68	17	M8 x 0.5	5	6.5
6 x 10	7	15	12.5	10	83	30	M8 x 0.5	8	5.3
6.35 x 10	7	15	12.5	10	74	30	M8 x 0.5	8	5.0
7 x 12	8	15	12	12	69	24	M10 x 0.75	9	6.3
8 x 14	14	22	19	16	61	20	M12 x 1.0	15	17.5
9 x 14	14	22	19	16	48	20	M12 x 1.0	15	15.0
9.52 x 14	14	22	19	16	43	20	M12 x 1.0	15	12.8
10 x 17	18	22	18.5	18	52	18	M15 x 1.0	19	29.0
11 x 17	18	22	18.5	18	43	18	M15 x 1.0	19	28.0
12 x 17	18	22	18.5	18	36	18	M15 x 1.0	19	26.2
14 x 20	24	28	23	22	28	14	M17 x 1.0	25	35.3
15 x 20	24	28	23	22	25	14	M17 x 1.0	25	36.4
15.88 x 23	26	28	23	26	24	11	M20 x 1.0	27	48.4
16 x 23	26	28	23	26	23	11	M20 x 1.0	27	50.7
17 x 23	26	28	23	26	21	11	M20 x 1.0	27	45.0
19 x 25	29	28	23	30	19	11	M22 x 1.0	30	46.9
20 x 28	31	28	23	30	18	9	M22 x 1.0	32	67.0
25 x 32	45	35	27	34	14	9	M28 x 1.0	42	89.0
30 x 37	52	35	27	38	11	7	M33 x 1.0	47	105.0
35 x 43	57	40	29	48	9	6	M39 x 1.5	52	179.0
40 x 50	95	40	29	55	11	7	M45 x 1.5	58	249.0

Locking Device

optional full stainless steel version

nickel-zinc-plating inclusive

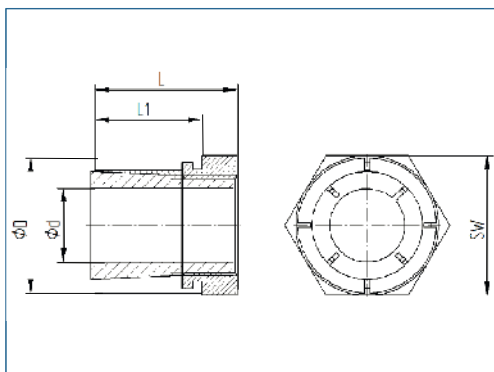

transmittable torque	medium
surface pressure on hub	medium
self-centering	yes
axial movement of the hub during assembly	yes
height D/d	medium
overall length	medium

Order Code **KBS 58 - 9 x 20**
Type Ød ØD

Recommended finishing tolerances of contact surfaces are: Shaft h8 / hub H8

Inner / Outer Ø d x D	Torque T Nm	Dimensions			Surface pressure on		TA	Axial Force F _{AX(1N)}	Mass g
		L mm	L 1 mm	SW mm	Shaft Pw N/mm ²	Hub Pn N/mm ²			
5 x 14	10	19	15	14	264	97	10	4.0	18.0
6 x 14	12	19	15	14	220	96	10	4.0	17.0
7 x 16	20	22	17	16	205	91	17	5.8	26.0
8 x 16	23	22	17	16	180	91	17	5.8	24.0
9 x 20	43	24	19	22	246	115	35	9.7	47.0
10 x 20	48	24	19	22	221	115	35	9.7	44.0
11 x 22	59	24	19	22	225	117	44	10.8	51.0
12 x 22	65	24	19	22	207	117	44	10.9	48.0
14 x 26	93	28	22	27	179	99	65	13.3	81.0
15 x 26	99	28	22	27	167	99	65	13.3	75.0
16 x 26	106	28	22	27	156	99	65	13.3	71.0
17 x 32	163	34	26	32	187	108	110	19.2	149.0
18 x 35	223	36	27	36	224	125	161	24.8	197.0
19 x 35	235	36	27	36	213	125	161	24.8	189.0
20 x 35	248	36	27	36	202	125	161	24.8	182.0
22 x 42	349	41	30	46	197	111	250	31.7	343.0
24 x 42	381	41	30	46	181	111	250	31.7	322.0
25 x 42	397	41	30	46	174	111	250	31.7	310.0
28 x 47	565	44	33	50	174	110	355	40.3	403.0
30 x 47	605	44	33	50	163	110	355	40.3	375.0
32 x 55	764	51	38	55	166	102	490	47.7	626.0
35 x 55	836	51	38	55	152	102	490	47.7	566.0
38 x 62	1140	58	43	65	155	108	700	60.2	897.0
40 x 62	1329	58	43	65	147	108	800	66.5	842.0
42 x 65	1375	63	48	65	140	98	800	67.0	959.0
45 x 65	1605	63	48	65	142	98	900	71.0	855.0
48 x 75	2227	73	58	75	121	77	1290	92.0	1470.0
50 x 75	2320	73	58	75	116	77	1290	92.0	1380.0

Locking Device

optional full stainless steel version

nickel-zinc-plating inclusive

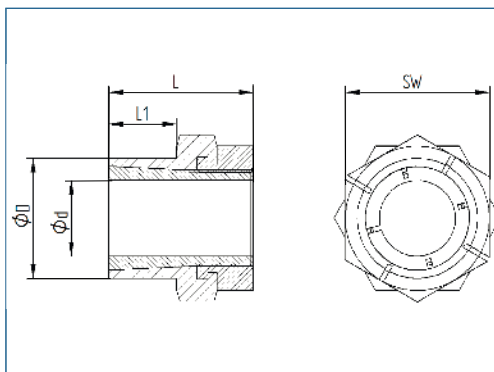

transmittable torque	medium
surface pressure on hub	medium
self-centering	yes
axial movement of the hub during assembly	yes
height D/d	medium
overall length	medium

Order Code **KBS 59 - 10 x 18**
Type Ød ØD

Recommended finishing tolerances of contact surfaces are: shaft h8 / hub H8

Inner / Outer Ø d x D	Torque T Nm	Dimensions			Surface pressure on		TA	Axial Force F _{AX} (kN)	Mass g
		L mm	L 1 mm	SW mm	Shaft Pw N/mm ²	Hub Pn N/mm ²			
5 x 12	10	19	9	14	264	119	10	4.0	16.0
6 x 12	12	19	9	14	220	119	10	4.0	15.0
7 x 14	20	22	11	16	205	121	17	5.8	23.0
8 x 14	23	22	11	16	180	121	17	5.8	21.0
9 x 18	43	24	12	22	246	144	35	9.7	47.0
10 x 18	48	24	12	22	221	144	35	9.7	44.0
11 x 20	59	24	12	22	225	145	44	10.8	47.0
12 x 20	65	24	12	22	207	145	44	10.8	44.0
14 x 24	93	28	15	27	179	118	65	13.3	76.0
15 x 24	99	28	15	27	167	118	65	13.3	72.0
16 x 24	106	28	15	27	156	118	65	13.3	67.0
17 x 26	163	34	16	32	187	148	110	19.2	122.0
18 x 30	223	36	17	36	224	155	160	24.8	176.0
19 x 30	235	36	17	36	213	155	160	24.8	169.0
20 x 30	248	36	17	36	202	155	160	24.8	162.0
22 x 38	349	41	20	46	197	134	250	31.7	338.0
24 x 38	381	41	20	46	181	134	250	31.7	315.0
25 x 38	397	41	20	46	174	134	250	31.7	304.0
28 x 42	565	44	23	50	174	134	355	40.3	370.0
30 x 42	605	44	23	50	163	134	355	40.3	345.0
32 x 50	764	51	28	55	166	112	490	47.7	552.0
35 x 50	836	51	28	55	152	112	490	47.7	495.0
38 x 58	1140	58	32	65	155	116	700	60.2	851.0
40 x 58	1200	58	32	65	147	116	700	60.2	801.0
42 x 60	1250	63	37	65	120	94	740	59.6	841.0
45 x 60	1340	63	37	65	112	94	740	59.6	741.0

Locking Device

optional
nickel-plated version
optional full stainless
steel version

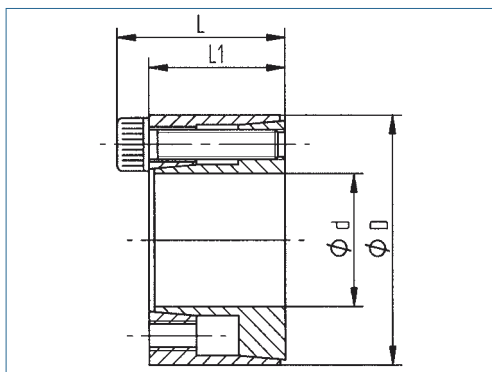

transmittable torque	medium
surface pressure on hub	low
self-centering	yes
axial movement of the hub during assembly	yes
height D/d	medium
overall length	medium

Order Code

KBS 61 - 15 x 28

Type

Ød

ØD

Recommended finishing tolerances of contact surfaces are: shaft h8 / hub H8

Inner / Outer Ø dxD	Torque T Nm	Dimensions		Surface pressure on		Screws			Mass kg
		L mm	L1 mm	Shaft Pw N/mm²	Hub Pn N/mm²	No.	ISO 4762	TA Nm	
5 x 16	6	13.5	11	150	55	3	M2.5x10	1.2	0.012
6 x 16	6	13.5	11	150	55	3	M2.5x10	1.2	0.012
6.35 x 16	6	13.5	11	140	55	3	M2.5x10	1.2	0.012
7 x 17	8	13.5	11	125	55	3	M2.5x10	1.2	0.013
8 x 18	10	13.5	11	110	50	3	M2.5x10	1.2	0.015
9 x 20	15	15.5	13	120	55	4	M2.5x12	1.2	0.020
9.53 x 20	15	15.5	13	110	55	4	M2.5x12	1.2	0.020
10 x 20	15	15.5	13	110	55	4	M2.5x12	1.2	0.019
11 x 22	18	15.5	13	100	50	4	M2.5x12	1.2	0.024
12 x 22	20	15.5	13	90	50	4	M2.5x12	1.2	0.022
14 x 26	35	20	17	105	55	4	M3x16	2.1	0.039
15 x 28	40	20	17	100	50	4	M3x16	2.1	0.044
16 x 32	70	21	17	130	65	4	M4x16	4.9	0.067
17 x 35	75	25	21	120	60	4	M4x20	4.9	0.090
18 x 35	80	25	21	115	60	4	M4x20	4.9	0.087
19 x 35	85	25	21	110	60	4	M4x20	4.9	0.083
20 x 38	220	26	21	220	115	6	M5x20	9.7	0.100
22 x 40	240	26	21	200	110	6	M5x20	9.7	0.110
24 x 47	380	32	26	220	110	6	M6x25	16.5	0.200
25 x 47	390	32	26	210	110	6	M6x25	16.5	0.190
25.4 x 47	390	32	26	210	110	6	M6x25	16.5	0.190
28 x 50	440	32	26	185	100	6	M6x25	16.5	0.220
30 x 55	470	32	26	175	95	6	M6x25	16.5	0.270
32 x 55	500	32	26	165	95	6	M6x25	16.5	0.250
35 x 60	730	37	31	165	95	8	M6x30	16.5	0.360
38 x 65	800	37	31	155	90	8	M6x30	16.5	0.430
40 x 65	840	37	31	145	90	8	M6x30	16.5	0.400
42 x 75	1200	44	36	165	90	6	M8x35	40	0.670
45 x 75	1300	44	36	155	90	6	M8x35	40	0.630
48 x 80	1850	44	36	195	115	8	M8x35	40	0.740
50 x 80	1900	44	36	185	115	8	M8x35	40	0.700

Locking Device

optional
nickel-plated version
optional full stainless
steel version



KBK

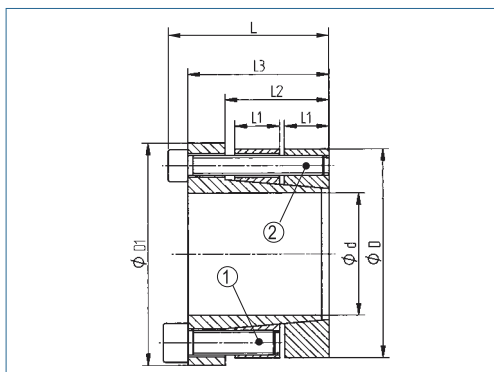

transmittable torque	high
surface pressure on hub	medium
self-centering	yes
axial movement of the hub during assembly	no
height D/d	high
overall length	long

Order Code

KBS 62 - 240 x 310

Type Ød ØD

Recommended finishing tolerances of contact surfaces are: shaft h8 / hub H8

Inner / Outer Ø dxD	Dimensions					Screw				Torque			Surface pressure on				Mass kg
	D1 mm	L1 mm	L2 mm	L3 mm	L mm	1	TA 1 Nm	2	TA 2 Nm	T1 Nm	T2 Nm	T Nm	1 Shaft Hub N/mm²	2 Shaft Hub N/mm²	Hub N/mm²	Hub N/mm²	
30 x 60	66	15	36	48	56	M8	41	M6	17	620	330	950	243	121	131	66	0.8
32 x 65	71	15	36	48	56	M8	41	M6	17	660	450	1110	227	112	154	76	0.9
35 x 65	71	15	36	48	56	M8	41	M6	17	720	490	1210	208	112	141	76	0.9
38 x 70	76	15	36	48	56	M8	41	M6	17	980	530	1510	239	130	130	70	1.0
40 x 70	76	15	36	48	56	M8	41	M6	17	1030	560	1590	227	130	123	70	1.0
42 x 80	86	18	42	57	67	M 10	83	M8	41	1420	1080	2500	237	124	181	95	1.6
45 x 80	86	18	42	57	67	M 10	83	M8	41	1520	1160	2680	221	124	168	95	1.5
48 x 85	91	18	42	57	67	M 10	83	M8	41	2030	1230	3260	259	146	158	89	1.7
50 x 85	91	18	42	57	67	M 10	83	M8	41	2110	1290	3400	249	146	152	89	1.6
55 x 90	96	18	42	57	67	M 10	83	M8	41	2320	1410	3730	226	138	138	84	1.7
60 x 95	101	18	42	57	67	M 10	83	M8	41	3040	1850	4890	249	157	152	96	1.9
65 x 100	106	18	42	57	67	M 10	83	M8	41	3290	2010	5300	230	149	140	91	2.0
70 x 115	121	24	56	74	86	M 12	145	M 10	83	5300	3550	8850	239	145	160	97	3.6
75 x 125	131	24	56	74	86	M 12	145	M 10	83	6620	4430	11050	260	156	174	105	4.3
80 x 125	131	24	56	74	86	M 12	145	M 10	83	7060	4730	11790	244	156	163	105	4.0
85 x 135	141	24	56	74	86	M 12	145	M 10	83	7500	5020	12520	230	145	154	97	4.7
90 x 135	141	24	56	74	86	M 12	145	M 10	83	7950	5320	13270	217	145	145	97	4.3
95 x 150	156	26	67	82	96	M 14	230	M 12	145	11300	8390	19690	255	162	190	120	6.1
100 x 150	156	26	67	82	96	M 14	230	M 12	145	11900	8830	20730	242	162	180	120	5.6
110 x 160	166	26	67	82	96	M 14	230	M 12	145	13100	9710	22810	220	151	164	113	6.1
120 x 170	176	26	67	82	96	M 14	230	M 12	145	14300	10600	24900	202	143	150	106	6.5
130 x 190	196	30	71	95	111	M 16	355	M 14	230	24200	17600	41800	253	173	185	126	10.5
140 x 200	206	30	71	95	111	M 16	355	M 14	230	26000	19000	45000	235	164	171	120	11.3
150 x 210	216	30	71	95	111	M 16	355	M 14	230	27900	20400	48300	219	157	160	114	11.8
160 x 220	226	30	71	95	111	M 16	355	M 14	230	29700	21700	51400	205	149	150	109	12.5
170 x 250	256	40	92	122	142	M 20	690	M 16	355	49400	31600	81000	227	154	145	99	24.1
180 x 250	256	40	92	122	142	M 20	690	M 16	355	52300	33500	85800	214	154	137	99	21.5
190 x 270	276	40	92	122	142	M 20	690	M 16	355	69000	44100	113100	254	178	162	114	26.3
200 x 270	276	40	92	122	142	M 20	690	M 16	355	72700	46500	119200	241	178	154	114	23.6
220 x 290	296	40	92	122	142	M 20	690	M 16	355	79900	51100	131000	219	166	140	106	25.5
240 x 310	316	40	92	122	142	M 20	690	M 16	355	105000	66900	171900	241	186	154	119	27.6
260 x 330	336	40	92	122	142	M 20	690	M 16	355	113000	72500	185500	222	175	142	112	29.6
280 x 365	371	45	108	144	168	M 24	1200	M 20	690	148000	102000	250000	223	171	153	117	45.5
300 x 385	391	45	108	144	168	M 24	1200	M 20	690	159000	109000	268000	208	162	143	111	48.3
340 x 425	431	45	108	144	168	M 24	1200	M 20	690	252000	173000	425000	257	206	176	141	53.9
380 x 465	471	45	108	144	168	M 24	1200	M 20	690	322000	221000	543000	263	215	180	147	59.6

Locking Device

optional
nickel-plated version
optional full stainless
steel version

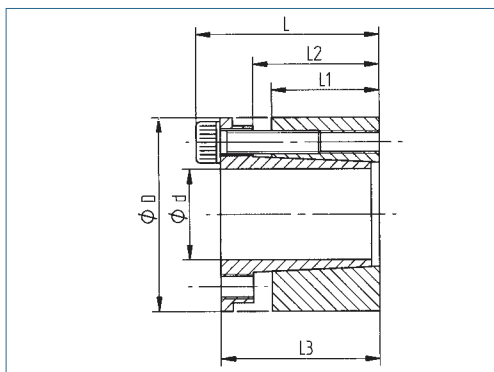

transmittable torque	high
surface pressure on hub	medium
self-centering	yes
axial movement of the hub during assembly	yes
height D/d	high
overall length	medium

Order Code

KBS 70 - 48 x 80

Type Ød ØD

Recommended finishing tolerances of contact surfaces are: shaft h8 / hub H8

Inner / Outer Ø dxD	Torque T Nm	Dimensions				Surface pressure on		Screws			Mass kg
		L mm	L1 mm	L2 mm	L3 mm	Shaft Pw N/mm ²	Hub Pn N/mm ²	No.	ISO 4762	TA Nm	
19 x 47	350	45	26	31	39	228	98	4	M6x25	17	0.34
20 x 47	390	45	26	31	39	231	100	4	M6x25	17	0.34
22 x 47	440	45	26	31	39	220	95	4	M6x25	17	0.33
24 x 50	519	45	26	31	39	215	102	6	M6x25	17	0.35
25 x 50	590	45	26	31	39	230	105	6	M6x25	17	0.35
28 x 55	700	45	26	31	39	220	110	6	M6x25	17	0.39
30 x 55	760	45	26	31	39	200	120	6	M6x25	17	0.41
32 x 60	930	45	26	31	39	230	114	8	M6x25	17	0.50
35 x 60	1030	45	26	31	39	200	119	8	M6x25	17	0.45
38 x 65	1240	45	26	31	39	210	124	8	M6x25	17	0.55
40 x 65	1350	45	26	31	39	200	125	8	M6x25	17	0.50
42 x 75	2170	55	30	36	47	236	140	6	M8x30	41	0.90
45 x 75	2350	55	30	36	47	236	140	6	M8x30	41	0.90
48 x 80	2510	55	30	36	47	218	135	6	M8x30	41	0.95
50 x 80	2580	55	30	36	47	218	135	6	M8x30	41	0.97
55 x 85	3200	55	30	36	47	223	145	8	M8x30	41	1.00
60 x 90	3380	55	30	36	47	198	157	8	M8x30	41	1.10
65 x 95	4160	55	30	36	47	213	140	8	M8x30	41	2.30
70 x 110	6840	67	40	46	57	225	143	8	M10x35	83	2.25
75 x 115	7500	72	40	46	62	210	138	8	M10x35	83	2.55
80 x 120	8100	72	40	46	62	200	130	8	M10x35	83	2.70
85 x 125	9700	72	40	46	62	210	145	10	M10x35	83	2.80
90 x 130	10300	72	40	46	62	200	138	10	M10x35	83	2.85
95 x 135	12100	72	40	46	62	210	148	10	M10x35	83	2.90
100 x 145	15700	89	46	52	77	216	148	8	M12x45	145	4.75
110 x 155	17200	89	46	52	77	196	139	8	M12x45	145	5.00
120 x 165	22500	89	46	52	77	216	156	10	M12x45	145	5.40
130 x 180	24000	89	46	52	77	196	140	12	M12x45	145	5.70
140 x 190	30800	98	51	59	84	196	145	8	M14x45	230	7.15
150 x 200	37150	98	51	59	84	205	153	10	M14x45	230	7.90
160 x 210	40500	98	51	59	84	205	155	10	M14x45	230	8.35
170 x 225	40900	98	51	59	84	163	123	12	M14x45	230	9.40
180 x 235	41300	98	51	59	84	160	120	12	M14x45	230	10.10

Locking Device

optional
nickel-plated version
optional full stainless
steel version

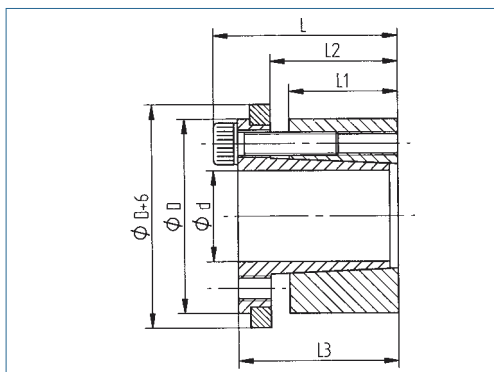

transmittable torque	medium
surface pressure on hub	low
self-centering	yes
axial movement of the hub during assembly	no
height D/d	high
overall length	medium

Order Code

KBS 71 - 30 x 55

Type Ød ØD

Recommended finishing tolerances of contact surfaces are: shaft h8 / hub H8

Inner / Outer Ø dxD	Torque T Nm	Dimensions				Surface pressure on		Screws			Mass kg
		L mm	L1 mm	L2 mm	L3 mm	Shaft Pw N/mm ²	Hub Pn N/mm ²	No.	ISO 4762	TA Nm	
19 x 47	300	45	26	31	39	228	98	4	M6x25	17	0.35
20 x 47	320	45	26	31	39	231	98	4	M6x25	17	0.34
22 x 47	370	45	26	31	39	211	99	4	M6x25	17	0.33
24 x 50	430	45	26	31	39	220	110	6	M6x25	17	0.40
25 x 50	480	45	26	31	39	226	113	6	M6x25	17	0.40
28 x 55	590	45	26	31	39	207	108	6	M6x25	17	0.50
30 x 55	650	45	26	31	39	226	121	6	M6x25	17	0.45
32 x 60	800	45	26	31	39	201	117	8	M6x25	17	0.45
35 x 60	860	45	26	31	39	206	121	8	M6x25	17	0.46
38 x 65	1030	45	26	31	39	201	124	8	M6x25	17	0.50
40 x 65	1130	45	26	31	39	239	146	8	M6x25	17	0.55
42 x 75	1930	55	30	36	47	221	138	6	M8x30	41	1.00
45 x 75	1950	55	30	36	47	221	138	6	M8x30	41	1.00
48 x 80	2180	55	30	36	47	226	145	6	M8x30	41	1.05
50 x 80	2210	55	30	36	47	226	146	6	M8x30	41	1.15
55 x 85	2730	55	30	36	47	226	146	8	M8x30	41	1.15
60 x 90	2910	55	30	36	47	201	134	8	M8x30	41	1.20
65 x 95	3570	55	30	36	47	211	145	8	M8x30	41	2.30
70 x 110	5830	67	40	46	57	226	145	8	M10x35	83	2.30
75 x 115	6330	72	40	46	62	221	151	8	M10x35	83	2.50
80 x 120	6840	72	40	46	62	202	142	8	M10x35	83	2.75
85 x 125	8160	72	40	46	62	221	161	10	M10x35	83	2.90
90 x 130	8670	72	40	46	62	201	146	10	M10x35	83	3.05
95 x 135	10200	72	40	46	62	191	141	10	M10x35	83	3.20
100 x 145	13600	89	46	52	77	201	151	8	M12x45	145	4.70
110 x 155	14870	89	46	52	77	201	182	8	M12x45	145	5.15
120 x 165	19460	89	46	52	77	221	162	10	M12x45	145	5.45
130 x 180	20820	89	46	52	77	202	146	12	M12x45	145	5.50
140 x 190	25410	98	51	59	84	192	141	8	M14x45	230	7.30
150 x 200	30720	98	51	59	84	202	152	10	M14x45	230	8.00
160 x 210	33150	98	51	59	84	202	152	10	M14x45	230	8.50
170 x 225	34000	98	51	59	84	161	121	12	M14x45	230	9.50
180 x 235	34250	98	51	59	84	157	122	12	M14x45	230	10.30

Locking Device

optional
nickel-plated version
optional full stainless
steel version

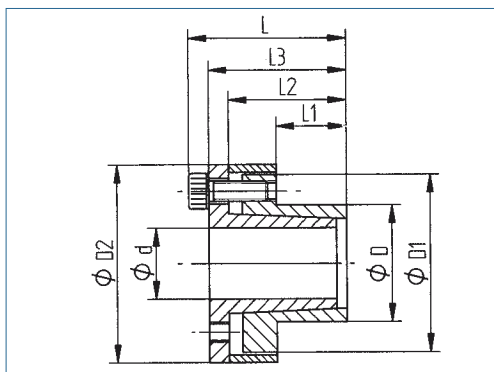

transmittable torque	medium
surface pressure on hub	low
self-centering	yes
axial movement of the hub during assembly	no
height D/d	flat
overall length	medium

Order Code

KBS 80 - 95 x 120

Type

Ød

ØD

Recommended finishing tolerances of contact surfaces are: shaft h8 / hub H8

Inner / Outer Ø dxD	Torque T Nm	Dimensions				Outer Flange D1	Inner Flange D2	Surface pressure on		Screws			Mass kg
		L mm	L1 mm	L2 mm	L3 mm			Shaft Pw N/mm ²	Hub Pn N/mm ²	No.	ISO 4762	TA Nm	
6 x 14	12	25.5	10	18.5	22.5	22	25	190	80	3	M3x10	2.2	0.02
8 x 15	29	29.5	12	21.5	25.5	24	27	205	110	3	M4x12	5	0.06
9 x 16	31	31.5	14	23.5	27.5	25	28	150	85	3	M4x12	5	0.065
10 x 16	35	31.5	14	23.5	27.5	25	28	140	85	3	M4x12	5	0.08
11 x 18	52	31.5	14	23.5	27.5	28	32	170	105	4	M4x12	5	0.09
12 x 18	58	31.5	14	23.5	27.5	28	32	150	100	4	M4x12	5	0.09
14 x 23	69	31.5	14	23.5	27.5	35	39	140	80	4	M4x12	5	0.11
15 x 24	170	42.5	16	29.5	36.5	40	45	158	98	4	M6x18	17	0.21
16 x 24	180	42.5	16	29.5	36.5	40	45	148	98	4	M6x18	17	0.22
17 x 26	200	45.5	19	32.5	39.5	42	47	180	125	4	M6x18	17	0.22
18 x 26	200	45.5	19	32.5	39.5	42	47	180	125	4	M6x18	17	0.22
19 x 27	210	45.5	19	32.5	39.5	43	49	170	120	4	M6x18	17	0.25
20 x 28	220	45.5	19	32.5	39.5	44	50	160	115	4	M6x18	17	0.25
22 x 32	250	52.5	26	39.5	46.5	48	54	115	80	4	M6x18	17	0.30
24 x 34	395	52.5	26	39.5	46.5	50	56	146	102	6	M6x18	17	0.35
25 x 34	410	52.5	26	39.5	46.5	50	56	140	102	6	M6x18	17	0.35
28 x 39	465	52.5	25.5	39.5	46.5	55	61	135	98	6	M6x18	17	0.45
30 x 41	510	52.5	25.5	39.5	46.5	57	62	127	90	6	M6x18	17	0.45
32 x 43	705	52.5	25.5	39.5	46.5	59	65	146	108	8	M6x18	17	0.45
35 x 47	790	58.5	31.5	45.5	52.5	62	69	105	80	8	M6x18	17	0.55
38 x 50	860	58.5	31.5	45.5	52.5	66	72	100	76	8	M6x18	17	0.60
40 x 53	900	58.5	31.5	45.5	52.5	69	75	96	72	8	M6x18	17	0.65
42 x 55	940	58.5	31.5	45.5	52.5	71	78	90	70	8	M6x18	17	0.90
45 x 59	1840	79	45	62.5	71	80	86	110	85	8	M8x22	41	1.10
48 x 62	2000	79	45	62.5	71	81	87	105	80	8	M8x22	41	1.10
50 x 65	2100	79	45	62.5	71	86	92	100	75	8	M8x22	41	1.25
55 x 71	2580	89	55	72.5	81	92	98	85	65	9	M8x22	41	1.50
60 x 77	2800	89	55	72.5	81	98	104	75	60	9	M8x22	41	1.60
65 x 84	3050	89	55	72.5	81	105	111	70	55	9	M8x22	41	1.90
70 x 90	5250	106.5	65	86.5	96.5	113	119	90	70	9	M10x25	83	2.85
75 x 95	5600	106.5	65	86.5	96.5	119	126	80	65	9	M10x25	83	2.95
80 x 100	8000	106.5	65	86.5	96.5	125	131	100	80	12	M10x25	83	3.30
85 x 106	8500	106.5	65	86.5	96.5	131	137	95	75	12	M10x25	83	3.60
90 x 112	9000	106.5	65	86.5	96.5	137	144	90	75	12	M10x25	83	3.90
95 x 120	11000	106.5	65	86.5	96.5	142	149	100	80	14	M10x25	83	4.30
100 x 125	15000	106.5	65	86.5	96.5	147	154	120	95	18	M10x25	83	4.65
110 x 140	16000	140	90	114	128	172	180	80	65	12	M12x35	145	8.20
120 x 155	17500	140	90	114	128	187	198	70	55	12	M12x35	145	10.50

SHRINK DISCS, LOCKING ELEMENTS AND RIGID SHAFT COUPLINGS

KBS 19 | 14 - 48

Shrink Disc



P. 29

KBS 19 | 50 - 125

Shrink Disc



P. 30

KBS 19 | 140 - 280

Shrink Disc



P. 31

KBS 19/1

Shrink Disc



P. 32

KBS 50 | 6 - 56

Locking Element



P. 33

KB 50 | 60 - 220

Locking Element



P. 34

KBS 95

Rigid Shaft Coupling



P. 35

Shrink Disc

optional
nickel-plated version
optional full stainless
steel version

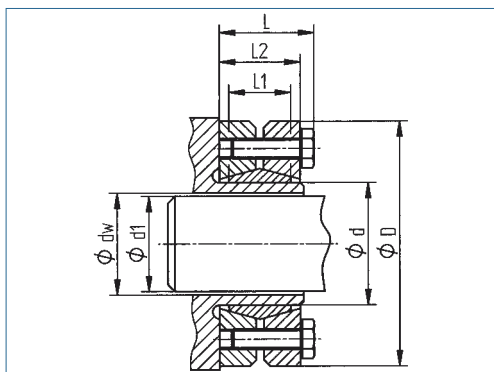

transmittable torque	medium
surface pressure on hub	medium
self-centering	no
height D/d	medium
overall length	medium

Order Code **KBS 19 - 165 x 290**
Type Ød ØD

Recommended finishing tolerances of contact surfaces are: shaft d h 9

Hollow Ød mm	Shaft Ø dw mm	Outer ØD mm	Torque T Nm	Dimensions				Fitting Tolerance max. mm	Surface pressure on	Screws			Mass kg
				L mm	L1 mm	L2 mm	Shaft Pw N/mm²		No.	ISO 4017	TA Nm		
14	10	38	40	18.5	10	15	0.014	154	4	M5x12	3	0.10	
	50		191										
	65		243										
16	12	41	65	20.5	12	17	0.014	108	5	M5x12	3	0.14	
	80		151										
	95		190										
18	14	44	85	20.5	12	17	0.014	172	4	M5x12	4	0.15	
	100		205										
	130		233										
20	15	46	110	20.5	12	17	0.017	205	5	M5x12	4	0.17	
	130		232										
	150		258										
21	16	50	180	23.5	14	20	0.017	220	6	M5x12	5	0.23	
	220		245										
	270		275										
24	19	50	220	23.5	14	20	0.017	189	6	M5x18	4	0.22	
	280		209										
	330		228										
30	24	60	350	25.5	16	22	0.017	159	7	M5x18	4	0.33	
	400		172										
	470		184										
36	28	72	730	27.5	18	23.5	0.032	232	5	M6x20	12	0.52	
	860		240										
	880		250										
38	29	72	710	28,5	19	24,5	0,032	198	6	M6x20	12	0.5	
	735		205										
	760		211										
40	30	72	770	28,5	19,0	24,5	0,032	216	6	M6x20	12	0.5	
	800		223										
	825		230										
44	32	80	1200	29.5	20	25.5	0.032	225	7	M6x20	12	0.64	
	1400		235										
	1500		244										
48	36	80	1350	29.5	20	25.5	0.032	222	7	M6x20	12	0.60	
	1450		236										
	1530		248										

Shrink Disc

optional
nickel-plated version
optional full stainless
steel version

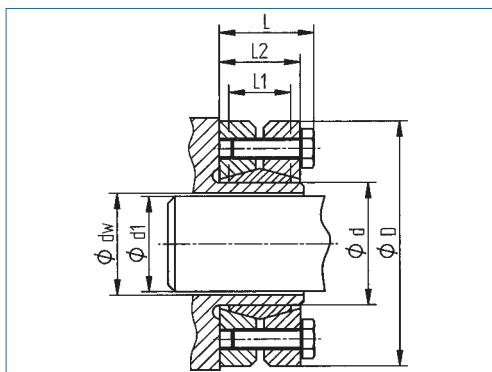

transmittable torque	medium
surface pressure on hub	medium
self-centering	no
height D/d	medium
overall length	medium

Order Code **KBS 19 - 165 x 290**
Type Ød ØD

Recommended finishing tolerances of contact surfaces are: shaft d h 9

Hollow Ød mm	Shaft Ø dw mm	Outer ØD mm	Torque T Nm	Dimensions				Fitting Tolerance max. mm	Surface pressure on	Screws			Mass kg
				L mm	L1 mm	L2 mm	Shaft Pw N/mm²		No.	ISO 4017	TA Nm		
50	38	90	1500	31.5	22	27.5	0.032	204	8	M6x25	12	0.87	
	40		219										
	42		232										
55	42	100	1700	34.5	23	30.5	0.032	176	8	M6x25	12	1.18	
	45		193										
	48		210										
62	48	110	2700	34.5	23	30.5	0.048	213	10	M6x25	12	1.41	
	50		218										
	52		222										
68	50	115	2500	34.5	23	30.5	0.048	184	10	M6x25	12	1.46	
	55		188										
	60		212										
75	55	138	3500	37.8	25	32.5	0.048	199	7	M8x30	30	2.45	
	60		221										
	65		241										
80	60	145	4100	37.8	25	32.5	0.048	192	7	M8x30	30	2.66	
	65		211										
	70		228										
85	60	155	6900	44,3	30,0	39,0	0.048	179	10	M8x35	30	3.5	
	65		194										
	70		209										
90	65	155	6200	44.3	30	39	0.048	206	10	M8x35	30	3.4	
	70		222										
	75		236										
95	65	170	7200	49.3	34	44	0.048	197	12	M8x35	30	4.7	
	70		213										
	75		228										
100	70	170	7600	49.3	34	44	0.048	194	12	M8x35	30	4.6	
	75		207										
	80		220										
110	75	185	9100	56.4	39	50	0.048	176	9	M10x40	59	6.0	
	80		188										
	85		183										
115	80	185	10400	56.4	39	50	0.048	177	9	M10x40	59	6.1	
	90		199										
	95		210										
125	85	215	13300	60.4	42	54	0.069	186	12	M10x40	59	8.3	
	90		198										
	95		209										

Shrink Disc

optional
nickel-plated version
optional full stainless
steel version

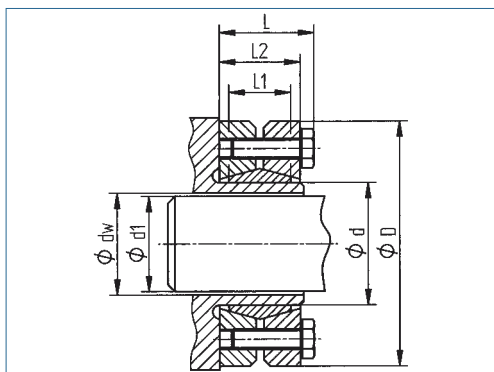

transmittable torque	medium
surface pressure on hub	medium
self-centering	no
height D/d	medium
overall length	medium

Order Code **KBS 19 - 165 x 290**
Type Ød ØD

Recommended finishing tolerances of contact surfaces are: shaft d h 9

Hollow Ød mm	Shaft Ø dw mm	Outer ØD mm	Torque T Nm	Dimensions				Surface pressure on Shaft Pw N/mm²	Screws			Mass kg
				L mm	L1 mm	L2 mm	Fitting Tolerance max. mm		No.	ISO 4017	TA Nm	
140	95	230	18600	68	46	60.5	0.07	190	10	M12x45	100	10
	21600		199									
	24900		208									
155	105	265	25400	72	50	64.5	0.07	195	12	M12x50	100	15
	29000		203									
	32800		211									
165	115	290	38900	81	56	71	0.07	223	8	M16x55	250	22
	43600		230									
	47600		231									
175	125	300	42900	81	56	71	0.08	208	8	M16x55	250	22
	47800		215									
	53100		221									
185	135	330	60000	96	71	86	0.09	197	10	M16x65	250	37
	66400		202									
	73100		208									
195	140	350	75600	96	71	86	0.09	231	12	M16x65	250	41
	90600		241									
	98700		245									
200	150	350	87000	96	71	86	0.09	231	12	M16x65	250	41
	94800		236									
	103000		240									
220	160	370	110000	114	88	104	0.09	208	15	M16x80	250	54
	120000		212									
	129000		216									
240	170	405	146000	121.5	92	109	0.09	233	12	M20x80	490	67
	168000		239									
	190000		243									
260	190	430	197000	132.5	103	120	0.10	225	14	M20x90	490	82
	224000		231									
	254000		237									
280	210	460	260000	146.5	114	134	0.10	220	16	M20x100	490	102
	292000		225									
	327000		230									

Shrink Disc

optional
nickel-plated version
optional full stainless
steel version

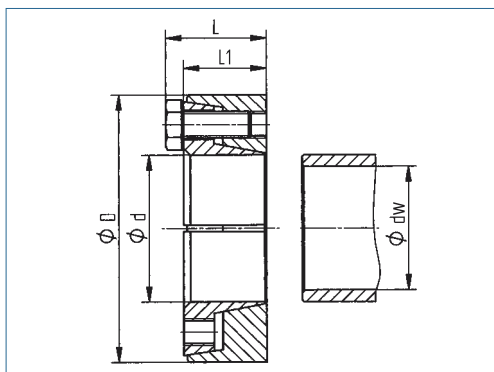

transmittable torque	medium
surface pressure on hub	medium
self-centering	yes
height D/d	medium
overall length	medium

Order Code

KBS 19/1 - 24 x 50

Type Ød ØD

Recommended finishing tolerances of contact surfaces are: shaft d h 9

Hollow Ød mm	Shaft Ø dw mm	Outer ØD mm	Torque T Nm	Dimensions			Surface pressure Shaft Pw N/mm²	Screws			Mass kg
				L mm	L1 mm	Fitting Tolerance max. mm		No.	ISO 4017	TA Nm	
24	19	50	172	22	18	0.017	145	5	M6	12	0.2
	20		218				165				
	21		267				184				
30	24	60	297	24	20	0.017	137	6	M6	12	0.3
	25		352				150				
	26		412				162				
36	28	72	563	27.3	22	0.017	169	5	M8	30	0.5
	30		714				187				
	31		722				177				
44	34	80	734	29.3	24	0.032	135	6	M8	30	0.6
	35		831				144				
	36		933				153				
50	38	90	1230	31.3	26	0.032	166	8	M8	30	0.8
	40		1490				180				
	42		1760				193				
55	42	100	1640	34.3	29	0.032	172	8	M8	30	1.2
	45		2080				190				
	48		2560				206				
62	48	110	1940	34.3	29	0.032	156	9	M8	30	1.4
	50		2230				165				
	52		2340				160				
68	50	115	1810	34.3	29	0.048	134	9	M8	30	1.4
	55		2620				160				
	60		3590				184				
75	55	138	2770	37.4	31	0.048	156	10	M10	59	2.3
	60		3760				178				
	65		4910				197				
80	60	145	3200	37.4	31	0.048	151	10	M10	59	2.5
	65		4230				170				
	70		5400				187				
90	65	155	4730	44.4	38	0.048	159	11	M10	59	3.4
	70		6030				174				
	75		7500				189				
100	70	170	6440	49.4	43	0.048	164	14	M10	59	4.7
	75		7990				177				
	80		9720				190				
110	75	185	8810	56.5	49	0.048	170	12	M12	100	6.2
	80		10600				182				
	85		11700				192				
125	85	215	11600	60.5	53	0.069	163	14	M12	100	9.2
	90		14000				175				
	95		16600				186				
130	85	215	10600	60.5	53	0.069	149	14	M12	100	8.8
	90		12800				161				
	95		15300				171				

Locking Element

optional
nickel-plated version
optional full stainless
steel version

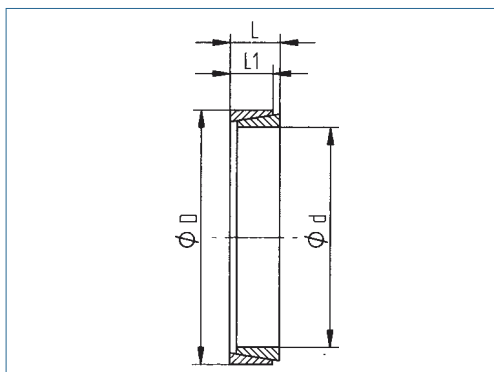

transmittable torque	low
surface pressure on hub	low
self-centering	no
axial movement of the hub during assembly	no
height D/d	flat
overall length	short

Order Code **KBS 50 - 24 x 28**
Type Ød ØD

Recommended finishing tolerances of contact surfaces are: shaft h8 / hub H8

Inner / Outer Ø dxD	Torque T Nm	Dimensions		Surface pressure on		Tension Force FA N	Mass kg
		L mm	L1 mm	Shaft Pw N/mm²	Hub Pn N/mm²		
6 x 9#	2.4	4.5	3.7	115	75	3800	0.0012
7 x 10#	3	4.5	3.7	105	70	3900	0.0014
8 x 11#	4.7	4.5	3.7	120	90	5300	0.0015
9 x 12	7.9	4.5	3.7	140	105	15600	0.0017
10 x 13	9.5	4.5	3.7	135	105	15600	0.0018
12 x 15	11.4	4.5	3.7	115	90	15600	0.0021
13 x 16	13.1	4.5	3.7	110	90	15600	0.0023
14 x 18	22.3	6.3	5.3	115	90	25400	0.0049
15 x 19	24.3	6.3	5.3	110	85	25400	0.0053
16 x 20	27.3	6.3	5.3	105	85	25400	0.0055
17 x 21	29.8	6.3	5.3	105	85	25400	0.0058
18 x 22	32.4	6.3	5.3	100	80	25400	0.0061
19 x 24	49	6.3	5.3	140	110	36000	0.0078
20 x 25	53	6.3	5.3	135	105	36000	0.0082
22 x 26	66	6.3	5.3	135	115	36000	0.0072
24 x 28	73	6.3	5.3	130	110	36000	0.0080
25 x 30	72	6.3	5.3	115	95	36000	0.0100
28 x 32	86	6.3	5.3	115	100	36000	0.0090
30 x 35	91	6.3	5.3	100	85	45000	0.0120
32 x 36	131	6.3	5.3	130	115	54000	0.0100
35 x 40	171	7.0	6.0	125	110	54000	0.0170
36 x 42	169	7.0	6.0	115	100	54000	0.0200
38 x 44	181	7.0	6.0	110	95	66000	0.0210
40 x 45	231	8.0	6.6	115	105	66000	0.0230
42 x 48	235	8.0	6.6	110	95	99000	0.0280
45 x 52	353	10.0	8.6	105	95	132000	0.0420
48 x 55	572	10.0	8.6	155	135	132000	0.0450
50 x 57	602	10.0	8.6	150	130	132000	0.0470
55 x 62	670	10.0	8.6	140	125	132000	0.0500
56 x 64	790	12.0	10.4	130	115	157200	0.0670

automatically slit

Locking Element

optional
nickel-plated version
optional full stainless
steel version

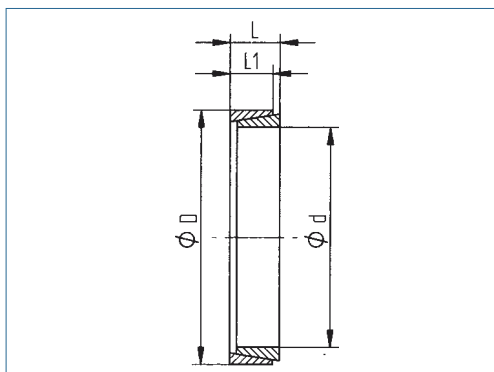

transmittable torque	low
surface pressure on hub	low
self-centering	no
axial movement of the hub during assembly	no
height D/d	flat
overall length	short

Order Code	KBS 50 - 24 x 28
	Type Ød ØD

Recommended finishing tolerances of contact surfaces are: shaft h8 / hub H8

Inner / Outer Ø dxD	Torque T Nm	Dimensions		Surface pressure on		Tension Force FA N	Mass kg
		L mm	L1 mm	Shaft Pw N/mm ²	Hub Pn N/mm ²		
60 x 68	860	12	10.4	125	110	157200	0.072
63 x 71	910	12	10.4	120	105	157200	0.077
65 x 73	950	12	10.4	115	100	157200	0.079
70 x 79	1380	14	12.2	125	110	209600	0.110
75 x 84	1450	14	12.2	115	100	209600	0.130
80 x 91	2200	17	15.0	125	105	290000	0.190
85 x 96	2400	17	15.0	120	106	312000	0.200
90 x 101	2750	17	15.0	120	107	325000	0.200
95 x 106	3060	17	15.0	120	108	339000	0.200
100 x 114	4230	21	18.7	120	105	452000	0.400
110 x 124	5120	21	18.7	120	106	492000	0.400
120 x 134	6090	21	18.7	120	107	527000	0.500
130 x 148	9670	28	25.3	120	105	783300	0.800
140 x 158	11200	28	25.3	120	106	830200	0.900
150 x 168	12900	28	25.3	120	107	877800	1.000
160 x 178	14700	28	25.3	120	108	926000	1.000
170 x 191	19600	33	30.0	120	107	1180000	1.500
180 x 201	22000	33	30.0	120	107	1234700	1.600
190 x 211	24500	33	30.0	120	108	1295300	1.700
200 x 224	31500	38	34.8	120	107	1591700	2.300
210 x 234	34700	38	34.8	120	108	1655900	2.500
220 x 244	38100	38	34.8	120	108	1720600	2.600

Rigid Shaft Coupling

optional
nickel-plated version
optional full stainless
steel version

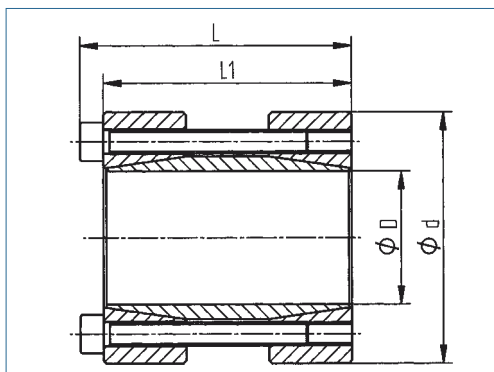

transmittable torque	high
self-centering	yes
axial movement of the hub during assembly	no
height D/d	medium
overall length	medium

Order Code

KBS 95 - 20 x 50

Type

Ød

ØD

Recommended finishing tolerances of contact surfaces are: shaft h8 / hub H8

Inner / Outer Ø dxD	Torque T Nm	Dimensions		Screws			Mass kg
		L mm	L1 mm	No.	ISO 4762	TA Nm	
15 x 45	158	56	50	4	M6x40	17	0.41
16 x 50	168	56	50	4	M6x40	17	0.49
17 x 50	200	56	50	4	M6x40	17	0.49
18 x 50	220	56	50	4	M6x40	17	0.48
19 x 50	230	56	50	4	M6x40	17	0.46
20 x 50	240	56	50	4	M6x40	17	0.44
24 x 55	290	66	60	4	M6x40	17	0.64
25 x 55	450	66	60	6	M6x50	17	0.65
28 x 60	510	66	60	6	M6x50	17	0.72
30 x 60	550	66	60	6	M6x50	17	0.84
32 x 63	580	66	60	6	M6x50	17	1.10
35 x 75	790	83	75	4	M8x60	41	1.40
38 x 75	850	83	75	4	M8x60	41	1.80
40 x 75	900	83	75	4	M8x60	41	1.80
42 x 78	950	83	75	4	M8x60	41	1.90
45 x 85	1520	93	85	6	M8x70	41	1.90
48 x 90	1620	93	85	6	M8x70	41	1.95
50 x 90	1690	93	85	6	M8x70	41	2.00
55 x 94	2470	93	85	8	M8x70	41	2.20
60 x 100	2710	93	85	8	M8x70	41	2.35
65 x 105	2930	93	85	8	M8x70	41	3.65
70 x 115	3770	110	100	6	M10x80	83	3.90
75 x 125	4030	110	100	6	M10x80	83	4.50
80 x 125	4300	110	100	6	M10x80	83	4.30

Please contact us for our catalogues
for **SERVO COUPLINGS** and
SAFETY COUPLINGS

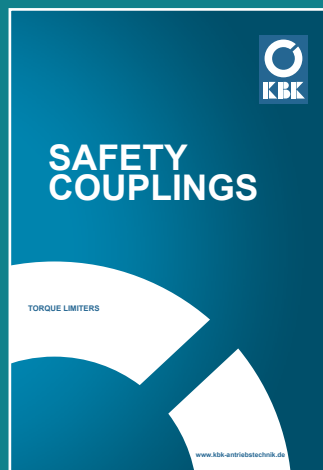

KBK Antriebstechnik GmbH

Unterlandstraße 46

63911 Klingenberg am Main

Germany

Phone: +49 9372 94061-0

Fax: +49 9372 94061-29

info@kbk-antriebstechnik.de

www.kbk-antriebstechnik.de

The details contained in this catalogue are product descriptions based on our knowledge and experience. We reserve the right to make alterations at any time and cannot be responsible for any omissions or printing errors.

12/2018