



SERVO COUPLINGS

METAL BELLOWS COUPLINGS
SERVO INSERT COUPLINGS
CARDAN COUPLINGS
LINE SHAFTS
RIGID SHAFT COUPLINGS

KBK – The Company

KBK Antriebstechnik GmbH - successful since 2003

Our products are based on the experience of more than 30 years in developing and producing shaft-hub-connections and backlash-free couplings combined with professional advice, service and professional competence. Our sophisticated modular design forms the basis for top quality products at reasonable prices. It enables us to produce almost all elastomer-, metal bellows-, safety couplings and line shafts as well as locking devices from the standard range within two hours, provide them with customized bores and organize a direct delivery to you by courier. Our traffic-favourable position on the edge of the Rhine-Main area simplifies the delivery to our customers all over the world. Benefit from our strenghts and our strong motivation to satisfy all our business-partners and safe time and money for your company.

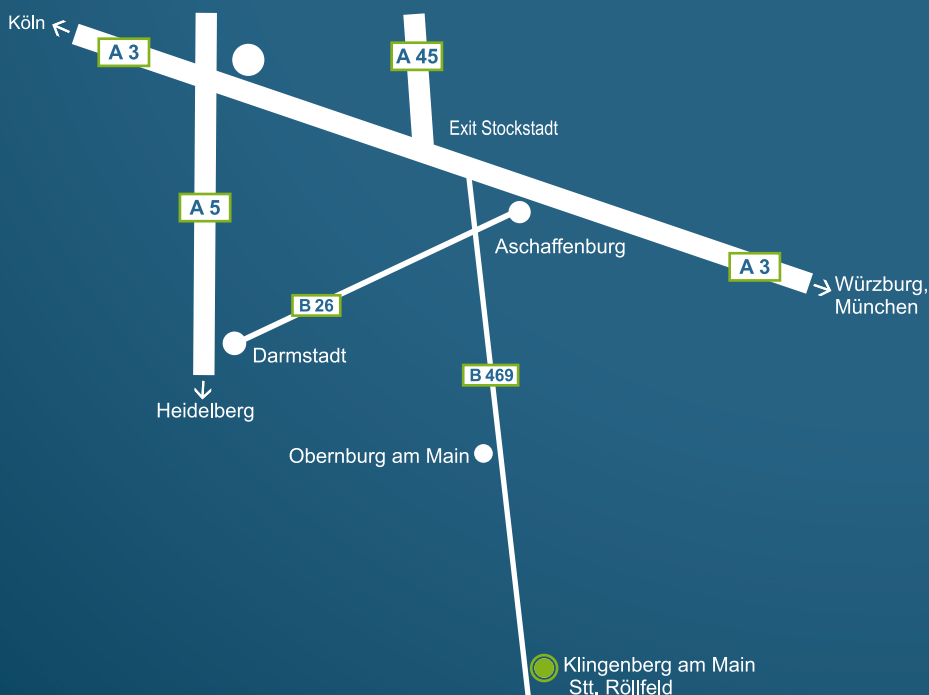

Contents

Miniature Metal Bellows Couplings	Page 5
KB1 - with set screws 0,05-10 Nm	Page 6
KB1P - axial pluggable, with set screws 0,5-10 Nm	Page 7
KB2 - with collet clamps 0,1-10 Nm	Page 8
KB2H - with split hubs 0,5-10 Nm	Page 9
KB2P - axial pluggable, with collet clamps 0,5-10 Nm	Page 10
KB2VA - with stainless steel collet clamps 0,1-10 Nm	Page 11
KB3 - with expanding clamps 0,5-10 Nm	Page 12
KB3P - axial pluggable, with expanding clamps 0,5-10 Nm	Page 13
Metal Bellows Couplings	Page 14 / 15
KB4 - with collet clamps 18-1400 Nm	Page 16
KB4AL - with collet clamps 80-500 Nm	Page 17
KB4C - with collet clamps, compact 18-500 Nm	Page 18
KB4F - with adapting flange 18-1400 Nm	Page 19
KB4H - with split hubs 18-1400 Nm	Page 20
KB4HC - with split hubs 18-500 Nm	Page 21
KB4K - with collet clamps 40-1500 Nm	Page 22
KB4P - axial pluggable 18-500 Nm	Page 23
KB4VA - with stainless steel collet clamps 18-500 Nm	Page 24
KB5 - with inner conical hubs 18-5000 Nm	Page 25
KB6 - with outer conical hubs 18 bis 5000 Nm	Page 26
KB6P - axial pluggable, with outer conical hubs 18-500 Nm	Page 27
KB7 - for flange mounting 18-5000 Nm	Page 28
KB8 - with expanding clamps 18-300 Nm	Page 29
KB8P - axial pluggable, with expanding clamps 18-300 Nm	Page 30

Contents

Servo Insert Couplings	Page 31
KBE1 - with set screws sizes 5-48	Page 32
KBE2 - with collet clamps sizes 5-19	Page 33
KBE2 - with collet clamps sizes 24-48	Page 34
KBE2C - with collet clamps, compact sizes 7-48	Page 35
KBE2H - with split hubs sizes 14-48	Page 36
KBE2HC - with split hubs sizes 14-48	Page 37
KBE2D - doublecardanic with collet clamps sizes 7-38	Page 38
KBE3 - with outer conical hubs sizes 14-48	Page 39
KBE3C - with outer conical hubs, compact sizes 14-48	Page 40
KBE4 - with expanding clamps sizes 14-38	Page 41
Spider Elements for Couplings series KBE	Page 42
Line Shafts, Cardan - and Rigid Shaft Couplings	Page 43
KBGK - linear coupling with threads 200-13000 N	Page 44
KBGK-T - cardan coupling with collet clamps 3-580 Nm	Page 45
DRE - split hubs and servo inserts	Page 46
DRB - split hubs and metal bellows	Page 47
KBST - rigid shaft couplings, single slit	Page 48
KBST-VA - rigid shaft couplings, single slit, stainless steel	Page 49
KBST-G - rigid shaft couplings, split	Page 50
KBST-G-VA - rigid shaft couplings, split, stainless steel	Page 51

MINIATURE COUPLINGS

KB1 | 05 ~ 100

Miniature Metal Bellows Coupling
with set screws



P. 6

KB1P | 5 ~ 100

Miniature Metal Bellows Coupling
axial pluggable, with set screws



P. 7

KB2 | 1 ~ 100

Miniature Metal Bellows Coupling
with collet clamps



P. 8

KB2H | 5 ~ 100

Miniature Metal Bellows Coupling
with split hubs



P. 9

KB2P | 5 ~ 100

Miniature Metal Bellows Coupling
axial pluggable, with collet clamps



P. 10

KB2VA | 1 ~ 100

Miniature Metal Bellows Coupling
with stainless steel collet clamps



P. 11

KB3 | 5 ~ 100

Miniature Metal Bellows Coupling
with expanding clamps



P. 12

KB3P | 5 ~ 100

Miniature Metal Bellows Coupling
axial pluggable, with expanding clamps



P. 13

Miniature Metal Bellows Coupling

with set screws

optional
laserwelded
optional full stainless
steel version

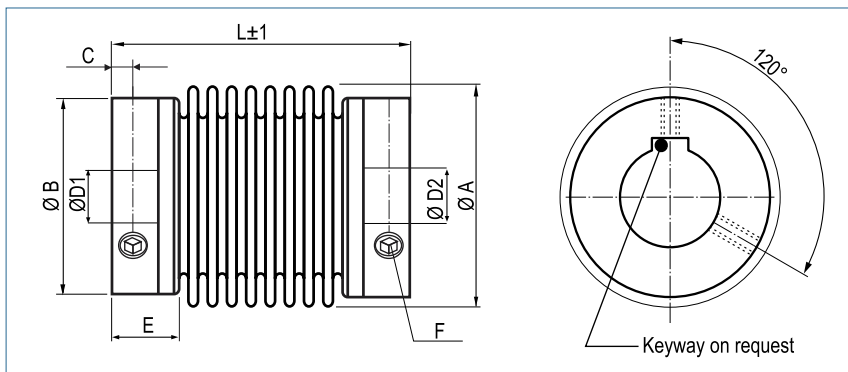

Order Code

KB1 / 45 - 40 - 10 - 18 - (S)

Type / Size

Length
L

ØD1
(H7)

ØD2
(H7)

Options

Size	Torque TKN (Nm)	Dimensions (mm)							Technical Data							
		L	Ø A	D1/D2	Ø B	C	E	F	Mass (g)	Moment of Inertia J (g cm ²)	Spring Stiffness			Misalignment		
		Length	Outer Ø	Bore Sizes (H7) min-max	Hub Ø	Hub- length	Screw (ISO4029) TA (Nm)	torsional CT (Nm/rad)			radial CR (N/mm)	axial CA (N/mm)	radial ΔKr (mm)	axial ΔKa (mm)	angular ΔKw (°)	
05	0.05	14	6.5	1-3	6.5	1.5	4	1x M2 0.35	1	0.1	50	6	9	0.1	0.4	1
1	0.1	23	10	1-4	10	2	6	1x M3 0.5	3	0.45	65	10	14	0.12	0.2	1.2
5	0.5	19	15	3-8	13.5	2	6	1x M3 0.5	4	1.3	260	43	13	0.1	0.2	1
		4.5							1.5	200	18	10	0.15	0.3	1.5	
		5							1.6	160	9	8	0.2	0.4	2	
10	1	21	15	3-8	13.5	2	6	1x M3 0.5	5.5	1.8	510	74	27	0.1	0.2	1
		6							2	380	31	20	0.15	0.3	1.5	
		7							2.3	310	16	16	0.2	0.4	2	
15	1.5	26	19	3-12	19	3	8	2x M4	10	6	750	59	15	0.1	0.3	1.5
		30		8#				1.5	12	7.4	700	20	9	0.15	0.4	2
20	2	22	24	3-14	21.5	3	6	2x M4	11	9.2	1500	67	12	0.15	0.3	1.5
		13		12.6				1300	21	11	0.2	0.4	1.5			
		15		13.5				1050	11	9	0.25	0.5	2			
		32		10#				1.5	15	13.5	1050	11	9	0.25	0.5	2
45	4.5	40	32	6-19	29	4	12	2x M6	44	68	6500	168	32	0.1	0.3	1.5
		3		50				79	4200	41	20	0.2	0.5	2		
100	10	45	40	6-24	36	4	12	2x M6	60	150	8100	120	27	0.15	0.4	1.5
		3		79				210	6800	29	17	0.3	0.6	2		

Speed	max. 15000 min ⁻¹
Material	bellows - stainless steel, size 05: bronze hub - aluminium
Hub	bore tolerance: H7
Temperature Range	-30 °C ~ 120 °C
Keyway	optional acc. DIN 6885 biggest bore with keyway marked with a #

Miniature Metal Bellows Coupling

axial pluggable, with set screws

optional
laserwelded
optional full stainless
steel version

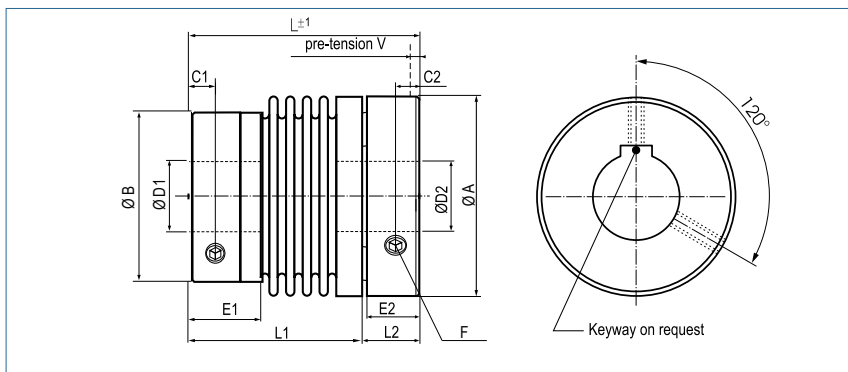

Order Code

KB1P / 15 - 32 - 5 - 10 - D - (S)

Type / Size Length L ØD1 (H7) ØD2 (H7) Plug System Options

Size	Torque TKN (Nm)	Dimensions (mm)								Technical Data							
		L	Ø A	Ø B	D1	D2	C1	C2	F	Mass (g)	Moment of Inertia J (g cm ²)	Spring Stiffness			Misalignment		
		Length	Plug Hub Ø	Set Screw Ø	Bore Size (H7) min-max	Bore Size (H7) min-max			Screw (ISO4029) TA (Nm)			torsional CT (Nm/rad)	radial CR (N/mm)	axial CA (N/mm)	radial Δ Kr (mm)	axial Δ Ka (mm)	angular Δ Kw (°)
5	0.5	22	15.5	13.5	3-8	3-8	2	2	1xM3	5.9	1.9	260	43	13	0.1	0.2	1
		26								6.6	2.2	200	18	10	0.15	0.3	1.5
		30								0.5	7.4	2.4	160	9	8	0.2	0.4
10	1	24	15.5	13.5	3-8	3-8	2	2	1xM3	8.1	2.7	510	74	27	0.1	0.2	1
		28								8.8	2.9	380	31	20	0.15	0.3	1.5
		32								0.5	10.3	3.4	310	16	16	0.2	0.4
15	1.5	28	20	19	3-12	3-10	3	2.5	2xM4	14.7	8.8	750	59	15	0.1	0.3	1.5
		32			8#	7#				1.5	17.6	10.9	700	20	9	0.15	0.4
20	2	27	25	21.5	3-14	3-14	3	2.5	2xM4	16.2	13.5	1500	67	12	0.15	0.3	1.5
		37			10#	10#				1.5	22	19.9	1050	11	9	0.25	0.5
45	4.5	44	32.5	29	6-19	6-16	4	4	2xM6	64.7	100	6500	168	32	0.1	0.3	1.5
		52			13#	11#				3	73.5	116	4200	41	20	0.2	0.5
100	10	50	40.5	36	6-24	6-25	4	4	2xM6	88.2	220.5	8100	120	27	0.15	0.4	1.5
		60			17#	18#				3	116.1	308.7	6800	29	17	0.3	0.6

+ **Speed** max. 15000 min⁻¹

Material bellows - stainless steel
hub - aluminium

Hub bore tolerance: H7

Temperature Range -30 °C ~ 120 °C

Keyway optional acc. DIN 6885
biggest bore with keyway marked with a #

Size	Dimensions (mm)					
	E1	E2	L1	L2	L3	V
5	6	4	17	5	9	0.5
			21			
			25			
10	6	4	19	5	9	0.5
			23			
			27			
15	8	5	22	6	11	0.5
			26			
20	6	5	21	6	11	0.5
			27			
			31			
45	12	8	35	9	16	0.5
			43			
100	12	8	41	9	17	1
			51			

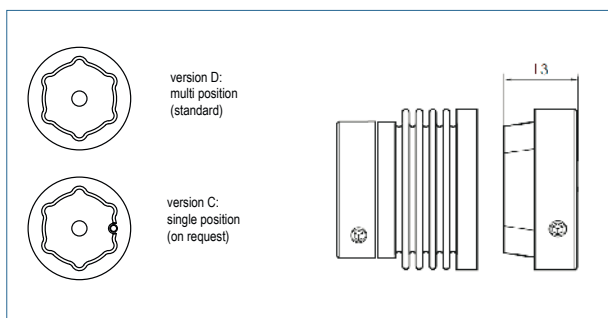

Miniature Metal Bellows Coupling

with collet clamps

optional
laserwelded
optional full stainless
steel version

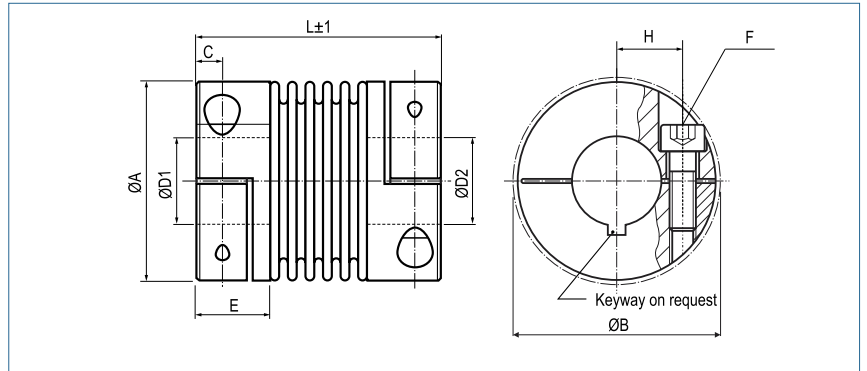

Order Code

KB2 / 45 - 50 - 10 - 16 - (S)

Type / Size Length L ØD1 (H7) ØD2 (H7) Options

Size	Torque TKN (Nm)	Dimensions (mm)								Technical Data							
		L	Ø A	D1/D2	H	C	Ø B	E	F	Mass (g)	Moment of Inertia J (g cm ²)	Spring Stiffness			Misalignment		
		Length	Outer Ø	Bore Sizes (H7) min-max				Hub-length	Screw (ISO4762) TA (Nm)			torsional CT (Nm/rad)	radial CR (N/mm)	axial CA (N/mm)	radial ΔKr (mm)	axial ΔKa (mm)	angular ΔKw (°)
1	0.1	25	10	1-4	3.4	2	11	7	M1.6	3	0.5	65	10	14	0.12	0.2	1.2
		0.1															
5	0.5	21	15.5	3-8	5.2	2.5	17.5	7	M2	7.5	2.7	260	43	13	0.1	0.2	1
		25		8#					7.8	2.8	200	18	10	0.15	0.3	1.5	
		28		0.43					8.2	3	160	9	8	0.2	0.4	2	
10	1	23	15.5	3-8	5.2	2.5	17.5	7	M2	9	3.1	510	74	27	0.1	0.2	1
		26		8#					9.3	3.4	380	31	20	0.15	0.3	1.5	
		31		0.43					10	3.7	310	16	16	0.2	0.4	2	
15	1.5	26	20	3-10	7	3	21	8,5	M2.5	13	8	750	59	15	0.1	0.3	1.5
		31		10#					0.85	15	9.3	700	20	9	0.15	0.4	2
20	2	32	25	3-14	9	3.5	27	11	M3	29	24	1500	67	12	0.15	0.3	1.5
		38		14#					32	27	1300	21	11	0.2	0.4	1.5	
		42		2					33	29	1050	11	9	0.25	0.5	2	
45	4.5	41	32.5	6-18	12	5	34	13	M4	61	100	6500	168	32	0.1	0.3	1.5
		50		18#					67	112	4200	41	20	0.2	0.5	2	
100	10	47	40.5	6-25	15.5	5	41.5	13,5	M4	86	233	8100	120	27	0.15	0.4	1.5
		57		25#					4.5	106	290	6800	29	17	0.3	0.6	2

Speed	max. 15000 min ⁻¹
Material	bellows - stainless steel hub - aluminium
Hub	bore tolerance: H7
Temperature Range	-30 °C ~ 120 °C
Keyway	optional acc. DIN 6885 biggest bore marked with a #

Miniature Metal Bellows Coupling

with split hubs

optional
laserwelded
optional full stainless
steel version

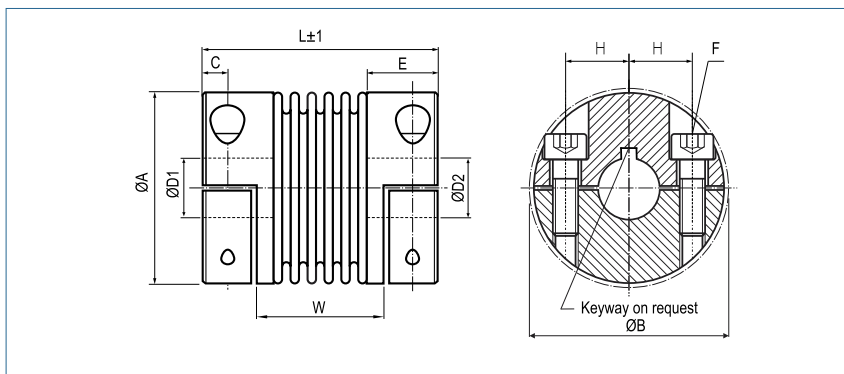

Order Code

KB2H / 45 - 50 - 10 - 16 - (S)

Type / Size

Length
L

ØD1
(H7)

ØD2
(H7)

Options

Size	Torque TKN (Nm)	Dimensions (mm)									Technical Data							
		L	Ø A	D1/D2	H	C	ØB	E	W	F	Mass (g)	Moment of Inertia J (g cm ²)	Spring Stiffness			Misalignment		
		Length	Outer Ø	Bore Sizes (H7) min~max				Hub- length		Screw (ISO4762) TA (Nm)			torsional CT (Nm/rad)	radial CR (N/mm)	axial CA (N/mm)	radial ΔKr (mm)	axial ΔKa (mm)	angular ΔKw (°)
5	0.5	21	15.5	3-8	5.2	2.5	17.5	7	12	M2	7.5	2.7	260	43	13	0.1	0.2	1
		16							0.43	7.8	2.8	200	18	10	0.15	0.3	1.5	
		19								8.2	3	160	9	8	0.2	0.4	2	
10	1	23	15.5	3-8	5.2	2.5	17.5	7	14	M2	9	3.1	510	74	27	0.1	0.2	1
		17							0.43	9.3	3.4	380	31	20	0.15	0.3	1.5	
		22		10						3.7	310	16	16	0.2	0.4	2		
15	1.5	26	20	3-10	7	3	21	8,5	14.4	M2.5	13	8	750	59	15	0.1	0.3	1.5
		31		10#					19.4	0.85	15	9.3	700	20	9	0.15	0.4	2
20	2	32	25	3-14	9	3.5	27	11	18.4	M3	29	24	1500	67	12	0.15	0.3	1.5
		24.4							2	32	27	1300	21	11	0.2	0.4	1.5	
		28.4		33						29	1050	11	9	0.25	0.5	2		
45	4.5	41	32.5	6-18	12	5	34	13	24	M4	61	100	6500	168	32	0.1	0.3	1.5
		33		3.5					67	112	4200	41	20	0.2	0.5	2		
100	10	47	40.5	6-25	15.5	5	41.5	13,5	29	M4	86	233	8100	120	27	0.15	0.4	1.5
		39		4.5					106	290	6800	29	17	0.3	0.6	2		



Speed	max. 15000 min ⁻¹
Material	bellows - stainless steel hub - aluminium
Hub	bore tolerance: H7
Temperature Range	-30 °C ~ 120 °C
Keyway	optional acc. DIN 6885 biggest bore marked with a #

Miniature Metal Bellows Coupling

axial pluggable, with collet clamps

optional
laserwelded
optional full stainless
steel version

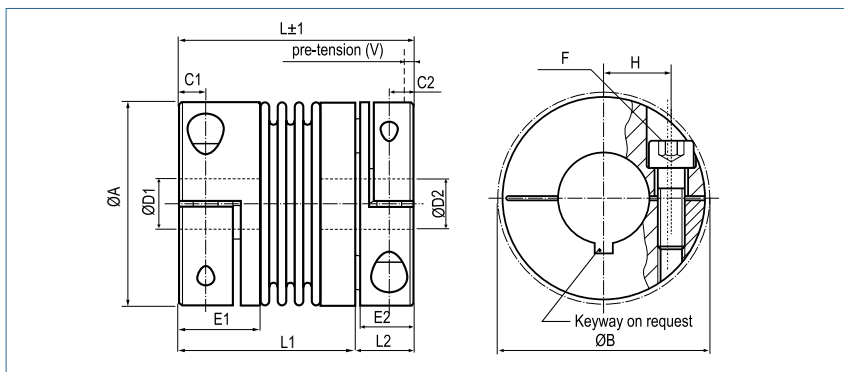

Order Code

KB2P / 15 - 30 - 5 - 10 - D - (S)

Type / Size Length L ØD1 (H7) ØD2 (H7) Plug System Options

Size	Torque TKN (Nm)	Dimensions (mm)									Technical Data							
		L	Ø A	Ø B	D1	D2	H	C1	C2	F	Mass (g)	Moment of Inertia J (g cm ²)	Spring Stiffness			Misalignment		
		Length	Outer Ø		Bore Size (H7) min-max	Bore Size (H7) min-max				Screw (ISO4762) TA (Nm)			torsional CT (Nm/rad)	radial CR (N/mm)	axial CA (N/mm)	radial Δ Kr (mm)	axial Δ Ka (mm)	angular Δ Kw (°)
5	0.5	25	15.5	17.5	3-8	3-8	5.2	2.5	2.5	M2	8.7	3.1	260	43	13	0.1	0.2	1
		29			8#					9.1	3.3	200	18	10	0.15	0.3	1.5	
		32			0.43					9.6	3.5	160	9	8	0.2	0.4	2	
10	1	27	15.5	17.5	3-8	3-8	5.2	2.5	2.5	M2	10.5	3.6	510	74	27	0.1	0.2	1
		30			8#					10.8	3.9	380	31	20	0.15	0.3	1.5	
		32			0.43					11.7	4.3	310	16	16	0.2	0.4	2	
15	1.5	30	20	21	3-10	3-10	7	3	3	M2.5	15.2	9.3	750	59	15	0.1	0.3	1.5
		35			10#	7#				0.85	17.5	10.8	700	20	9	0.15	0.4	2
20	2	37	25	27	3-14	3-14	9	3.5	3.5	M3	33.8	27.8	1500	67	12	0.15	0.3	1.5
		43			14#	10#				2	38.5	33.6	1050	11	9	0.25	0.5	2
		47			18#	11#				3.5	78	129.9	4200	41	20	0.2	0.5	2
45	4.5	49	32.5	34	6-18	6-16	12	5	5	M4	71	116	6500	168	32	0.1	0.3	1.5
		58			25#	18#				4.5	123.5	336.4	6800	29	17	0.3	0.6	2
100	10	56	40.5	41.5	6-25	6-25	15.5	5	5	M4	100	270.3	8100	120	27	0.15	0.4	1.5
		66			25#	18#				4.5	123.5	336.4	6800	29	17	0.3	0.6	2

Speed	max. 15000 min ⁻¹
Material	bellows - stainless steel hub - aluminium
Hub	bore tolerance: H7
Temperature Range	-30 °C ~ 120 °C
Keyway	optional acc. DIN 6885 biggest bore marked with a #

Size	Dimensions (mm)					
	E1	E2	L1	L2	L3	V
5	7	6	18	7	11	0.5
			22			
			25			
10	7	6	20	7	11	0.5
			23			
			25			
15	8.5	6.5	22.5	7.5	12.5	0.5
			27.5			
20	11	10	26	11	16	0.5
			32			
			36			
45	13	12	36	14	20	0.5
			45			
100	13.5	12	43	14	21	1
			53			

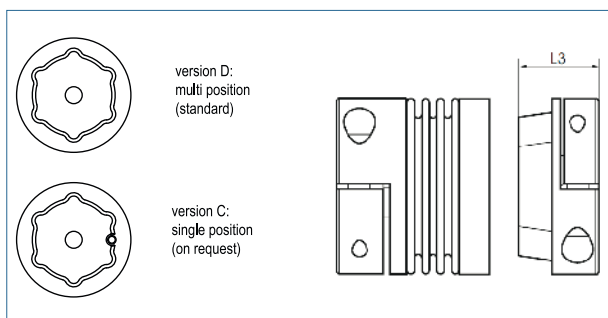

Miniature Metal Bellows Coupling

with stainless steel collet clamps

optional
laserwelded

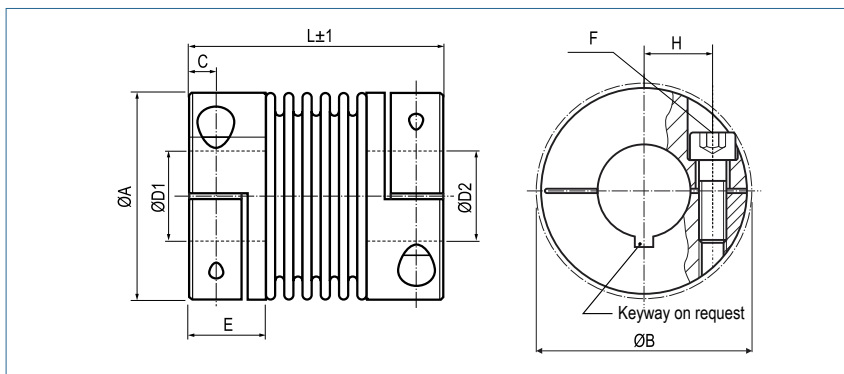

Order Code

KB2 / 45 - 50 - 10 - 16 - VA/VAW

Type / Size

Length
L

ØD1
(H7)

ØD2
(H7)

stainless steel
glued / laserwelded

Size	Torque TKN (Nm)	Dimensions (mm)								Technical Data							
		L	Ø A	D1/D2	H	C	Ø B	E	F	Mass (g)	Moment of Inertia J (g cm ²)	Spring Stiffness			Misalignment		
		Length	Outer Ø	Bore Sizes (H7) min-max			Hub- length	Screw (ISO4762) TA (Nm)	torsional CT (Nm/rad)			radial CR (N/mm)	axial CA (N/mm)	radial ΔKr (mm)	axial ΔKa (mm)	angular ΔKw (°)	
1	0.1	25	10	1-4	3.4	2	11	7	M1.6 0.1	7	1	65	10	14	0.12	0.2	1.2
5	0.5	21	15.5	3-8	5.2	2.5	17.5	7	M2	18	5.9	260	43	13	0.1	0.2	1
		25		8#					18	6.2	200	18	10	0.15	0.3	1.5	
		28							19	6.6	160	9	8	0.2	0.4	2	
10	1	23	15.5	3-8	5.2	2.5	17.5	7	M2	19	6.8	510	74	27	0.1	0.2	1
		26		8#					20	7.5	380	31	20	0.15	0.3	1.5	
		31							21	8.1	310	16	16	0.2	0.4	2	
15	1.5	26	20	3-10	7	3	21	8,5	M2.5	36	18	750	59	15	0.1	0.3	1.5
		31		10#					38	21	700	20	9	0.15	0.4	2	
20	2	32	25	3-14	9	3.5	27	11	M3	70	53	1500	67	12	0.15	0.3	1.5
		38		14#					73	60	1300	21	11	0.2	0.4	1.5	
		42							75	64	1050	11	9	0.25	0.5	2	
45	4.5	41	32.5	6-18	11.5	5	34	13	M4	133	220	6500	168	32	0.1	0.3	1.5
		50		18#					139	246	4200	41	20	0.2	0.5	2	
100	10	47	40.5	6-25	15.5	5	41.5	13,5	M4	244	513	8100	120	27	0.15	0.4	1.5
		57		25#					261	638	6800	29	17	0.3	0.6	2	



Speed	max. 15000 min ⁻¹
Material	bellows - stainless steel hub - stainless Steel
Hub	bore tolerance: H7
Temperature Range	VA -30 °C ~ 120 °C (glued) VAW -30 °C ~ 250 °C (laserwelded)
Keyway	optional acc. DIN 6885 biggest bore marked with a #

Miniature Metal Bellows Coupling

with expanding clamps

optional
laserwelded
optional full stainless
steel version

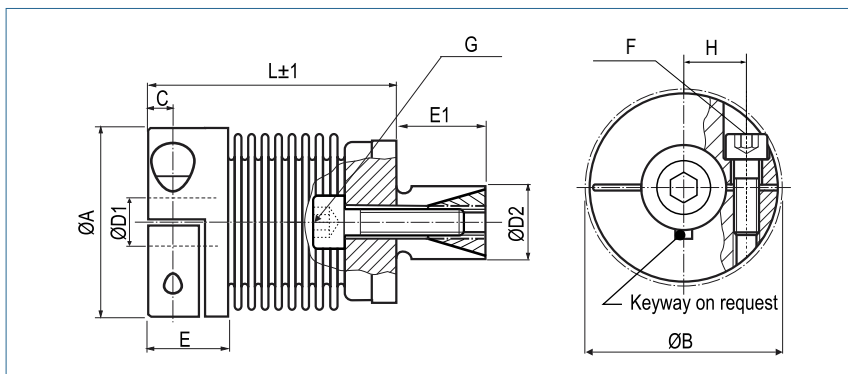

Order Code

KB3 / 45 - 36 - 10 - 18 - (S)

Type / Size

Length
L

ØD1
(H7)

ØD2
(f7)

Options

Size	Torque TKN (Nm)	Dimensions (mm)										Technical Data							
		L	Ø A	D1	D2	Ø B	H	C	E	E1	F/G	Mass (g)	Moment of Inertia J (g cm ²)	Spring Stiffness			Misalignment		
		Length	Outer Ø	Bore Size (H7) min~max	(f7) min~max						Screw (ISO4762) TA (Nm)			torsional CT (Nmrad)	radial CR (N/mm)	axial CA (N/mm)	radial ΔKr (mm)	axial ΔKa (mm)	angular ΔKw (°)
5	0.5	20	15.5	3-8	8-12	17,5	5.2	2.5	7	8	M2/M3	12.8	2.9	260	43	13	0.1	0.2	1
		24		8#							0.3/1	13.2	3.1	200	18	10	0.15	0.3	1.5
		27										13.5	3.2	160	9	8	0.2	0.4	2
10	1	22	15,5	3-8	8-12	17,5	5.2	2.5	7	8	M2/M3	14.1	3.3	510	74	27	0.1	0.2	1
		26		8#							0.3/1	14.6	3.4	380	31	20	0.15	0.3	1.5
		30										15.3	3.6	310	16	16	0.2	0.4	2
15	1.5	25	20	3-10	10-14	21	7	3	8,5	12	M2.5/M4	27.2	11	750	59	15	0.1	0.3	1.5
		29		10#							0.8/3	29.3	12	700	20	9	0.15	0.4	2
20	2	28	25	3-14	10-16	27	9	3.5	11	12	M3/M4	40.1	25	1500	67	12	0.15	0.3	1.5
		34		14#							1/3	43.2	29	1300	21	11	0.2	0.4	1.5
		38										49.1	30	1050	11	9	0.25	0.5	2
45	4.5	36	32.5	6-18	14-20	34	12	5	13	16	M4/M5	86.5	98	6500	168	32	0.1	0.3	1.5
		44		18#							3/5.9	92.9	110	4200	41	20	0.2	0.5	2
100	10	41	40.5	6-25	16-22	41,5	15.5	5	13,5	20	M4/M6	135	235	8100	120	27	0.15	0.4	1.5
		51		25#							3/10	154	292	6800	29	17	0.3	0.6	2

Speed	max. 15000 min ⁻¹
Material	bellows - stainless steel collet clamps - aluminium expanding clamps - steel
Hub	bore tolerance: H7
Temperature Range	-30 °C ~ 120 °C
Keyway	optional acc. DIN 6885 biggest bore marked with a #

Miniature Metal Bellows Coupling

axial pluggable, with expanding clamps

optional
laserwelded
optional full stainless
steel version

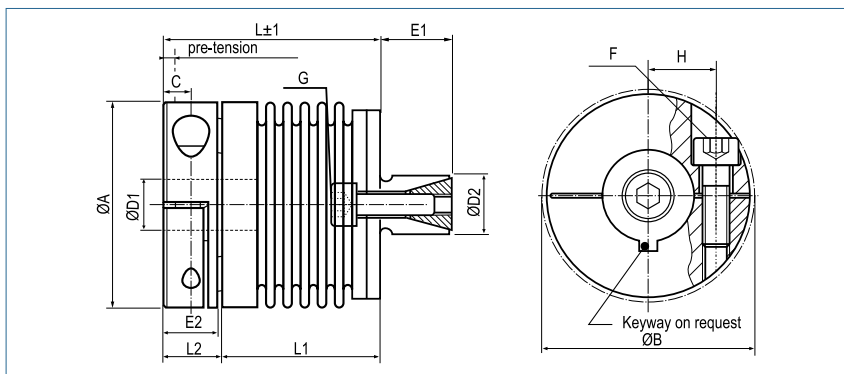

Order Code

KB3P / 15 - 29 - 5 - 10 - D - (S)

Type / Size

Length
L

ØD1
(H7)

ØD2
(f7)

Plug System

Options

Size	Torque TKN (Nm)	Dimensions (mm)								Technical Data							
		L	Ø A	Ø B	D1	D2	H	C	F/G	Mass (g)	Moment of Inertia J (g cm ²)	Spring Stiffness			Misalignment		
		Length	Outer Ø		Bore Size (H7) min~max	(f7) min~max			Screw (ISO4762) TA (Nm)			torsional CT (Nm/rad)	radial CR (N/mm)	axial CA (N/mm)	radial Δ Kr (mm)	axial Δ Ka (mm)	angular Δ Kw (°)
5	0.5	24	15.5	17.5	3-8	8-12	5.2	2.5	M2/M3	14.9	3.4	260	43	13	0.1	0.2	1
		28			8#				15.4	3.6	200	18	10	0.15	0.3	1.5	
		31			0.43/1				15.8	3.7	160	9	8	0.2	0.4	2	
10	1	26	15.5	17.5	3-8	8-12	5.2	2.5	M2/M3	16.4	3.8	510	74	27	0.1	0.2	1
		30			8#				17	4	380	31	20	0.15	0.3	1.5	
		34			0.43/1				17.8	4.2	310	16	16	0.2	0.4	2	
15	1.5	29	20	21	3-10	10-14	7	3	M2.5/M4	31.7	12.8	750	59	15	0.1	0.3	1.5
		33			10#				34.1	14	700	20	9	0.15	0.4	2	
20	2	33	25	27	3-14	10-16	9	3.5	M3/M4	46.7	29.1	1500	67	12	0.15	0.3	1.5
		39			14#				50.3	33.8	1300	21	11	0.2	0.4	1.5	
		43			2/3				57.2	34.9	1050	11	9	0.25	0.5	2	
45	4.5	43	32.5	34	6-18	14-20	12	5	M4/M5	100.7	114.1	6500	168	32	0.1	0.3	1.5
		51			18#				108.1	128	4200	41	20	0.2	0.5	2	
100	10	49	40.5	41.5	6-25	16-22	15.5	5	M4/M6	157.1	273.5	8100	120	27	0.15	0.4	1.5
		59			25#				179.3	339.9	6800	29	17	0.3	0.6	2	



Speed	max. 15000 min ⁻¹
Material	bellows - stainless steel collet clamps - aluminium expanding clamps - steel
Hub	bore tolerance: H7
Temperature Range	-30 °C ~ 120 °C
Keyway	optional acc. DIN 6885 biggest bore marked with a #

Size	Dimensions (mm)					
	E1	E2	L1	L2	L3	V
5	8	6	17	7	11	0.5
			21			
			24			
10	8	6	19	7	11	0.5
			23			
			27			
15	12	6.5	21.5	7.5	12.5	0.5
			25.5			
20	12	10	22	11	16	0.5
			28			
			32			
45	16	12	30	13	20	0.5
			38			
100	20	12	36	13	21	1
			46			

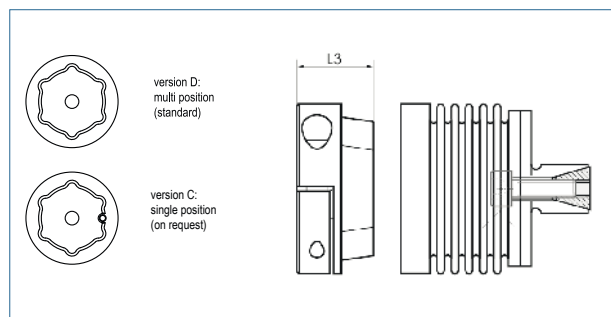

METAL BELLOWS COUPLINGS

KB4 | 18 ~ 1400

Metal Bellows Coupling
with collet clamps



P. 16

KB4AL | 80 ~ 500

Metal Bellows Coupling
with collet clamps



P. 17

KB4C | 18 ~ 500

Metal Bellows Coupling
with collet clamps, compact



P. 18

KB4F | 18 ~ 1400

Metal Bellows Coupling
with adapting flange



P. 19

KB4H | 18 ~ 1400

Metal Bellows Coupling
with split hubs



P. 20

KB4HC | 18 ~ 500

Metal Bellows Coupling
with split hubs



P. 21

KB4K | 40 ~ 1500

Metal Bellows Coupling
with collet clamps



P. 22

KB4P | 18 ~ 500

Metal Bellows Coupling
axial pluggable



P. 23

KB4VA | 18 ~ 500

Metal Bellows Coupling
with stainless steel collet clamps



P. 24

KB5 | 18 ~ 5000

Metal Bellows Coupling
with inner conical hubs



P. 25

KB6 | 18 ~ 5000

Metal Bellows Coupling
with outer conical hubs



P. 26

KB6P | 18 ~ 500

Metal Bellows Coupling
axial pluggable, with outer conical hubs



P. 27

METAL BELLOWS COUPLINGS

KB7 | 18 ~ 5000

Metal Bellows Coupling
for flange mounting



P. 28

KB8 | 18 ~ 300

Metal Bellows Coupling
with expanding clamps



P. 29

KB8P | 18 ~ 300

Metal Bellows Coupling
axial pluggable, with expanding clamps



P. 30

Metal Bellows Coupling

with collet clamps

optional
laserwelded
optional full stainless
steel version

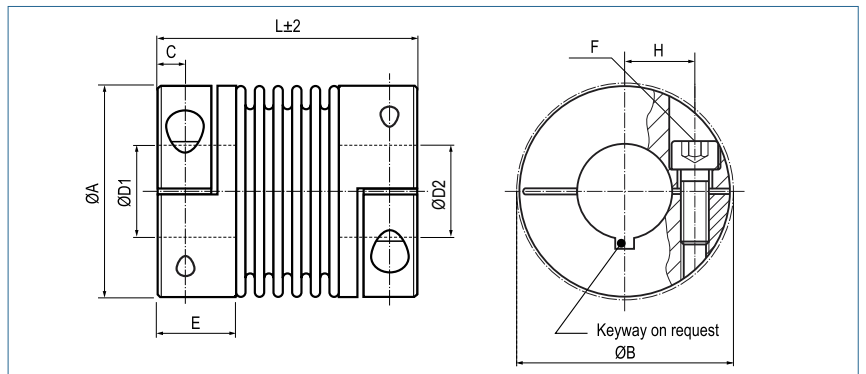

Order Code

KB4 / 60 - 89 - 12 - 32 - (S)

Type / Size

Length
L

ØD1
(H7)

ØD2
(H7)

Options

Size	Torque TKN (Nm)	Dimensions (mm)								Technical Data								
		L	Ø A	D1/D2	H	C	E	B	F	Mass (kg)	Moment of Inertia J (g m ²)	Spring Stiffness			Misalignment			max speed min-1
		Length	Outer Ø	Bore Sizes (H7) min-max					Screw (ISO4762) TA (Nm)			torsional CT 10 ³ (Nm/rad)	radial CR (N/mm)	axial CA (N/mm)	radial ΔKr (mm)	axial ΔKa (mm)	angular ΔKw (°)	
18	18	63	45	10-25.4	17	5.5	19.5	47.4	M5	0.1	0.04	20	205	50	0.2	0.5	1.5	12800
		71							8	0.15	0.05	15	82	36	0.25	0.5	2	12800
30	30	65	56	10-32	20	7.5	24.5	56.4	M6	0.3	0.15	38	720	50	0.15	0.6	1.5	10300
		73		15					0.32	0.16	28	225	28	0.25	1	2	10300	
60	60	79	66	12-35	23	10	29	66	M8	0.5	0.33	75	1150	90	0.15	0.6	1.5	8700
		89							40	0.6	0.36	50	340	50	0.25	1	2	8700
80	80	91	82	14-44	28	11	33.5	82.9	M10	2.3	2.3	128	1200	80	0.2	0.5	1.5	6900
		102							84	2.4	2.4	75	400	50	0.25	0.8	2	6900
150	150	91	82	19-44	28	11	33.5	82.9	M10	2.3	2.5	155	2020	145	0.2	0.5	1.5	6900
		102							84	2.4	2.6	105	595	85	0.25	0.8	2	6900
200	200	101	90	22-47	31	13	38	90.8	M12	2.6	3.3	175	2500	145	0.2	0.5	1.5	6400
		113							125	2.7	3.5	120	460	82	0.25	0.8	2	6400
300	300	105	110	30-60	40	13	38	110	M12	4.3	7.6	502	6300	280	0.2	0.5	1.5	6000
		116							145	4.4	7.8	285	1400	145	0.25	0.8	2	6000
500	500	112	122	35-70	42	15	42	122	M12	5.5	13.5	690	7790	100	0.2	0.5	1.5	5000
		123							145	5.6	13.7	320	970	85	0.25	1	2	5000
800	800	168	157	40-80	55	22.5	55	170.3	2xM20 400	14.3	56.9	1270	700	275	0.2	0.8	1.8	5000
1400	1400	168	157	50-80	55	22.5	55	170.3	2xM20 470	14.8	57.7	1270	700	275	0.2	0.8	1.8	5000

Material	bellows - stainless steel hub -size 18 - 60: aluminium hub - from size 80: steel
Hub	bore tolerance: H7
Temperature Range	-30 °C ~ 120 °C size 800/1400: -30 °C ~ 250 °C
Keyway	optional acc. DIN 6885 biggest bore marked with a #

optional
laserwelded
optional full stainless
steel version

Metal Bellows Coupling in aluminum

with collet clamps

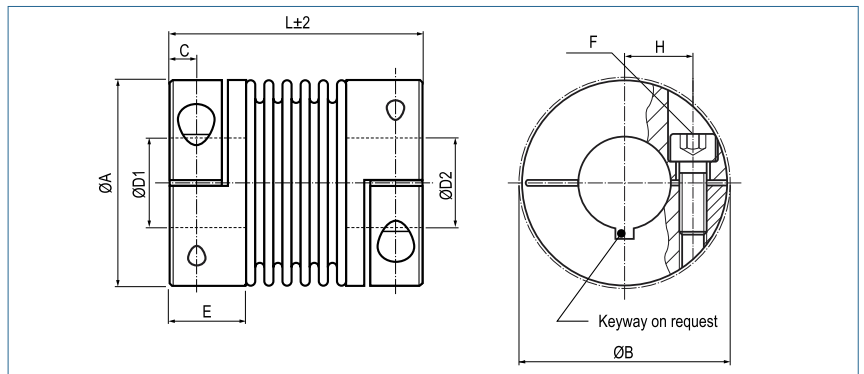

Order Code

KB4AL / 80 - 91 - 15 - 20 - (S)

Type / Size

Length
L

ØD1
(H7)

ØD2
(H7)

Options

Size	Torque TKN (Nm)	Dimensions (mm)								Technical Data								
		L	Ø A	D1/D2	H	C	E	F	Mass (kg)	Moment of Inertia J (g m ²)	Spring Stiffness			Misalignment			max speed min ⁻¹	
		Length	Outer Ø	Bore Sizes (H7) min~max				Screw (ISO4762) TA (Nm)			torsional CT 10 ³ (Nm/rad)	radial CR (N/mm)	axial CA (N/mm)	radial ΔKr (mm)	axial ΔKa (mm)	angular ΔKw (°)		
80	80	91	82	12-44	28	11	33.5	82.9	M10	0.8	0.90	128	1200	80	0.2	0.5	1.5	6900
		84							0.85	0.95	75	400	50	0.25	0.8	2	6900	
150	150	91	82	14-44	28	11	33.5	82.9	M10	0.9	1.0	155	2020	145	0.2	0.5	1.5	6900
		84							0.95	1.05	105	595	85	0.25	0.8	2	6900	
200	200	101	90	16-47	31	13	38	90.8	M12	1.17	1.49	175	2500	145	0.2	0.5	1.5	6400
		125							1.21	1.57	120	460	82	0.25	0.8	2	6400	
300	300	105	110	20-60	40	13	38	110	M12	1.62	3.28	502	6300	280	0.2	0.5	1.5	6000
		145							1.66	3.37	285	1400	145	0.25	0.8	2	6000	
500	500	112	122	25-70	42	15	42	122	M12	2.4	6.4	690	7790	100	0.2	0.5	1.5	5000
		145							2.5	6.7	320	970	85	0.25	1.0	2	5000	

Material	bellows - stainless steel hub - aluminium
Hub	bore tolerance: H7
Temperature Range	-30 °C ~ 120 °C
Keyway	optional acc. DIN 6885

Metal Bellows Coupling compact

with Collet Clamps

optional
laserwelded
optional full stainless
steel version

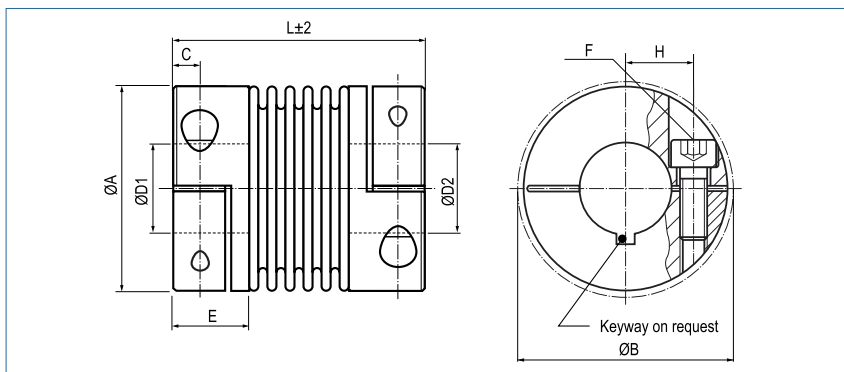

Order Code

KB4C / 60 - 67 - 12 - 32 - (S)

Type / Size

Length
L

ØD1
(H7)

ØD2
(H7)

Options

Size	Torque TKN (Nm)	Dimensions (mm)								Technical Data								
		L	Ø A	D1/D2	H	C	E	B	F	Mass (kg)	Moment of Inertia J (g m²)	Spring Stiffness			Misalignment			max. speed min-1
		Length	Outer Ø	Bore Sizes (H7) min~max					Screw (ISO4762) TA (Nm)			torsional CT 10³ (Nm/rad)	radial CR (N/mm)	axial CA (N/mm)	radial ΔKr (mm)	axial ΔKa (mm)	angular ΔKw (°)	
18	18	58	45	10-25.4	17	5.5	17.5	47.4	M5	0.07	0.03	20	205	50	0.2	0.5	1.5	12800
		8							0.12	0.04	15	82	36	0.25	0.5	2	12800	
30	30	58	56	10-32	20	7.3	21	56.4	M6	0.26	0.13	38	720	50	0.15	0.6	1.5	10300
		15		0.27					0.14	28	225	28	0.25	1	2	10300		
60	60	67	66	12-35	24	8.6	24	66.2	M8	0.38	0.28	75	1150	90	0.15	0.6	1.5	8700
		40		0.42					0.31	50	340	50	0.25	1	2	8700		
80	80	78	82	12-44	28	9.8	27	82.9	M10	0.70	0.78	128	1200	80	0.2	0.5	1.5	6900
		84		0.76					0.85	75	400	50	0.25	0.8	2	6900		
150	150	78	82	14-44	28	9.8	27	82.9	M10	0.73	0.82	155	2020	145	0.2	0.5	1.5	6900
		84		0.80					0.89	105	595	85	0.25	0.8	2	6900		
200	200	83	90	16-47	31	10.8	29	90.8	M12	0.89	1.19	175	2500	145	0.2	0.5	1.5	6400
		125		0.95					1.27	120	460	82	0.25	0.8	2	6400		
300	300	94	110	20-60	39	11.8	32.5	110	M12	1.37	2.74	502	6300	280	0.2	0.5	1.5	6000
		145		1.43					2.86	285	1400	145	0.25	0.8	2	6000		
500	500	100	122	25-70	45	13.3	36	122	M12	1.81	4.45	690	7790	100	0.2	0.5	1.5	5000
		145		1.91					4.69	320	970	85	0.25	1	2	5000		

Material	bellows - stainless steel hub - aluminium
Hub	bore tolerance: H7
Temperature Range	-30 °C ~ 120 °C
Keyway	optional acc. DIN 6885 biggest bore marked with a #

Metal Bellows Coupling

with adapting flange

optional
laserwelded
optional full stainless
steel version

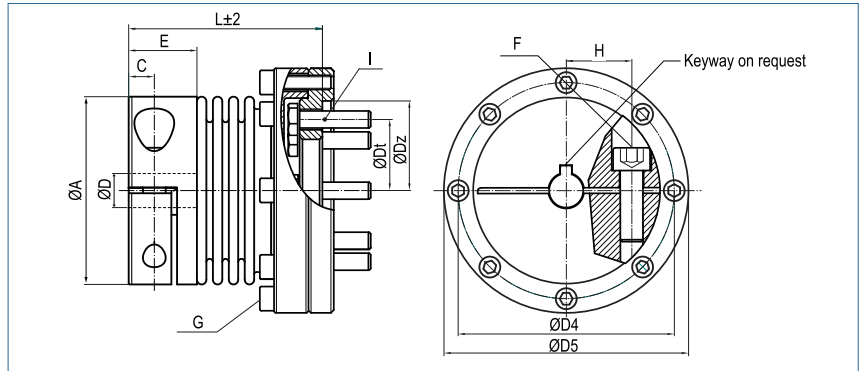

Order Code

KB4F / 150 - 79 - 30 - 63

Type / Size

Length
L

ØD
(H7)

Dt

Size	Torque TKN (Nm)	Dimensions (mm)								Technical Data								
		L	Ø A	D1	H	C	E	D4	F	Mass (kg)	Moment of Inertia J (g m²)	Spring Stiffness			Misalignment			max. speed (min-1)
		Length	Outer Ø	Bore Size (H7) min~max					Screw (ISO4762) TA (Nm)			torsional CT 10³ (Nm/rad)	radial CR (N/mm)	axial CA (N/mm)	radial ΔKr (mm)	axial ΔKa (mm)	angular ΔKw (°)	
18	18	63	45	10-25.4	17	5.5	17.5	56.5	M5	0.50	0.15	20	205	50	0.2	0.5	1.5	12800
		71							8	0.52	0.16	15	82	36	0.25	0.5	2	
30	30	61	56	10-32	20	7.3	21	65	M6	0.70	0.20	38	720	50	0.15	0.6	1.5	10300
		69		15					0.72	0.21	28	225	28	0.25	1.0	2		
60	60	68	66	12-35	23	8.6	24	76	M8	1.00	0.65	75	1150	90	0.15	0.6	1.5	8700
		78		40					1.05	0.68	50	340	50	0.25	1.0	2		
150	150	79	82	14-44	28	9.8	27	94	M10	1.65	1.30	155	2020	145	0.2	0.5	1.5	6900
		90		84					1.75	1.37	105	595	85	0.25	0.8	2		
300	300	90	110	30-60	39	11.8	32.5	120	M12	2.90	5.50	502	6300	280	0.2	0.5	1.5	6000
		101		145					3.00	5.62	285	1400	145	0.25	0.8	2		
500	500	100	122	35-70	45	13.3	36	142	M12	4.55	9.00	690	7790	100	0.2	0.5	1.5	5000
		111		145					4.70	9.15	320	970	85	0.25	1	2		
1400	1400	140	157	50-80	55	22.5	55	171	2xM20	10.50	45	1270	700	275	0.2	0.8	1.8	5000
									470									



Material	bellows - stainless steel collet clamps - to Size 500: high-tensile aluminium collet clamps - Size 1400: Steel flanges - steel
Hub	bore tolerance: H7
Temperature Range	-30 °C ~ 120 °C -30 °C ~ 250 °C (Size 1400)
Keyway	optional acc. DIN 6885 biggest bore marked with a #

Size	Dimensions (mm)				
	G	D5	Dt	Dz	I
	Screw (ISO4762) / TA (Nm)		PCD	H7	Screw (ISO4017) / TA (Nm)
18	8 x M4 / 4.5Nm	63.5	31.5	40	8 x M5 / 7.6Nm
30	8 x M5 / 8Nm	74	40	50	8 x M6 / 13.2Nm
60	8 x M5 / 8Nm	86	50	63	8 x M6 / 13.2Nm
150	8 x M6 / 15Nm	104	63	80	12 x M6 / 13.2Nm
300	12 x M6 / 15Nm	132	80	100	12 x M8 / 31.8Nm
500	12 x M8 / 40Nm	155	100	130	12 x M10 / 63Nm
1400	16 x M8 / 40Nm	184	125	160	12 x M10 / 63Nm

Metal Bellows Coupling

with split hubs

optional
laserwelded
optional full stainless
steel version

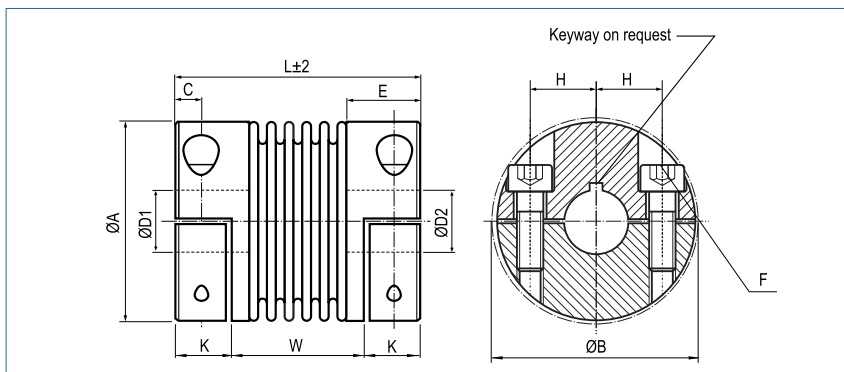

Order Code

KB4H / 60 - 83 - 20 - 20 - (S)

Type / Size

Length
L

ØD1
(H7)

ØD2
(H7)

Options

Size	Torque TKN (Nm)	Dimensions (mm)										Technical Data								
		L Length (±2)	Ø A Outer Ø	D1/D2 Bore Sizes (H7) min-max	H	C	E	W	K	B	F Screw (ISO4762) TA (Nm)	Mass (kg)	Moment of Inertia J	Spring Stiffness			Misalignment			max. speed (min-1)
													torsional CT 10 ³ (Nm/rad)	radial CR (N/mm)	axial CA (N/mm)	radial ΔKr (mm)	axial ΔKa (mm)	angular ΔKw (°)		
18	18	63	45	10-25.4	17	5.5	19.5	37	13	47.4	M5	0.1	0.04	20	205	50	0.2	0.5	1.5	12800
		71						45												
30	30	69	56	10-32	20	7.5	27	35	17	56.4	M6	0.3	0.14	38	720	50	0.15	0.6	1.5	10300
		77		43				15												
60	60	83	66	12-35	23	9.5	31	41	21	66.2	M8	0.5	0.28	75	1150	90	0.15	0.6	1.5	8700
		93						51												
80	80	94	82	12-44	28	11	36	47	23.5	82.9	M10	0.9	0.65	128	1200	80	0.2	0.5	1.5	6900
		106						59												
150	150	95	82	14-44	28	11	36	48	23.5	82.9	M10	0.9	0.82	155	2020	145	0.2	0.5	1.5	6900
		107						60												
200	200	105	90	16-47	31	12.5	41	51	27	90.8	M12	1.3	2.2	175	2500	145	0.2	0.5	1.5	6400
		117						63												
300	300	111	110	20-60	39	13	41	55	28	110	M12	1.8	4.2	502	6300	280	0.2	0.5	1.5	6000
		125						69												
500	500	133	122	25-70	42	15	51	62	35.5	122	M12	2.50	8.6	690	7790	100	0.2	0.5	1.5	5000
		146						75												
800	800	168	157	40-80	55	22.5	66.5	77	45.5	168	M20 400	14.8	57.65	1270	700	275	0.2	0.8	1.8	5000
1400	1400	168	157	50-80	55	22.5	66.5	77	45.5	168	M20 400	15.3	58.70	1270	700	275	0.2	0.8	1.8	5000



Material

bellows - stainless steel
hub - to size 500: aluminium
hub - from size 800: steel

Hub

bore tolerance: H7

Temperature Range

-30 °C ~ 120 °C
size 800/1400: -30 °C ~ 250 °C

Keyway

optional acc. DIN 6885
biggest bore marked with a #

Metal Bellows Coupling

with split hubs, compact

optional
laserwelded
optional full stainless
steel version

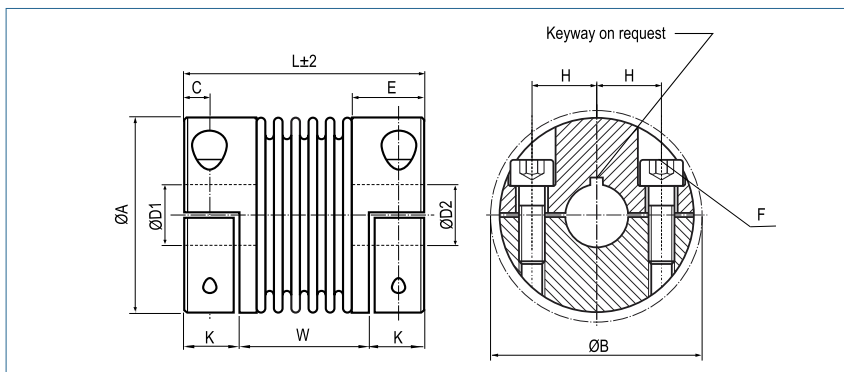

Order Code

KB4HC / 60 - 67 - 20 - 20 - (S)

Type / Size

Length
L

ØD1
(H7)

ØD2
(H7)

Options

Size	Torque TKN (Nm)	Dimensions (mm)										Technical Data								
		L Length	Ø A Outer Ø	D1/D2 Bore Sizes (H7) min~max	H	C	E	W	K	B	F Screw (ISO4762) TA (Nm)	Mass (kg)	Moment of Inertia J	Spring Stiffness			Misalignment			max. speed (min-1)
													torsional CT 10³ (Nm/rad)	radial CR (N/mm)	axial CA (N/mm)	radial ΔKr (mm)	axial ΔKa (mm)	angular ΔKw (°)		
18	18	58	45	10-25.4	17	5.5	17.5	36	11	47.4	M5	0.07	0.03	20	205	50	0.2	0.5	1.5	12800
		66						44												
30	30	58	56	10-32	20	7.3	21	31	13.5	56.4	M6	0.26	0.13	38	720	50	0.15	0.6	1.5	10300
		66		39				15												
60	60	67	66	12-35	23	8.6	24	33	17	66.2	M8	0.38	0.28	75	1150	90	0.15	0.6	1.5	8700
		77						43												
80	80	78	82	12-44	28	9.8	27	42	18	82.9	M10	0.70	0.78	128	1200	80	0.2	0.5	1.5	6900
		89						53												
150	150	78	82	14-44	28	9.8	27	42	18	82.9	M10	0.73	0.82	155	2020	145	0.2	0.5	1.5	6900
		89						53												
200	200	83	90	16-47	31	10.8	29	43	20	90.8	M12	0.89	1.19	175	2500	145	0.2	0.5	1.5	6400
		94						54												
300	300	94	110	20-60	39	11.8	32.5	50	22	110	M12	1.37	2.74	502	6300	280	0.2	0.5	1.5	6000
		105						61												
500	500	100	122	25-70	45	13.3	36	48	26	122	M12	1.81	4.45	690	7790	100	0.2	0.5	1.5	5000
		111						59												



Material	bellows - stainless steel hub - aluminium
Hub	bore tolerance: H7
Temperature Range	-30 °C ~ 120 °C
Keyway	optional acc. DIN 6885 biggest bore marked with a #

Metal Bellows Coupling

with collet clamps

optional
laserwelded
optional full stainless
steel version

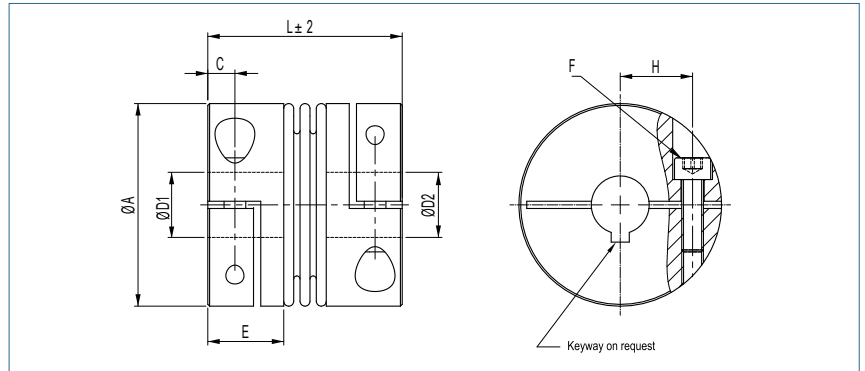

Order Code

KB4K / 400 - 75 - 44 - 40 - (S)

Type / Size

Length
L

ØD1
(H7)

ØD2
(H7)

Options

Size	Torque TKN (Nm)	Dimensions (mm)							Technical Data								
		L	Ø A	D1/D2	H	C	E	F	Mass (kg)	Moment of Inertia J (g m ²)	Spring Stiffness			Misalignment			max speed (min-1)
		Length	Outer Ø	Bore Sizes (H7) min-max				Screw (ISO4762) TA (Nm)			torsional CT 10 ³ (Nm/rad)	radial CR (N/mm)	axial CA (N/mm)	radial ΔKr (mm)	axial ΔKa (mm)	angular ΔKw (°)	
40	40	46	45	10-25.4	17	5.5	17.5	M5 8	0.07	0.04	3	3350	97	0.05	0.5	0.5	12800
80	80	55	56	12-32 30#	20	7.3	21	M6 15	0.26	0.14	11	6436	165	0.05	0.5	0.5	10300
200	200	60	66	16-35	23	8.6	23	M8 40	0.38	0.28	40	12442	287	0.1	1	0.5	8700
400	400	75	82	32-44	28	9.8	27	M10 84	0.70	0.82	76	6815	338	0.1	1	0.5	6900
650	650	78	90	37-47	39	10.8	29	M12 125	0.89	1.19	103	7910	386	0.1	1.5	1	6400
1000	1000	89	110	42-60	39	11.8	32,5	M12 145	1.37	2.74	1252	29096	756	0.1	1.5	1	6000
1500	1500	96	122	50-70	45	13.3	36	M12 145	1.81	4.45	693	20694	639	0.1	1.5	1	5000

Material	bellows - stainless steel hub - aluminium
Hub	bore tolerance: H7
Temperature Range	-30 °C ~ 120 °C
Keyway	optional acc. DIN 6885 biggest bore marked with a #

Metal Bellows Coupling

axial pluggable, with collet clamps

optional
laserwelded
optional full stainless
steel version

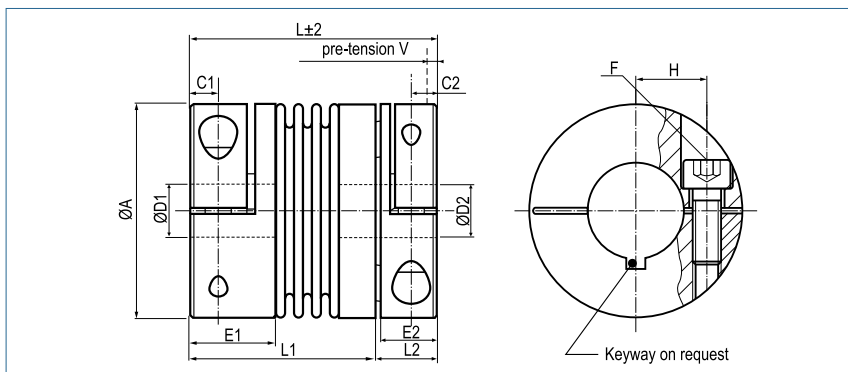
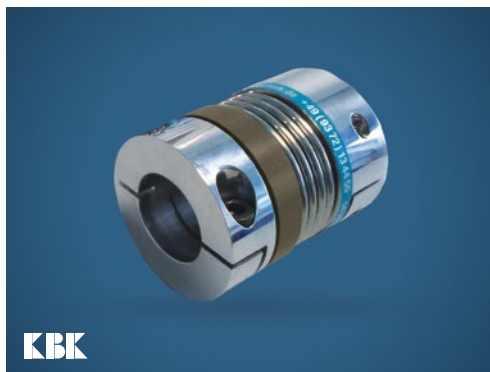

Order Code

KB4P / 150 - 95 - 44 - 28 - D - (S)

Type / Size

Length
L

ØD1
(H7)

ØD2
(H7)

Plug System

Options

Size	Torque TKN (Nm)	Dimensions (mm)										Technical Data								
		L Length	Ø A Outer Ø	D1/D2 Bore Sizes (H7) min-max	H	C1	C2	E1	E2	B	F	Screw (ISO4762) TA (Nm)	Mass (kg)	Moment of Inertia J (g m ²)	Spring Stiffness			Misalignment		
													torsional CT 10° (Nm/rad)	radial CR (N/mm)	axial CA (N/mm)	radial ΔKr (mm)	axial ΔKa (mm)	angular ΔKw (°)		
18	18	62	45	10-24	17	5.5	5.5	17.5	12	47.4	M5	0.14	0.05	20	205	50	0.2	0.5	1.5	12800
		70									8	0.19	0.06	15	82	36	0.25	0.5	2	
30	30	73	56	10-30	20	7.5	7.3	24.5	17	56.4	M6	0.29	0.14	38	720	50	0.15	0.6	1.5	10300
		81									15	0.31	0.15	28	225	28	0.25	1.0	2	
60	60	85	66	12-35	23	10	8.6	29	21	66	M8	0.47	0.33	75	1150	90	0.15	0.6	1.5	8700
		95									40	0.57	0.36	50	340	50	0.25	1.0	2	
80	80	95	82	12-44	28	11	9.8	33.5	21.5	82.9	M10	0.81	0.89	128	1200	80	0.2	0.5	1.5	6900
		106									84	0.90	0.99	75	400	50	0.25	0.8	2	
150	150	95	82	14-44	28	11	9.8	33.5	21.5	82.9	M10	0.91	1.08	155	2020	145	0.2	0.5	1.5	6900
		106									84	1.00	1.18	105	595	85	0.25	0.8	2	
200	200	105	90	16-47	39	13	10.8	38	24	90.8	M12	1.16	1.47	175	2500	145	0.2	0.5	1.5	6400
		117									125	1.26	1.67	120	460	82	0.25	0.8	2	
300	300	114	110	20-60	39	13	10.8	38	27	110	M12	1.68	3.33	502	6300	280	0.2	0.5	1.5	6000
		125									145	1.78	3.53	285	1400	145	0.25	0.8	2	
500	500	136	122	25-70	45	15	13.3	42	42	122	M12	2.50	6.21	690	7790	100	0.2	0.5	1.5	5000
		147									145	2.60	6.41	320	970	85	0.25	1.0	2	



Material	bellows – stainless steel hub - high-tensile aluminium
Hub	bore tolerance: H7
Keyway	optional acc. DIN 6885
Temperature Range	-30 °C ~ 120 °C

Size	Dimensions (mm)			
	L1	L2	L3	V
18	48	14	22	0.5-1.0
	56			
30	54	19	31	0.5-1.0
	62			
60	62	23	35	0.5-1.5
	72			
80	71.5	23.5	37.5	0.5-1.5
	82.5			
150	71.5	23.5	37.5	0.5-1.5
	82.5			
200	79	26	42	0.5-1.5
	91			
300	85	29	47	0.5-1.5
	96			
500	92	44	66	0.5-2.0
	103			

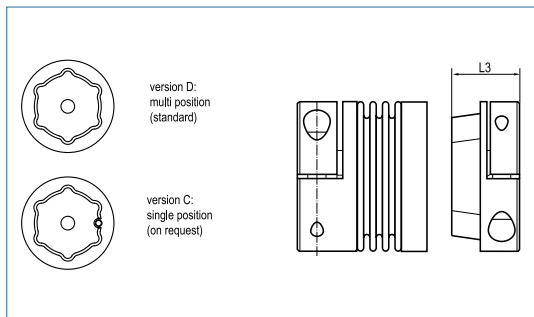

Metal Bellows Coupling

with stainless steel collet clamps

optional
laserwelded

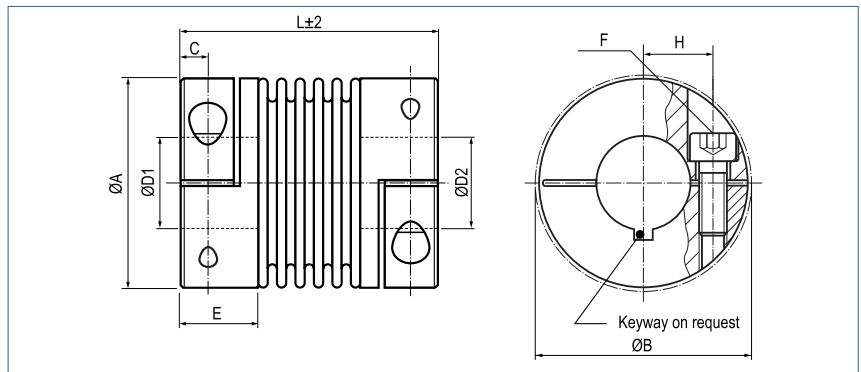

Order Code

KB4 / 60 - 89 - 12 - 32 - VA/VAW

Type / Size

Length
L

ØD1
(H7)

ØD2
(H7)

Stainless Steel
glued / laserwelded

Size	Torque TKN (Nm)	Dimensions (mm)								Technical Data								
		L	Ø A	D1/D2	H	C	E	B	F	Mass (kg)	Moment of Inertia J (g m²)	Spring Stiffness			Misalignment			max speed min-1
		Length	Outer Ø	Bore Sizes (H7) min-max					Screw (ISO4762) TA (Nm)			torsional CT 10³ (Nm/rad)	radial CR (N/mm)	axial CA (N/mm)	radial ΔKr (mm)	axial ΔKa (mm)	angular ΔKw (°)	
18	18	63	45	10-25.4	17	5.5	19.5	47.4	M5	0.27	0.11	20	205	50	0.2	0.5	1.5	12800
		71							8	0.41	0.14	15	82	36	0.25	0.5	2	12800
30	30	65	56	10-32 #30	20	7.5	24.5	56.4	M6	0.83	0.41	38	720	50	0.15	0.6	1.5	10300
		73							15	0.89	0.44	28	225	28	0.25	1	2	10300
60	60	79	66	12-35	23	10	29	66	M8	1.4	0.91	75	1150	90	0.15	0.6	1.5	8700
		89							40	1.7	1.00	50	340	50	0.25	1	2	8700
80	80	91	82	14-44	28	11	33.5	82.9	M10	2.3	2	128	1200	80	0.2	0.5	1.5	6900
		102							84	2.4	2.1	75	400	50	0.25	0.8	2	6900
150	150	91	82	19-44	28	11	33.5	82.9	M10	2.3	2	155	2020	145	0.2	0.5	1.5	6900
		102							84	2.4	2.1	105	595	85	0.25	0.8	2	6900
200	200	101	90	22-47	31	13	38	90.8	M12	2.6	3.3	175	2500	145	0.2	0.5	1.5	6400
		113							125	2.7	3.5	120	460	82	0.25	0.8	2	6400
300	300	105	110	30-60	40	13	38	110	M12	3.6	7.3	502	6300	280	0.2	0.5	1.5	6000
		116							145	3.7	7.5	285	1400	145	0.25	0.8	2	6000
500	500	112	122	35-70	42	15	42	122	M12	5.1	12.4	690	7790	100	0.2	0.5	1.5	5000
		123							145	5.2	12.7	320	970	85	0.25	1	2	5000

Material	bellows - stainless steel hub - stainless steel
Hub	bore tolerance: H7
Temperature Range	VA -30 °C ~ 120 °C (glued) VAW -30 °C ~ 250 °C (laserwelded)
Keyway	optional acc. DIN 6885 biggest bore marked with a #

Metal Bellows Coupling

with inner conical hubs

optional
laserwelded
optional full stainless
steel version

optional chem.
nickel-plated

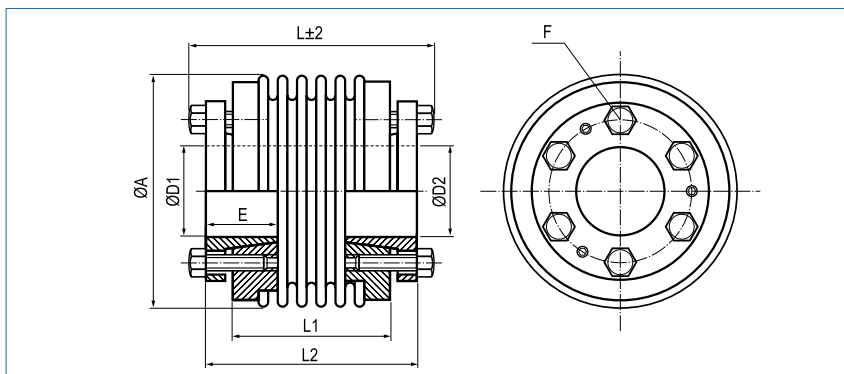

Order Code

KB5 / 60 - 73 - 20 - 25 - (S)

Type / Size

Length
L

ØD1
(H7)

ØD2
(H7)

Options

Size	Torque TKN (Nm)	Dimensions (mm)							Technical Data								
		L	Ø A	D1/D2	E	L1	L2	F	Mass (kg)	Moment of Inertia J (g m ²)	Spring Stiffness			Misalignment			max. speed (min-1)
		Length (±2)	Outer Ø	Bore Sizes (H7) min~max	Hub- length			Screw (ISO4017) TA (Nm)			torsional CT 10 ³ (Nm/rad)	radial CR (N/mm)	axial CA (N/mm)	radial ΔKr (mm)	axial ΔKa (mm)	angular ΔKw (°)	
18	18	63	45	10-18	20	38	56	4xM5	0.36	0.075	20	205	50	0.2	0.5	1.5	11500
		71				46	64	4.5	0.37	0.078	15	82	36	0.25	0.5	2	
30	30	53	56	12-20	20	30	46	6xM5	0.4	0.11	38	720	50	0.15	0.6	1.5	11000
		61				38	54	4.5	0.42	0.12	28	225	25	0.25	1	2	
60	60	62	66	15-25	25	36	54	6xM6	0.77	0.32	75	1150	90	0.15	0.6	1.5	9100
		73				47	65	8.5	0.79	0.34	50	340	50	0.25	1	2	
80	80	78	82	20-35	30	50	70	6xM6	1.34	1.05	128	1200	80	0.2	0.5	1.5	7000
		90				62	82	10	1.39	1.11	75	400	50	0.25	0.8	2	
150	150	78	82	20-35	30	50	70	6xM6	1.36	1.15	155	2020	145	0.2	0.5	1.5	7000
		90				62	82	15	1.41	1.21	105	595	85	0.25	0.8	2	
200	200	78	90	20-40	30	50	70	6xM6	1.59	1.39	175	2500	145	0.2	0.5	1.5	6700
		91				63	83	15	1.66	1.49	120	460	82	0.25	1	2	
300	300	90	110	25-50	37	56	80	6xM8	3.26	4.66	502	6300	280	0.2	0.5	1.5	5200
		102				67	91	17	3.32	4.81	285	1400	145	0.25	1	2	
500	500	101	122	35-55	40	66	90	6xM8	3.78	6.11	690	7790	100	0.2	0.5	1.5	4600
		112				77	101	25	3.87	6.38	320	970	85	0.25	1	2	
800	800	170	157	50-70	60	110	150	6xM16 45	9.05	24.05	760	500	185	0.2	0.8	1.8	3700
1400	1400	170	157	50-70	60	110	150	6xM16 80	9.15	24.2	1270	700	275	0.2	0.8	1.8	3700
3000	3000	206	157	55-85	60	150	190	6xM12 85	9.43	25.7	2810	29450	1300	0.2	0.8	1.5	2800
5000	5000	206	208	60-90	80	146	186	6xM16 210	19.9	96.7	4810	4915	505	0.2	0.8	1.5	2800

Material	bellows – stainless steel hub - steel
Hub	bore tolerance: H7
Temperature Range	-30 °C ~ 120 °C

Metal Bellows Coupling

with outer conical hubs

optional
laserwelded
optional full stainless
steel version

optional chem.
nickel-plated

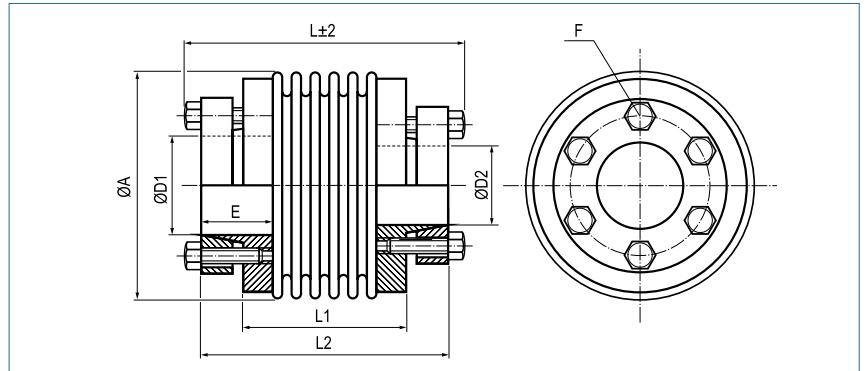

Order Code

KB6 / 60 - 78 - 20 - 32 - (S)

Type / Size Length L ØD1 (H7) ØD2 (H7) Options

Size	Torque TKN (Nm)	Dimensions (mm)							Technical Data								
		L	Ø A	D1/D2	E	L1	L2	F	Mass (kg)	Moment of Inertia J (g m ²)	Spring Stiffness			Misalignment			max. speed (min-1)
		Length	Outer Ø	Bore Sizes (H7) min-max	Hub-length			Screw (ISO4017) TA (Nm)			torsional CT 10 ³ (Nm/rad)	radial CR (N/mm)	axial CA (N/mm)	radial ΔKr (mm)	axial ΔKa (mm)	angular ΔKw (°)	
18	18	65	45	8-15	16.5	37	58	4x M5	0.3	0.081	20	205	50	0.2	0.5	1.5	11500
		73				45	66	5.9	0.31	0.084	15	82	36	0.25	0.5	2	
30	30	60	56	12-20	18	31	53	6x M5	0.37	0.13	38	720	50	0.15	0.6	1.5	11000
		68				61	5.9	0.39	0.14	28	225	25	0.25	1	2		
60	60	78	66	15-32	25	36	71	6x M5	0.76	0.46	75	1150	90	0.15	0.6	1.5	9100
		89				82	8.7	0.79	0.49	50	340	50	0.25	1	2		
80	80	95	82	20-35	31	50	87	6x M6	1.57	1.37	128	1200	80	0.2	0.5	1.5	7000
		107				99	15	1.62	1.43	75	400	50	0.25	0.8	2		
150	150	95	82	20-35	31	50	87	6x M6	1.59	1.39	155	2020	145	0.2	0.5	1.5	7000
		107				99	15	1.64	1.45	105	595	85	0.25	0.8	2		
200	200	95	90	20-42	31	50	87	6x M6	1.6	1.64	175	2500	145	0.2	0.5	1.5	6700
		108				100	15	1.67	1.74	120	460	82	0.25	1	2		
300	300	108	110	25-50	34	57	98	6x M8	2.83	4.52	502	6300	280	0.2	0.5	1.5	5200
		120				109	25	2.89	4.68	285	1400	145	0.25	1	2		
500	500	122	122	35-55	41	59	112	6x M8	3.89	7.04	690	7790	100	0.2	0.5	1.5	4600
		134				123	36	3.98	7.31	320	970	85	0.25	1	2		
800	800	184	157	50-70	50	108	169	6x M12 85	8.87	24.9	760	500	185	0.2	0.8	1.8	3700
1400	1400	184	157	50-70	50	108	169	6x M12 115	8.92	25.2	1270	700	275	0.2	0.8	1.8	3700
3000	3000	220	157	55-75	60	146	204	6x M12 125	10.9	30.9	2810	2945	305	0.2	0.8	1.5	2800
5000	5000	245	208	60-90	55	146	225	6x M16 210	27.7	144.4	4810	4915	505	0.2	0.8	1.5	2800

Material	bellows – stainless steel hub - steel
Hub	bore tolerance: H7
Temperature Range	-30 °C ~ 120 °C

Metal Bellows Coupling

axial pluggable, with outer conical hubs

optional
laserwelded
optional full stainless
steel version

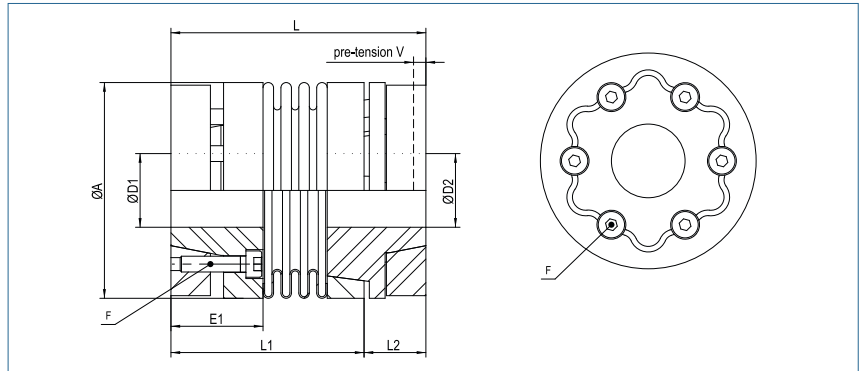

Order Code

KB6P / 60 - 79 - 20 - 15 - D - (S)

Type / Size

Length
L

ØD1
(H7)

ØD2
(H7)

Plug System

Options

Size	Torque TKN (Nm)	Dimensions (mm)						Technical Data								
		L	Ø A	D1	D2	E1	F	Mass (kg)	Moment of Inertia J (g m²)	Spring Stiffness			Misalignment			max. speed (min-1)
		Length	Outer Ø	Bore Size (H7) min~max	Bore Size (H7) min~max		Screw (ISO4762) TA (Nm)			torsional CT 10³ (Nm/rad)	radial CR (N/mm)	axial CA (N/mm)	radial ΔKr (mm)	axial ΔKa (mm)	angular ΔKw (°)	
18	18	67	45	8-14	10-22	20.5	M4	0.4	0.1	20	205	50	0.2	0.5	1.5	12800
		75					4.3	0.45	0.11	15	82	36	0.25	0.5	2	
30	30	68	56	10-24	10-24	22	M5	0.48	0.16	38	720	50	0.15	0.6	1.5	10300
		76					6.5	0.5	0.18	28	225	28	0.25	1.0	2	
60	60	79	66	12-32	12-32	24	M5	0.88	0.38	75	1150	90	0.15	0.6	1.5	8700
		89					8	0.98	0.41	50	340	50	0.25	1.0	2	
150	150	97	82	15-40	15-40	35	M6	1.6	1.8	155	2020	145	0.2	0.5	1.5	6900
		108					12	1.69	1.85	105	595	85	0.25	0.8	2	
300	300	113	110	24-56	24-56	35	M8	2.28	4.05	502	6300	280	0.2	0.5	1.5	6000
		125					30	2.38	4.25	285	1400	145	0.25	0.8	2	
500	500	133	122	30-60	30-60	40	M8	3.8	7.55	690	7790	100	0.2	0.5	1.5	5000
		144					32	3.9	7.75	320	970	85	0.25	1.0	2	



Material	bellows - stainless steel hubs - aluminium outer conical hub - steel
Hub	bore tolerance: H7
Temperature Range	-30 °C ~ 120 °C

Size	Dimensions (mm)			
	L1	L2	L3	V
18	52	15	22	0.5-1.0
	60			
30	51.5	16.5	31	0.5-1.0
	59.5			
60	57	22	35	0.5-1.5
	67			
150	73	24	37.5	0.5-1.5
	84			
300	82	31	48	0.5-1.5
	93			
500	90	43	64	0.5-2.0
	101			

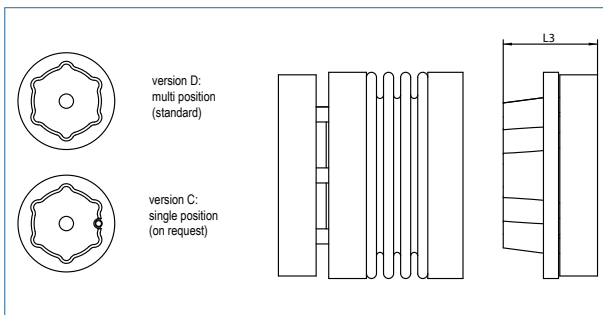

Metal Bellows Coupling

for flange mounting

optional
laserwelded
optional full stainless
steel version

optional chem.
nickel-plated

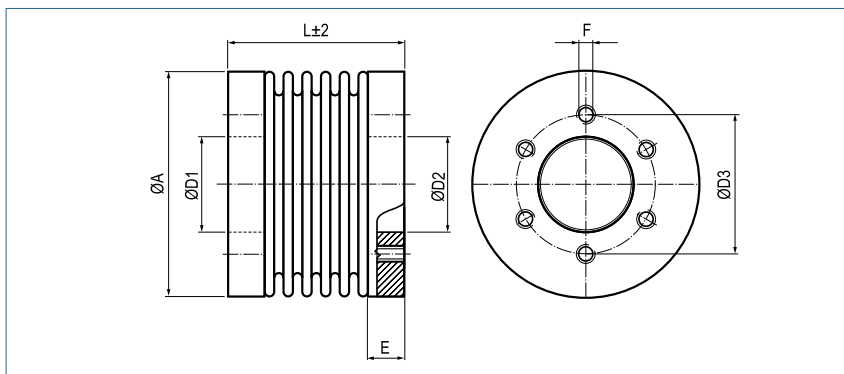
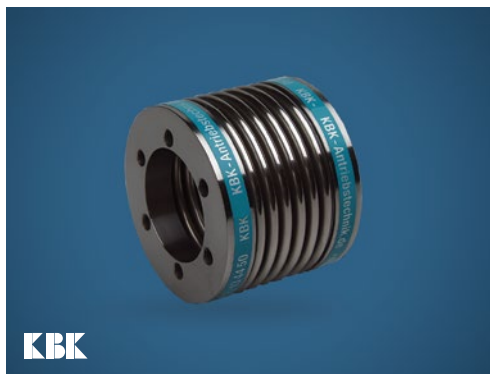

Order Code

KB7 / 60 - 41 - 38 - (S)

Type / Size

Length
L

ØD1/ØD2
(H7)

Options

Size	Torque TKN (Nm)	Dimensions (mm)						Technical Data								
		L	Ø A	Ø D1/D2	Ø D3	E	F	Mass (kg)	Moment of Inertia J (g m ²)	Spring Stiffness			Misalignment			max. speed (min ⁻¹)
		Length	Outer Ø	Bore Sizes (H7) min-max			Thread 6x			torsional CT 10 ³ (Nm/rad)	radial CR (N/mm)	axial CA (N/mm)	radial ΔKr (mm)	axial ΔKa (mm)	angular ΔKw (°)	
18	18	36	45	22	31	6	M5	0.11	0.04	20	205	50	0.2	0.5	1.5	11500
		44						0.115	0.04	15	82	36	0.25	0.5	2	
30	30	30	56	28	37	7	M5	0.16	0.09	38	720	50	0.15	0.6	1.5	11000
		38						0.17	0.09	28	225	25	0.25	1	2	
60	60	41	66	38	46	10.5	M6	0.33	0.25	75	1150	90	0.15	0.6	1.5	9100
		51						0.37	0.29	50	340	50	0.25	1	2	
80	80	50	82	50	62	13	M6	0.69	0.83	128	1200	80	0.2	0.5	1.5	7000
		62						0.75	0.92	75	400	50	0.25	1	2	
150	150	50	82	50	62	13	M6	0.69	0.83	155	2020	145	0.2	0.5	1.5	7000
		62						0.75	0.92	105	595	85	0.25	1	2	
200	200	50	90	50	62	13	M6	0.74	1.0	175	2500	145	0.2	0.5	1.5	6700
		63						0.80	1.1	120	460	82	0.25	1	2	
300	300	55	110	65	80	13	M8	1.18	2.5	502	6300	280	0.2	0.5	1.5	5200
		66						1.24	2.7	285	1400	145	0.25	1	2	
500	500	61	122	70	94	16	M8	1.95	5.0	690	7790	100	0.2	0.5	1.5	4600
		72						2.05	5.3	320	970	85	0.25	1	2	
800	800	131	157	85	110	23	M16	3.55	15	760	500	185	0.2	0.8	1.8	3700
1400	1400	131	157	85	110	23	M16	3.55	15	1270	700	275	0.2	0.8	1.8	3700
3000	3000	131	157	85	110	23	M16	3.70	16	2810	2945	305	0.2	0.8	1.5	2800
5000	5000	146	208	100	130	36.5	M16	8.22	61	4810	4915	505	0.2	0.8	1.5	2800

Material	bellows – stainless steel hub - steel
Hub	bore tolerance: H7
Temperature Range	-30 °C ~ 120 °C

Metal Bellows Coupling

with expanding clamps

optional
laserwelded
optional full stainless
steel version

optional chem.
nickel-plated

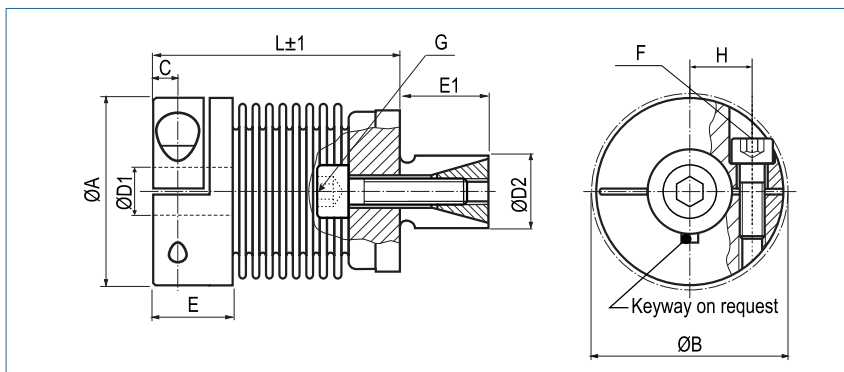

Order Code

KB8 / 30	-	53	-	15	-	20	-	S
Type / Size		Length L		ØD1 (H7)		ØD2 (f7)		Options

Size	Torque TKN (Nm)	Dimensions (mm)										Technical Data								
		L	Ø A	D1	D2	H	C	E	E1	B	F/G	Mass (kg)	Moment of Inertia J (g m²)	Spring Stiffness			Misalignment			max. speed (min-1)
		Length	Outer Ø	Bore Size (H7) min-max	(f7) min-max						Screw (ISO4762) TA (Nm)			torsional CT 10³ (Nmrad)	radial CR (N/mm)	axial CA (N/mm)	radial ΔKr (mm)	axial ΔKa (mm)	angular ΔKw (°)	
18	18	45	45	10-25.4	13-25	17	5.5	17.5	20	47.4	M5	0.14	0.04	20	205	50	0.2	0.5	1.5	12800
		8									0.15	0.05	15	82	35	0.25	0.5	2	12800	
30	30	53	56	10-32 #30	14-30	20	7.5	24.5	25	56.4	M6	0.30	0.15	38	720	50	0.15	0.6	1.5	10300
		15									0.31	0.16	28	225	28	0.25	1.0	2	10300	
60	60	62	66	12-35	23-38	23	10	29	27	66	M8	0.40	0.28	75	1150	90	0.15	0.6	1.5	8700
		40									0.42	0.31	50	340	50	0.25	1.0	2	8700	
150	150	71	82	14-44	26-42	28	11	33.5	32	82.9	M10	0.80	0.90	155	2020	145	0.2	0.5	1.5	6900
		84									0.85	0.95	105	595	85	0.25	0.5	2	6900	
300	300	84	110	20-60	38-60	39	13	38	45	110	M12	1.62	3.28	502	6300	280	0.2	0.5	1.5	6000
		145									1.66	3.37	285	1400	145	0.25	0.8	2	6000	

Material	bellows – stainless steel collet clamps - aluminium expanding clamps - steel
Hub and Hollow Shaft	bore tolerance: H7
Keyway	optional acc. DIN 6885 biggest bore marked with a #
Temperature Range	-30 °C ~ 120 °C

Metal Bellows Coupling

axial pluggable, with expanding clamps

optional
laserwelded
optional full stainless
steel version

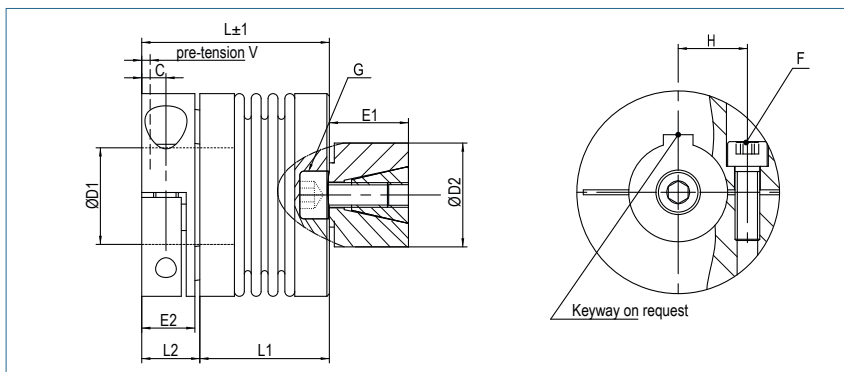

Order Code

KB8P / 60 - 78 - 15 - 30 - D - (S)

Type / Size

Length
L

ØD1
(H7)

ØD2
(f7)

Plug System

Options

Size	Torque TKN (Nm)	Dimensions (mm)									Technical Data								
		L Length	Ø A Outer Ø	D1 Bore Size (H7) min-max	D2 (f7) min-max	H	C	E2	E1	F/G Screw (ISO4762) TA (Nm)	Mass (kg)	Moment of Inertia J (g m²)	Spring Stiffness			Misalignment		max. speed (min-1)	
												torsional CT 10³ (Nm/rad)	radial CR (N/mm)	axial CA (N/mm)	radial ΔKr (mm)	axial ΔKa (mm)	angular ΔKw (°)		
18	18	47.5	45	10-24	13-25	17	5.5	12	20	M5	0.18	0.04	20	205	50	0.2	0.5	1.5	12800
		54.5								8	0.19	0.05	15	82	36	0.25	0.5	2	12800
30	30	59.5	56	10 32	14-30	20	7.3	17	25	M6	0.33	0.15	38	720	50	0.15	0.6	1.5	10300
		67.5		#30						15	0.34	0.16	28	225	28	0.25	1.0	2	10300
60	60	68	66	12-35	23-38	23	8.6	21	27	M8	0.49	0.28	75	1150	90	0.15	0.6	1.5	8700
		78								40	0.51	0.31	50	340	50	0.25	1.0	2	8700
150	150	75	82	14-44	26-42	28	9.8	21.5	32	M10	0.87	0.90	155	2020	145	0.2	0.5	1.5	6900
		87								84	0.92	0.95	105	595	85	0.25	0.8	2	6900
300	300	93	110	20-60	38-60	39	10.8	27	45	M12	1.87	3.28	502	6300	280	0.2	0.5	1.5	6000
		107								145	1.91	3.37	285	1400	145	0.25	0.8	2	6000



Material

bellows - stainless steel
collet clamps - aluminium
expanding clamps - steel

Hub

bore tolerance: H7

Temperature Range

-30 °C ~ 120 °C

Keyway

optional acc. DIN 6885
biggest bore marked with a #

Size	Dimensions (mm)			
	L1	L2	L3	V
18	33.5	14	22	0.5-1.0
	40.5			
30	40.5	19	31	0.5-1.0
	48.5			
60	45	23	35	0.5-1.5
	55			
150	51.5	23.5	37.5	0.5-1.5
	63.5			
300	64	29	47	0.5-1.5
	78			

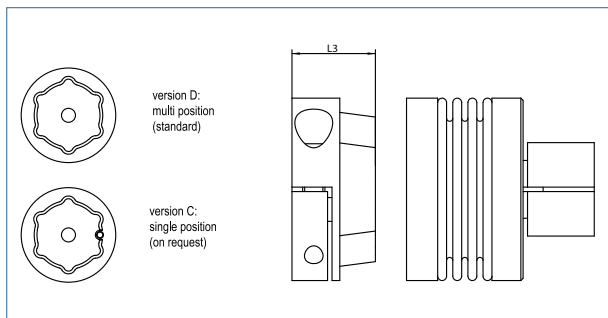

SERVO INSERT COUPLINGS

KBE1 | 5 ~ 48

Servo Insert Coupling
with set screws



P. 32

KBE2 | 5 ~ 19

Servo Insert Coupling
with collet clamps



P. 33

KBE2 | 24 ~ 48

Servo Insert Coupling
with collet clamps



P. 34

KBE2C | 7 ~ 48

Servo Insert Coupling
with collet clamps, compact



P. 35

KBE2H | 14 ~ 48

Servo Insert Coupling
with split hubs



P. 36

KBE2HC | 14 ~ 48

Servo Insert Coupling
with split hubs



P. 37

KBE2D | 7 ~ 38

Servo Insert Coupling
doublecardanic with collet clamps



P. 38

KBE3 | 14 ~ 48

Servo Insert Coupling
with outer conical hubs



P. 39

KBE3C | 14 ~ 48

Servo Insert Coupling
with outer conical hubs, compact



P. 40

KBE4 | 14 ~ 38

Servo Insert Coupling
with expanding clamps



P. 41

Servo Insert Coupling

with set screws

optional full stainless steel version

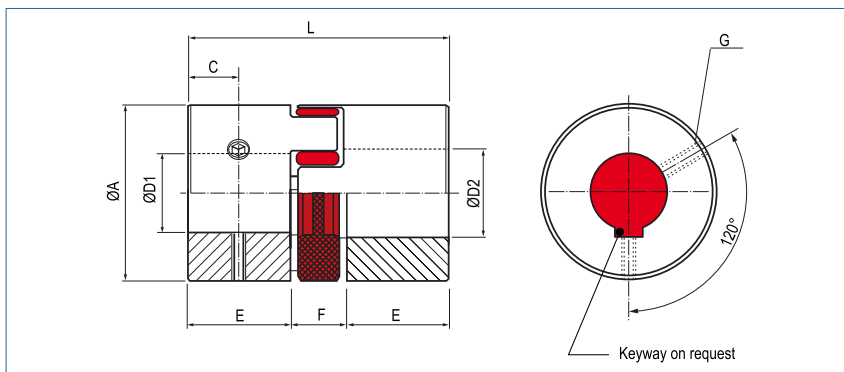
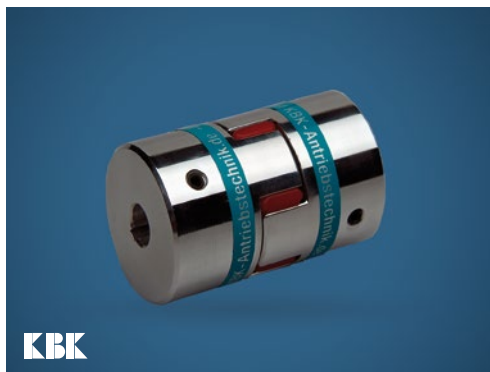

Order Code

KBE1 - 14 - 10 - 12 - 98Sh

Type Size ØD1 (H7) ØD2 (H1) Shore-hardness

Size	Dimensions (mm)							Technical Data			
	Ø A Outer Ø	L Length	Ø D1-D2 Bore Sizes (H7) min-max	E	F	C	F Screw (ISO4029) TA (Nm)	max. speed rpm. (1/min)	Mass (per coupling) (g)	Moment of Inertia (per coupling) J (g m²)	Torque (Nm)
5	10	15	2 - 6	5	5	2.5	1 x M3 0.5	47500	2.62	0.0000216	0.5
7	14	22	4 - 7	7	8	3.5	2 x M3 1.3	34000	6.5	0.00018	1.2
9	20	30	6 - 9	10	10	5	2 x M3 1.3	24000	22	0.00105	3
14	30	35	6 - 16	11	13	5	1 x M4 3	16000	45	0.006	12.5
19	40	66	10 - 24	25	16	10	1 x M5 6	12000	187	0.040	17
24	55	78	16 - 28	30	18	10	1 x M5 6	8500	420	0.171	60
28	65	90	20 - 38	35	20	15	1 x M6 11	7200	577	0.368	160
38	80	114	20 - 45	45	24	15	1 x M8 25	6000	1200	1125	325
42	95	126	20 - 55	50	26	20	1 x M8 25	4800	1850	16103	450
48	105	140	20 - 60	56	28	20	1 x M8 25	4300	2562	4124	525



Material hub - aluminium
 spider element - polyurethane
Hub bore tolerance: H7
Keyway optional acc. DIN 6885
Shore-hardness to size 9: 92 Sh A (yellow)
 from size 14: 98 Sh A (red)
 Further spider elements and technical data are available on page 42.

Servo Insert Coupling

with collet clamps

optional full stainless steel version

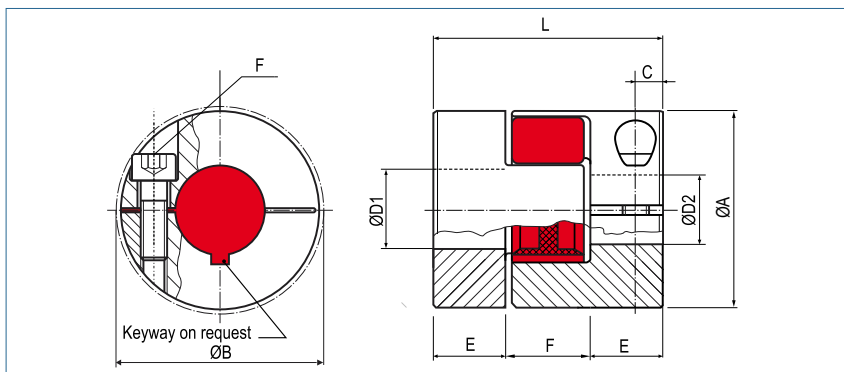

Order Code

KBE2 - 14 - 10 - 12 - 98Sh

Type Size ØD1 (H7) ØD2 (H7) Shore-hardness

Size	Dimensions (mm)								Technical Data			
	ØA Outer Ø	L Length	Ø D1-D2 Bore Sizes (H7) min-max	E	F	C	B	F Screw (ISO4762) TA (Nm)	max. speed rpm. (1/min)	Mass (per coupling) (g)	Moment of Inertia (per coupling) J (g m²)	Torque (Nm)
5	10	15	2 - 5	5	5	2.5	11.4	M1.6 0.25	38000	2.52	0.000036	0.5
7	14	22	4 - 7	7	8	3.5	15	M2 0.43	27000	7	0.000195	1.2
9	20	30	4 - 11	10	10	5	23.4	M2.5 0.85	19000	18.52	0.00107	3
14	30	35	4 - 16	11	13	5	32.2	M3 2	13000	59	0.00381	12.5
19	40	66	10 - 22/24*	25	16	12	47	M6 15	10000	183	0.0404	17

Ø Bore Size (mm)																							
Size	2	3	4	5	6	7	8	9	10	11	12	13	14	15	16	17	18	19	20	21	22		
5	06	0.6	0.7	0.8																			
7			1.3	1.4	1.5	1.6																	
9			2.3	2.4	2.5	2.7	2.8	2.9	3.0	3.2													
14			7.7	8.0	8.3	8.6	8.9	9.2	9.4	9.7	10	10.3	10.6	10.9	11.2								
19											44	45	47	48	49	50	51	52	54	55	56	57	58

+ **Material** hub - aluminium
 spider element - polyurethane
Hub bore tolerance: H7
Keyway optional acc. DIN 6885
Shore-hardness bis size 9: 92 Sh A (yellow)
 ab size 14: 98 Sh A (red)

* Hubs for bores > 22H7 to 24H7 will be supplied with 2 x M4 screws.
 Further spider elements and technical data are available on page 42.

Servo Insert Coupling

with collet clamps

optional full stainless steel version

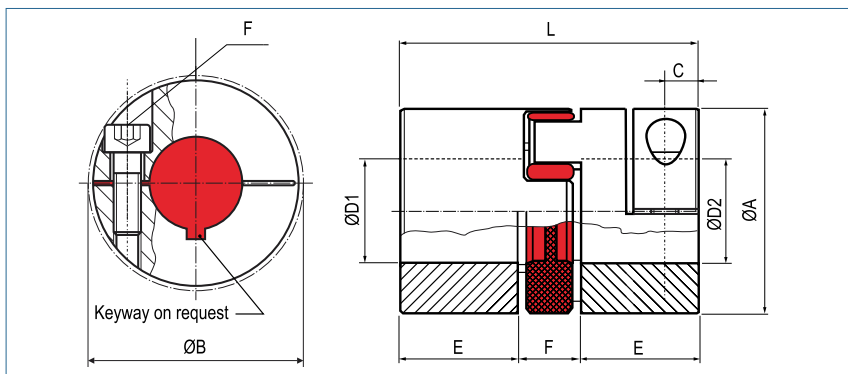

Order Code

KBE2 - 38 - 20 - 40 - 98Sh

Type Size ØD1 (H7) ØD2 (H7) Shore-hardness

Size	Dimensions (mm)							Technical Data				
	ØA Outer Ø	L Length	Ø D1-D2 Bore Sizes (H7) min-max	E	F	C	B	F Screw (ISO4762) TA (Nm)	max. speed rpm. (1/min)	Mass (per coupling) (g)	Moment of Inertia J (per coupling) (g m²)	Torque (Nm)
24	55	78	15 - 32	30	18	12	56.4	M6 15	7000	394	0.175	60
28	65	90	19 - 37	35	20	15	72.6	M8 40	6000	624	0.377	160
38	80	114	20 - 48	45	24	20	83.3	M8 40	5000	1230	1.139	325
42	95	126	25 - 50	50	26	20	95	M10 84	4000	1960	2.505	450
48	105	140	25 - 57	56	28	22	105	M12 145	3750	2690	4.175	525

Size	Ø Bore Size (mm)																											
	15	16	19	20	22	24	25	28	30	32	35	38	39	40	41	42	43	44	45	46	47	48	49	50	51	52	53	54
24	64	65	69	70	72	74	76	79	81	84																		
28			114	116	119	123	124	130	133	137	142																	
38				135	138	142	144	149	152	156	161	166	168	169	171	173	175	176	178									
42							294	304	310	317	327	337	340	343	347	350	353	357	360	363	367	370	373	376				
48							476	491	500	510	524	539	544	548	553	558	563	568	572	577	582	587	592	596	601	606	611	616

+ **Material** hub - aluminium
 spider element - polyurethane
Hub bore tolerance: H7
Keyway optional acc. DIN 6885
Shore-hardness 98 Sh A (red)
 Further spider elements and technical data are available on page 42.

Servo Insert Coupling

with collet clamps, compact

optional full stainless steel version

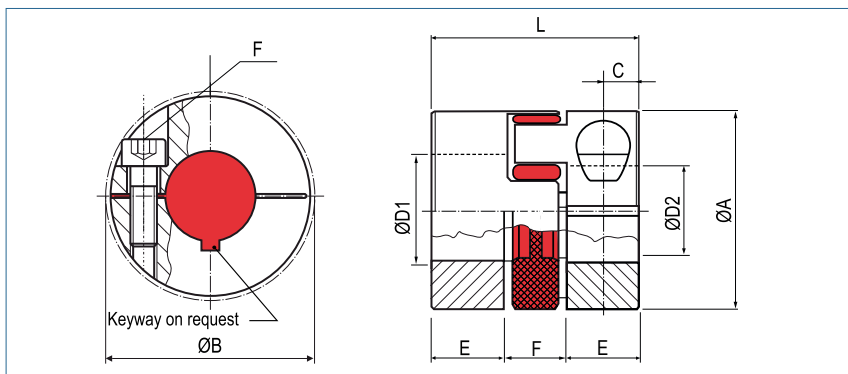

Order Code

KBE2C - 38 - 20 - 40 - 98Sh

Type Size ØD1 (H7) ØD2 (H7) Shore-hardness

Size	Dimensions (mm)								Technical Data			
	Ø A Outer Ø	L Length	Ø D1-D2 Bore Sizes (H7) min-max	E	F	C	B	G Screw (ISO4762) TA (Nm)	max. speed rpm. (1/min)	Mass (per coupling) (g)	Moment of Inertia J (per coupling)	Torque (Nm)
7	14	18	3 - 7	5	8	2.5	16.6	M2 0.43	27000	6	0.00018	1.2
9	20	24	4 - 11	7	10	3.5	21.3	M2.5 0.85	19000	15	0.00085	3
14	30	32	4 - 16	9.5	13	5	30.5	M4 4.5	13000	45	0.0166	12.5
19	40	50	8 - 21	17	16	8.5	45.7	M6 15	10000	139	0.0311	17
24	55	58	10 - 32	20	18	10	56.4	M6 15	7000	271	0.119	60
28	65	62	14 - 37	21	20	11	72.6	M8 40	6000	429	0.254	160
38	80	86	15 - 48	31	24	15	83.3	M10 84	5000	888	0.828	325
42	95	94	20 - 50	34	26	17.5	97.6	M12 145	4000	1425	1.866	450
48	105	110	20 - 57	47.5	28	23	105	M12 145	3750	2019	3.221	525

Size	Ø Bore Size (mm)																									
	3	4	6	8	10	12	14	15	16	18	19	20	24	25	28	30	32	35	38	40	42	45	48	50	55	
7	1.2	1.3	1.5																							
9		2.3	2.5	2.8	3.0																					
14			14	14.7	15.7	16.7	17.7	18.3	18.8																	
19				42	44	47	49	50	51	54	55	56														
24					58	61	63	64	65	67	69	70	74	76	79	81	84									
28							105	107	109	112	114	116	123	124	130	133	137	142	147							
38								241	244	251	254	258	271	274	284	291	297	307	317	324	330	340	350			
42													452	457	471	481	491	505	519	529	539	553	568	577		
48													471	476	491	500	510	524	539	548	558	572	587	596	620	

+ **Material** hub - aluminium
 spider element - polyurethane
Hub bore tolerance: H7
Keyway optional acc. DIN 6885
Shore-hardness 98 Sh A (red)
 Further spider elements and technical data are available on page 42.

Servo Insert Coupling

with split hubs

optional full stainless steel version

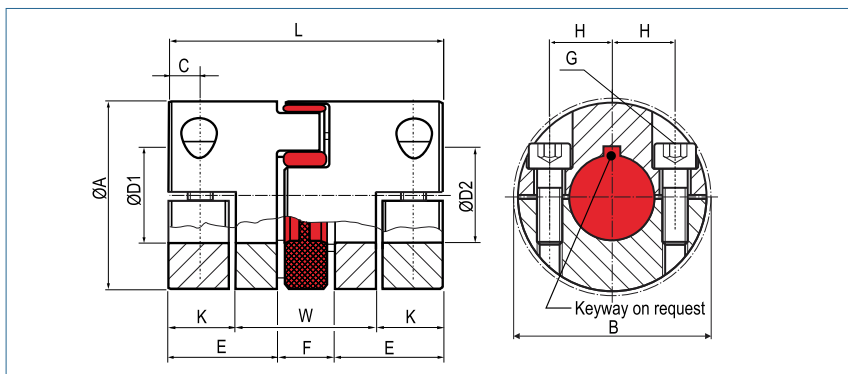
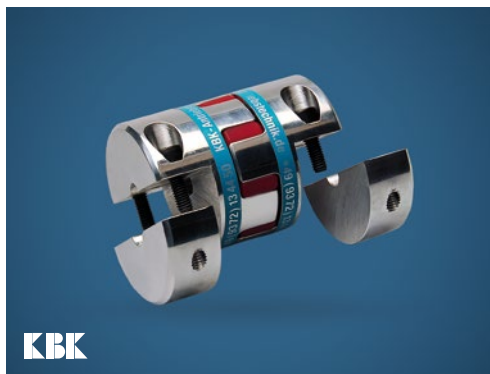

Order Code

KBE2H - 19 - 10 - 12 - 98Sh

Type Size ØD1 (H7) ØD2 (H7) Shore-hardness

Size	Dimensions (mm)											Technical Data				
	Ø A Outer Ø	L Length	Ø D1/D2 Bore Sizes		E	W	F	C	B	H	K	G Screw (ISO4762) TA (Nm)	max. speed rpm. (1/min)	Mass (per coupling) (g)	Moment of Inertia J (per coupling) (g m²)	Torque (Nm)
			min	max												
14	30	35	4	16	11	19	13	5.0	35	10.5	8	M4 5	13000	50	0,007	12.5
19	40	66	8	21	25	27	16	8.0	46	14.5	19.5	M6 15	10000	182	0,042	17
24	55	78	10	32	30	34	18	10.5	57.5	20	22.0	M6 15	7000	391	0,171	60
28	65	90	14	37	35	40	20	11.5	73	25	25.0	M8 40	6000	643	0,402	160
38	80	114	18	48	45	48	24	15.5	83.5	30	33.0	M8 40	5000	1167	1,096	325
42	95	126	22	50	50	53	26	18.0	93.5	32	36.5	M10 84	4000	1943	2,522	450
48	105	140	22	57	56	61	28	18.5	105	36	39.5	M12 145	3750	2592	4,076	525

Size	Ø Bore Size (mm)																										
	4	6	8	10	11	14	15	16	18	19	20	22	24	25	28	30	32	35	38	40	42	45	46	48	50	55	
14	10.3	15.5	20.7	25.8	28.4	36.1	38.7	41.3																			
19			47	59	65	83	89	95	107	113	119																
24				59	65	83	89	95	107	113	119	130	142	148	166	178	190										
28						123	132	141	159	167	176	194	211	220	247	264	282	308									
38									159	167	176	194	211	220	247	264	282	308	335	352	370	396	405	423			
42												370	404	420	471	505	538	589	639	673	706	757	774	807	841		
48												539	588	612	686	735	784	857	931	980	1029	1102	1127	1176	1225	1347	

- Material hub - aluminium
 spider element - polyurethane
- Hub bore tolerance: H7
- Keyway optional acc. DIN 6885
- Shore-hardness 98 Sh A (red)
- Further spider elements and technical data are available on page 42.

Servo Insert Coupling

with split hubs

optional full stainless steel version

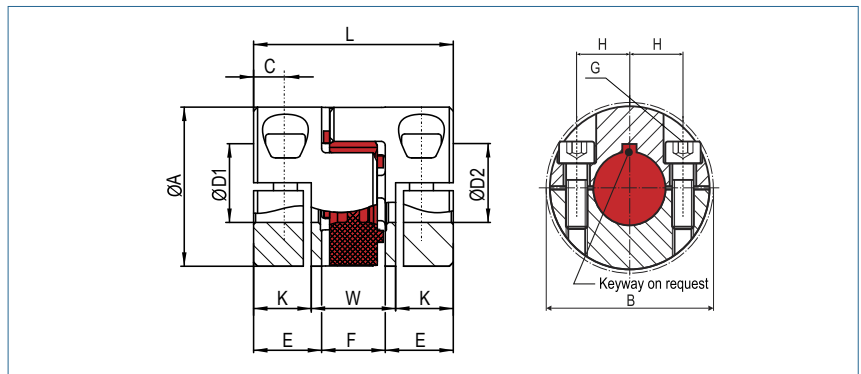

Order Code

KBE2HC - 19 - 10 - 12 - 98Sh

Type Size ØD1 (H7) ØD2 (H7) Shore-hardness

Size	Dimensions (mm)											Technical Data				
	Ø A Outer Ø	L Length	Ø D1/D2 Bore Sizes		E	W	F	K	C	B	H	G Screw (ISO4762) TA (Nm)	max. speed rpm. (1/min)	Mass (per coupling) (g)	Moment of Inertia (per coupling) J (g m ²)	Torque (Nm)
			min	max												
14	30	32	4	16	9.5	16.4	13	7.8	4.5	35	10.5	M4 4.5	13000	47	0.006	12.5
19	40	50	8	21	17	21	16	14.5	8.0	46	14.5	M6 15	10000	79	0.019	17
24	55	58	10	32	20	26	18	16	8	57.5	20	M6 15	7000	280	0.121	60
28	65	62	14	37	21	28	20	17	9	73	25	M8 40	6000	421	0.266	160
38	80	86	18	48	31	38	24	24	12	83.5	30	M8 40	5000	840	0.790	325
42	95	94	22	50	34.5	44	25	25	12.5	93.5	32	M10 84	4000	1416	1.832	450
48	105	110	22	57	41	50	28	30	14	105	36	M12 145	3750	1956	3.101	525

Size	Ø Bore Size (mm)																									
	4	6	8	10	11	14	15	16	18	19	20	22	24	25	28	30	32	35	38	40	42	45	46	48	50	55
14	10.3	15.5	20.7	25.8	28.4	36.1	38.7	41.3																		
19			47	59	65	83	89	95	107	113	119															
24				59	65	83	89	95	107	113	119	130	142	148	166	178	190									
28						123	132	141	159	167	176	194	211	220	247	264	282	308	335							
38									159	167	176	194	211	220	247	264	282	308	335	352	370	396	405	423		
42												370	404	420	471	505	538	589	639	673	706	757	774	807	841	
48												539	588	612	686	735	784	857	931	980	1029	1102	1127	1176	1225	1347

- Material** hub - aluminium
 spider element - polyurethane
- Hub** bore tolerance: H7
- Keyway** optional acc. DIN 6885
- Shore-hardness** 98 Sh A (red)
- Further spider elements and technical data are available on page 42.**

Servo Insert Coupling

doublecardanic with collet clamps

optional full stainless steel version

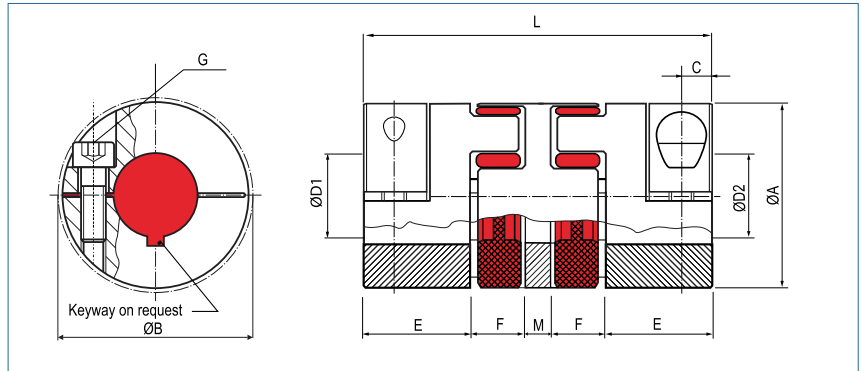

Order Code

KBE2D - 14 - 10 - 12 - 98Sh

Type Size ØD1 (H7) ØD2 (H7) Shore-hardness

Size	Dimensions (mm)									Technical Data			
	ØA Outer Ø	L Length	Ø D1-D2 Bore Sizes (H7) min~max	E	F	C	B	G Screw (ISO4762) TA (Nm)	M	max. speed rpm. (1/min)	Mass (per coupling) (g)	Moment of Inertia J (per coupling) (g m ²)	Torque (Nm)
7	14	34	4 - 7	7	8	3.5	15	M2 0.43	4	27000	5	0002	1.2
9	20	45	4 - 11	10	10	5	23.4	M2.5 0.85	5	19000	32	0.002	3
14	30	56	4 - 16	11	13	5	32.2	M3 2	8	13000	77	0.010	12.5
19	40	92	10 - 22/24*	25	16	12	45.7	M6 15	10	10000	232	0.056	17
24	55	112	15 - 32	30	18	14	56.6	M6 15	16	7000	534	0.188	60
28	65	128	19 - 37	35	20	15	70.2	M8 40	18	6000	844	0.507	160
38	80	158	20 - 48	45	24	20	82.5	M8 40	20	5000	1580	1.489	325

Size	Ø Bore Size (mm)																									
	4	5	6	7	8	9	10	11	12	14	15	16	19	20	22	24	25	28	30	32	35	38	40	42	45	
7	1.3	1.4	1.5	1.6																						
9	2.3	2.4	2.5	2.7	2.8	2.9	3.0	3.2																		
14	7.7	8.0	8.3	8.6	8.9	9.2	9.4	9.7	10	10.6	10.9	11.2														
19							44	45	47	49	50	51	55	56	58											
24										64	65	69	70	72	74	76	79	81	84							
28													114	116	119	123	124	130	133	137	142					
38															135	138	142	144	149	152	156	161	166	169	173	178

Material hub - aluminium
 spider element - polyurethane

Hub bore tolerance: H7

Keyway optional acc. DIN 6885

Shore-hardness to size 9: 92 Sh A (yellow)
 from size 14: 98 Sh A (red)

* Hubs for bores > 22H7 to 24H7 will be supplied with 2 x M4 screws.
 Further spider elements and technical rates are available on page 42.

Servo Insert Coupling

with outer conical hubs

optional full stainless steel version

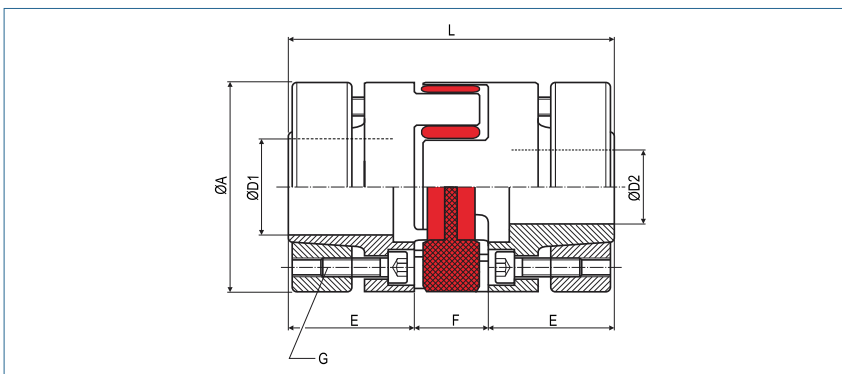

Order Code	KBE3	-	48	-	40	-	35	-	98Sh
	Type		Size		ØD1 (H7)		ØD2 (H7)		Shore-hardness

Size	Dimensions (mm)						Technical Data			
	Ø A Outer Ø	L Length	Ø D1-D2 Bore Sizes (H7) min~max	E	F	G Screw (ISO4762) TA (Nm)	max. speed rpm. (1/min)	Mass (per coupling) (g)	Moment of Inertia (per coupling) J (g m²)	Torque (Nm)
14	30	50	6 - 14	18.5	13	M3 1.34	25000	105	0.014	12.5
19	40	66	10 - 20	25	16	M4 2.9	19000	277	0.066	17
24	55	78	15 - 28	30	18	M5 6	14000	612	0.282	60
28	65	90	19 - 38	35	20	M5 6	12000	937	0.650	160
38	80	114	20 - 45	45	24	M6 10	10000	1961	2.005	325
42	95	126	28 - 50	50	26	M8 35	8000	3069	4.322	450
48	105	140	35 - 60	56	28	M8 35	7000	3855	6.851	525

Size	Ø Bore Size (mm)																						
	6	10	11	14	15	16	19	20	24	25	28	30	32	35	38	40	42	45	48	50	55		
14	8.6	13.8	14.7	22.7																			
19		41	45	62	68	67	83	90															
24					74	72	90	97	112	120	143												
28							189	188	237	250	280	307	310	353	389								
38								269	337	356	398	436	424	501	533	572	585	644					
42											445	506	470	566	581	647	630	728	836	858			
48														955	999	1092	1091	1230	1381	1334	1540		

- Material**
 - hub - aluminium
 - outer conical hub - Steel
 - spider element - polyurethane
- Hub**
 - bore tolerance: H7
- Shore-hardness**
 - 98 Sh A (red)
- Further spider elements and technical data are available on page 42.**

Servo Insert Coupling

with outer conical hubs, compact

optional full stainless steel version

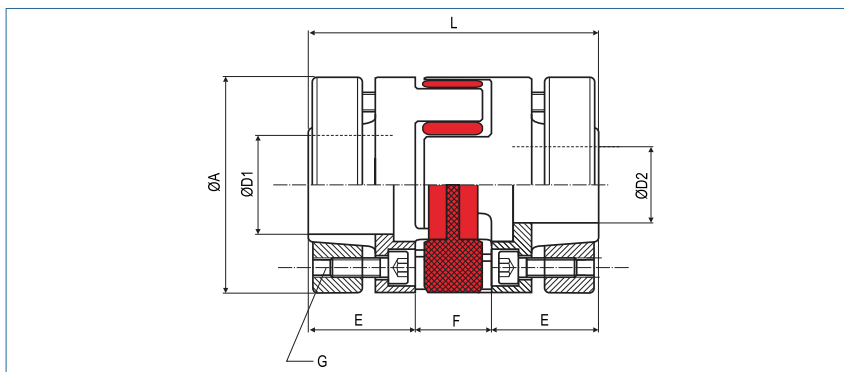

Order Code	KBE3C	- 48	- 40	- 35	- 98Sh
	Type	Size	ØD1 (H7)	ØD2 (H7)	Shore-hardness

Size	Dimensions (mm)						Technical Data			
	Ø A Outer Ø	L Length	Ø D1-D2 Bore Sizes (H7) min-max	E	F	G Screw (ISO4762) TA (Nm)	max. speed rpm. (1/min)	Mass (per coupling) (g)	Moment of Inertia (per coupling) J (g m ²)	Torque (Nm)
14	30	42	6 - 14	14.5	13	M3 1.34	25000	91	0.012	12.5
19	40	56	10 - 20	20	16	M4 3	19000	252	0.063	17
24	55	64	14 - 28	23	18	M5 6	14000	492	0.236	60
28	65	76	19 - 38	28	20	M5 6	12000	776	0.535	160
38	80	96	20 - 45	36	24	M6 10	10000	1639	1.686	325
42	95	103	28 - 50	38.5	26	M8 35	8000	2612	3.621	450
48	105	110	30 - 55	41	28	M8 35	7000	3105	5.465	525

Size	Ø Bore Size (mm)																					
	6	10	11	14	15	16	19	20	24	25	28	30	32	35	38	40	42	45	48	50	55	
14	5.4	7.5	11.3	24.7																		
19		17	20	41	49	36	56	64														
24				47	57	67	98	110	127	139	175											
28							121	133	201	219	248	285	253	307	329							
38								203	304	331	394	452	453	543	550	609	669	634				
42											444	508	535	638	692	763	754	858	964	976		
48												572	638	762	842	929	943	1074	1208	1136	1336	

+ **Material** hub - aluminium
outer conical hub - steel
spider element - polyurethane

Hub bore tolerance: H7

Shore-hardness 98 Sh A (red)

Further spider elements and technical data are available on page 42.

Servo Insert Coupling

with expanding clamps

optional full stainless steel version

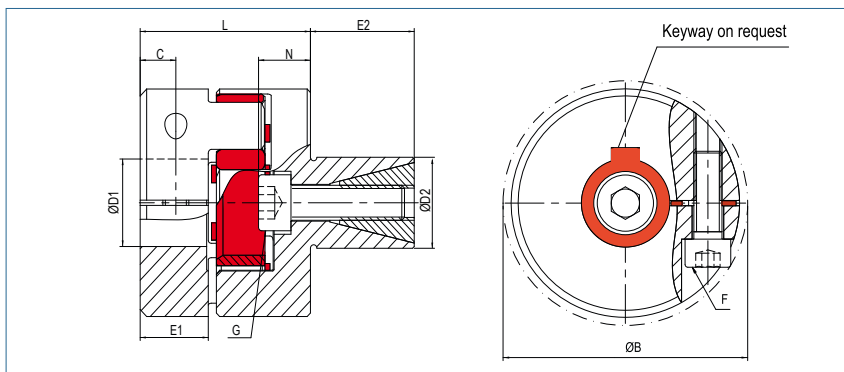

Order Code

KBE4 - 38 - 40 - 35 - 98Sh

Type Size ØD1 (H7) ØD2 (h7) Shore-hardness

Size	Dimensions (mm)											Technical Data			
	ØA Outer Ø	L	Ø D1 Bore Size (H7) min~max	Ø D2 (h7) min~max	E1	E2	N	C	B	F Screw (ISO4762) TA (Nm)	G Screw (ISO4762) TA (Nm)	max. speed upm. (1/min)	Mass (per coupling) (g)	Moment of Inertia (per coupling) J (g m ²)	Torque (Nm)
14	30	28	4 - 16	13 - 25	11	20	7	5	32.2	M3 2	M5 9	20000	98	0.010	12.5
19	40	40	10 - 22/24*	14 - 30	17	25	10	9	45.7	M6 15	M6 15	19000	240	0.042	17
24	55	46	12 - 32	23 - 36	20	27	11	10	56.4	M6 15	M8 40	14000	463	0.158	60
28	65	51	19 - 37	26 - 42	21	32	16	11	72.6	M8 40	M10 84	11500	799	0.375	160
38	80	68	20 - 48	38 - 60	31	45	20	15	83.3	M8 40	M12 145	9500	1754	1.213	325

Size	Ø Bore Size (mm)																						
	4	6	8	9	10	11	12	14	15	16	18	19	20	24	25	28	30	32	35	38	40	42	45
14	7.7	8.3	8.9	9.2	9.4	9.7	10	10.6	10.9	11.2													
19					44	45	47	49	50	51	54	55	56										
24							61	63	64	65	67	69	70	74	76	79	81	84					
28												114	116	123	124	130	133	137	142				
38													135	142	144	149	152	156	161	166	169	173	178

+ **Material** hub - aluminium
 expanding clamps - steel
 spider element - polyurethane

Hub bore tolerance: H7

Keyway optional acc. DIN 6885

Shore-hardness 98 Sh A (red)

* Hubs for bores > 22H7 to 24H7 will be supplied with 2 x M4 screws.
 Further spider elements and technical data are available on page 42.

Spider Elements for Couplings Type KBE

Type KBE series

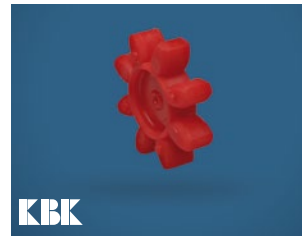

80 ShoreA
operating temperature:
-50 to +80
peak temperature: -60 to +120

92 ShoreA
operating temperature:
-30 to +90
peak temperature: -50 bis +120

98 ShoreA
operating temperature:
-30 to +90
peak temperature: -40 bis +120

64 ShoreD
operating temperature:
-20 to +110
peak temperature: -30 bis +120

Size	Hardness	Torque [Nm]		Torsional Stiffness Static [Nm/rad]	Torsional Stiffness Dynamic [Nm/rad]	Spring Stiffness radial [N/mm]	Misalignment			max. Bore [mm]
		TK nom.	TK max				axial [mm]	radial [mm]	angular [Grad]	
5	92 ShA	0.5	0.6	5.16	16	154	+0.4 / -0.2	0.06	1.0°	3
7	80 ShA	0.7	1.4	8.6	26	114	+0.6 / -0.3	0.15	1.1°	3
	92 ShA	1.2	2.4	14.3	43	219	+0.6 / -0.3	0.10	1.0°	
	98 ShA	2	4	22.9	69	421	+0.6 / -0.3	0.10	1.0°	
	64 ShD	2.4	4.8	34.3	103	630	+0.6 / -0.3	0.04	0.8°	
9	80 ShA	1.8	3.6	17.2	52	125	+0.8 / -0.4	0.2	1.1°	7
	92 ShA	3	6	31.5	95	262	+0.8 / -0.4	0.15	1.0°	
	98 ShA	5	10	51.6	155	518	+0.8 / -0.4	0.1	0.9°	
	64 ShD	6	12	74.6	224	739	+0.8 / -0.4	0.05	0.8°	
12	80 ShA	3	6	84.3	252	274	+0.9 / -0.4	0.20	1.1°	8
	92 ShA	5	10	160.4	482	470	+0.9 / -0.4	0.14	1.0°	
	98 ShA	9	18	240.7	718	846	+0.9 / -0.4	0.08	0.9°	
	64 ShD	12	24	327.9	982	1198	+0.9 / -0.4	0.05	0.8°	
14	80 ShA	4	8	60.2	180	153	+1.0 / -0.5	0.21	1.1°	10
	92 ShA	7.5	15	114.6	344	336	+1.0 / -0.5	0.15	1.0°	
	98 ShA	12.5	25	171.9	513	654	+1.0 / -0.5	0.09	0.9°	
	64 ShD	16	32	234.2	702	856	+1.0 / -0.5	0.06	0.8°	
19	80 ShA	6	12	618	1065	582	+1.2 / -0.5	0.15	1.1°	18
	92 ShA	12	24	1090	1815	1120	+1.2 / -0.5	0.10	1.0°	
	98 ShA	21	42	1512	2540	2010	+1.2 / -0.5	0.06	0.9°	
	64 ShD	26	52	2560	3810	2930	+1.2 / -0.5	0.04	0.8°	
24	80 ShA	17	34	860	1390	840	+1.4 / -0.5	0.2	1.0°	27
	92 ShA	35	70	2300	5130	1900	+1.4 / -0.5	0.15	1.0°	
	98 ShA	60	120	3700	8130	2940	+1.4 / -0.5	0.11	0.9°	
	64 ShD	75	150	5030	11500	4200	+1.4 / -0.5	0.08	0.8°	
28	80 ShA	46	92	1370	2350	990	+1.5 / -0.7	0.2	1.3°	30
	92 ShA	95	190	4080	6745	1780	+1.5 / -0.7	0.15	1.0°	
	98 ShA	160	320	6410	9920	3200	+1.5 / -0.7	0.11	0.9°	
	64 ShD	200	400	10260	20177	4348	+1.5 / -0.7	0.08	0.8°	
38	92 ShA	190	380	6525	12000	2350	+1.8 / -0.7	0.17	1.0°	38
	98 ShA	325	650	11800	21850	4400	+1.8 / -0.7	0.12	0.9°	
	64 ShD	405	810	26300	40335	6474	+1.8 / -0.7	0.09	0.8°	
42	92 ShA	265	530	10870	20500	4100	+2.0 / -1.0	0.19	1.0°	46
	98 ShA	450	900	21594	37692	5940	+2.0 / -1.0	0.14	0.9°	
	64 ShD	560	1120	36860	71400	7590	+2.0 / -1.0	0.10	0.8°	
48	92 ShA	310	620	12968	22800	4500	+2.1 / -1.0	0.23	1.0°	51
	98 ShA	525	1050	25759	49400	6820	+2.1 / -1.0	0.16	0.9°	
	64 ShD	655	1310	57630	102800	9000	+2.1 / -1.0	0.11	0.8°	

CARDAN COUPLINGS

KBGK | 18 ~ 100

Linear Coupling
with threads



P. 44

KBGK-T | 18 ~ 100

Cardan Coupling
with collet clamps



P. 45

LINE SHAFTS

DRE | 14 ~ 48

Line Shaft
split hubs and servo inserts



P. 46

DRB | 4.5 ~ 500

Line Shaft
with split hubs and metal bellows



P. 47

RIGID SHAFT COUPLINGS

KBST

Rigid Shaft Coupling
single slit



P. 48

KBST - VA

Rigid Shaft Coupling
single slit, in stainless steel



P. 49

KBST - G

Rigid Shaft Coupling
split



P. 50

KBST - G - VA

Rigid Shaft Coupling
split, in stainless steel



P. 51

Cardan Coupling

Linear Coupling with threads

optional full stainless steel

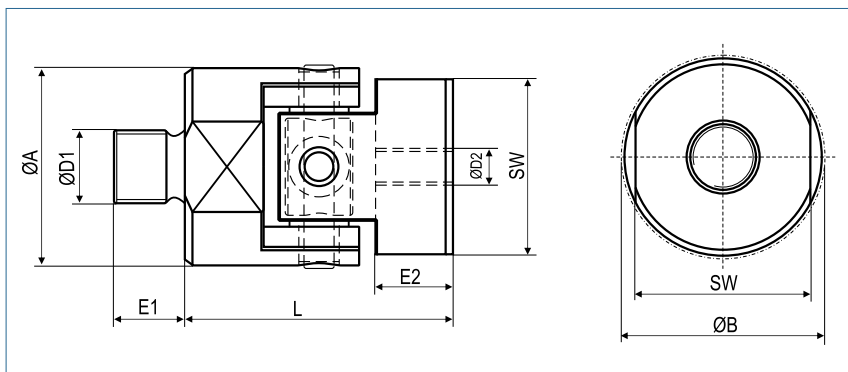

Order Code

KBGK / 27 - M5 - M6

Type / Size

Thread
Ø D1

Thread
Ø D2

Size	axial force F_{KA} (N)	Dimensions (mm)					Technical Data					
		L Length	Ø A Outer Ø	SW wrench Size	E2 max. thread depth	B	Mass (kg)	Moment of Inertia J (kg mm ²)	Spring Stiffness axial CA (N/mm)	Misalignment		max. speed rpm
									radial ΔKr (mm)	angular ΔKw (°)		
18	200	24	18	16	5.5	19	0.013	0.52	8500	1	6	10000
27	800	36	27	24	10.5	30	0.046	4.25	14800	1	6	7500
35	1000	37	35	32	11	39	0.082	12.37	19000	1.5	6	6000
56	4000	60	56	50	15	61	0.31	121	33000	2	6	3750
75	7500	75	74.5	65	25	80	0.87	594	42800	2	6	2850
100	13000	78	100	90	27	106	1.83	2194	62000	2.5	6	2100

Size	Hub Style	Thread Size (transmittable axial force in N)													
		M3	M4	M5	M6	M8	M10	M12	M16	M20	M24	M30	M36	M42	M48
18	Thread D1	510	670	857	1017	1380									
	Thread Length E1	5	6	8	8	10									
	Thread D2	634	1105	1788	2531	4631									
27	Thread D1		670	857	1017	1380	1740								
	Thread Length E1		6	8	8	10	12								
	Thread D2	634	1105	1788	2531	4631	7313								
35	Thread D1					1380	1740	1970	2710						
	Thread Length E1					10	12	15	20						
	Thread D2			1788	2531	4631	7313	10603	9800						
56	Thread D1							1970	2710	3386	4064	5142			
	Thread Length E1							15	20	25	30	36			
	Thread D2					4631	7313	10603	9800	15400	22140	35344			
75	Thread D1									3386	4064	5142	6218		
	Thread Length E1									25	30	36	40		
	Thread D2						7313	10603	9800	15400	22140	35344	51390		
100	Thread D1											5142	6218	7296	8374
	Thread Length E1											36	40	48	55
	Thread D2							10603	9800	15400	22140	35344	51390	70484	92625

+ **Material** inner ring - aluminium
hub - aluminium
pin - steel

Temperature Range -100 °C ~ 250 °C

Cardan Coupling

with collet clamps

optional full stainless steel

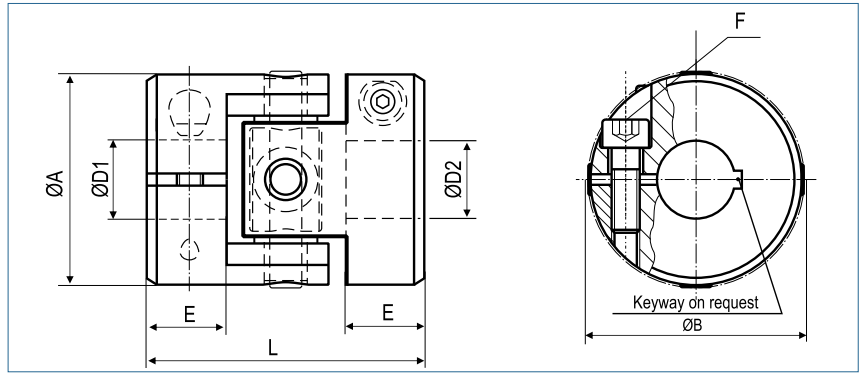

Order Code

KBGK-T / 27 - 6 - 10

Type / Size

ØD1
(H7)

ØD2
(H1)

Size	Torque T_{KN} (Nm)	Torque T_{kmax} (Nm)	Dimensions (mm)					Technical Data						
			L Length	Ø A Outer Ø	D1/D2 Bore Sizes (H7)	B	E Hub- Length	F Screw (ISO 4762) TA (Nm)	Mass (kg)	Moment of Inertia J (kg mm ²)	Torsional Stiffness CT (Nm/rad)	Misalignment		max. speed rpm
										radial ΔKr (mm)	angular ΔKw (°)			
18	2	3	24	18	3-10	19	5.5	M2	0.011	0.526	458	0.6	6	10000
								0.54						
27	5	10	36	27	4-14	30	10.5	M3	0.040	4.30	802	1	6	7500
								1.9						
35	10	18	37	35	5-20	39	11	M4	0.069	12.19	1701	1.5	6	6000
								4.6						
56	35	100	53	56	8-32	61	15	M6	0.278	124	20630	2	6	3750
								15.7						
75	100	250	83	74.5	10-41	80	25	M8	0.76	609	51575	2	6	2850
								38						
100	250	580	97	100	20-55	106	27	M12	1.60	2246	85943	2.5	6	2100
								130						

18	Bore Size	3	4	5	6	7	8	9	10			
	Torque (Nm)	1.9	2	2.2	2.3	2.4	2.5	2.6	2.8			
27	Bore Size	4	5	6	7	8	9	10	11	12	13	14
	Torque (Nm)	6.9	7.2	7.4	7.7	8	8.3	8.6	8.9	9.2	9.4	9.7
35	Bore Size	5	6	7	8	9	10	12	14	16	18	20
	Torque (Nm)	16	16.4	16.9	17.4	18	18.5	19.5	20.5	21.6	22.6	23.6
56	Bore Size	8	10	12	14	16	18	20	22	24	28	32
	Torque (Nm)	57	59	61	64	66	69	72	73	76	80	85
75	Bore Size	10	12	14	16	18	20	24	28	32	36	40
	Torque (Nm)	143	147	151	156	160	164	173	181	190	199	207
100	Bore Size	20	22	24	26	28	30	35	40	45	50	55
	Torque (Nm)	475	485	495	505	515	525	550	575	600	625	650



Material inner ring - aluminium
hub - aluminium
pin - steel

Temperature Range -100 °C ~ 250 °C

Line Shaft

with split hubs and servo inserts

optional laserwelded
optional full stainless steel version

optional with carbon tube

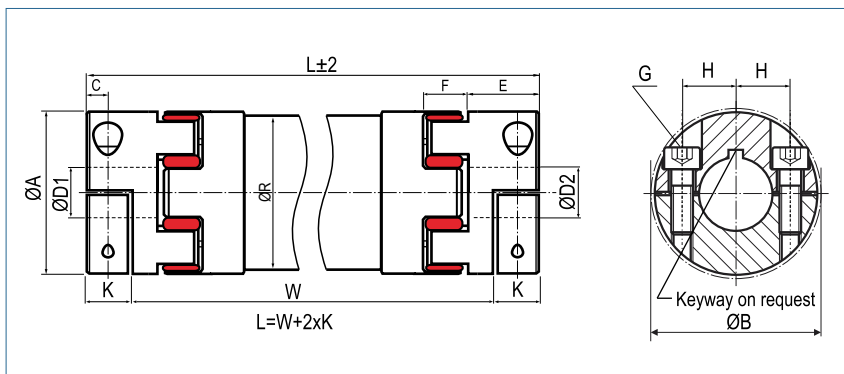

Order Code

DRE / 19 - 2000 - 10 - 16 - 98Sh

Type / Size

Length

ØD1 (H7)

ØD2 (H7)

Shore-hardness

Size	Dimensions (mm)											Technical Data				
	Ø D1/D2		Ø A	E	K	F	L		R	B	C	H	G (ISO4762)	TKN (Nm)	TKmax (Nm)	CT/m (Nm/rad)
	Bore Sizes (H7)						min	max								
min	max	Outer Ø														
14	4	16	30	11	8	13	102	3000	30	34	5	10.5	M4 5	12.5	25	500
19	8	21	40	25	19.5	16	133	3000	35	46	8.0	14.5	M6 15	17	34	1770
24	10	32	55	30	22.0	18	157	3000	50	57.5	10.5	20	M6 15	60	120	6400
28	14	37	65	35	25.0	20	181	3000	60	73	11.5	25	M8 40	160	320	11400
38	18	48	80	45	33.0	24	229	3000	75	83.5	15.5	30	M8 40	325	650	23000
42	22	50	95	50	36.5	26	253	3000	100	93.5	18.0	32	M10 84	450	900	194000
48	22	57	105	56	39.5	28	281	3000	100	105	18.5	36	M12 145	525	1050	194000

Size	Ø Bore (mm)																									
	4	6	8	10	11	14	15	16	18	19	20	22	24	25	28	30	32	35	38	40	42	45	46	48	50	55
14	10.3	15.5	20.7	25.8	28.4	36.1	38.7	41.3																		
19			47	59	65	83	89	95	107	113	119															
24				59	65	83	89	95	107	113	119	130	142	148	166	178	190									
28						123	132	141	159	167	176	194	211	220	247	264	282	308	335							
38								159	167	176	194	211	220	247	264	282	308	335	352	370	396					
42											370	404	420	471	505	538	589	639	673	706	757	774	807	841		
48											539	588	612	686	735	784	857	931	980	1029	1102	1127	1176	1225	1347	

Material hub: aluminium
spider element: polyurethane 98 Sh A (red)
tube: aluminium

Hub bore tolerance: H7

Keyway optional acc. DIN 6885

Longer versions up to 6m on request!

Information about permissible misalignments and maximum speeds are available in our assembly - instructions.

Line Shaft

with split hubs and metal bellows

optional laserwelded
optional full stainless steel version

optional with carbon tube

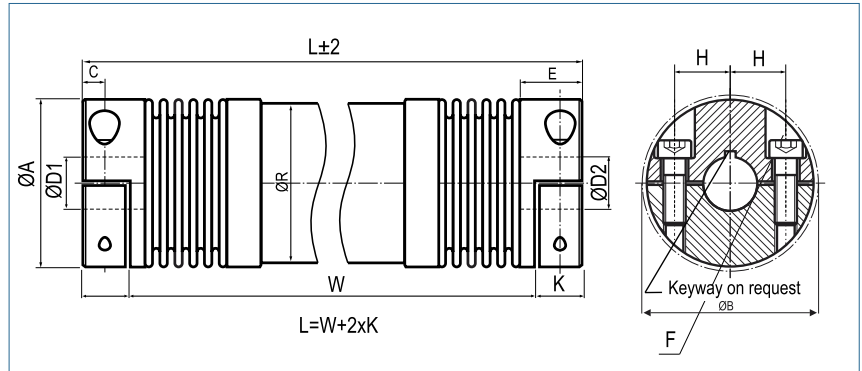

Order Code

DRB / 60 - 2000 - 15 - 20 - (S)

Type / Size

Length

ØD1 (H7)

ØD2 (H7)

Options

Size	Torque TKN (Nm)	Dimensions (mm)										Technical Data		
		L		Ø A	D1/D2	H	C	E	K	F	R	B	Spring Stiffness	
		min	max	Outer Ø	Bore Sizes (H7)					Screw (ISO4762) TA (Nm)	Tube Ø	Ø	Torsion Bellows $C_t \cdot 10^3$ (Nm/rad)	Torsion Shaft $C_t \cdot 10^3$ (Nm/rad)
4.5	4.5	68	3000	32.5	6-16	12	5	14	8.5	M4 35	30	34	3.2	0.5
10	10	82	3000	40.5	6-25	15.5	5	14	9	M4 45	35	41.5	4.1	1.8
18	18	108	3000	45	10-25.4	17	5.5	19.5	13	M5 8	35	47.4	10	1.8
30	30	111	3500	56	10-30	20	7.5	27	17	M6 15	50	56.4	19	6.5
60	60	135	4000	66	12-35	23	9.5	31	21	M8 40	60	66	37.5	11.5
150	150	154	4000	82	14-44	28	11	36	23.5	M10 84	75	82.9	77.5	23
200	200	169	4000	90	16-48	31	12.5	41	27	M12 125	90	90.8	87.5	73
300	300	179	4000	110	20-60	39	13	43	28	M12 145	100	110	251	194
500	500	215	4000	122	25-65	42	15	51	35.5	M12 145	100	122	345	194



Material bellows - stainless steel
hub - aluminium
tube - aluminium

Keyway optional acc. DIN 6885

Temperature Range -30 °C ~ 120°C

Longer versions up to 6m on request!

Bellows fail protect system is automatically integrated.

Information about permissible misalignments and maximum speeds are available in our assembly - instructions.

Rigid Shaft Coupling

single slit

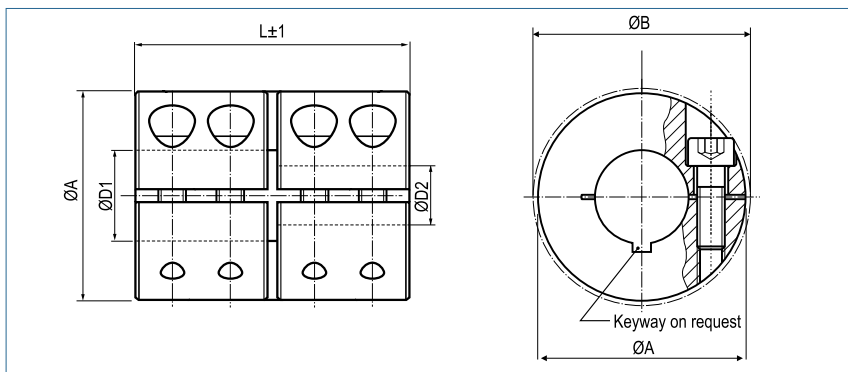

Order Code for Standard Coupling

KBST - 50

This coupling will automatically be supplied with unique bore 50H7.

Type Size

Order Code for Coupling with different Bore Diameters

KBST - 50 - 45 - 48

This coupling will be supplied with the dimensions of type KBST-50 but with a bore combination 45H7 - 48H7.

Type Size D1 D2

Rigid shaft coupling - Steel blackened									
Size	Torque Steel Nm	Dimensions					Screw (ISO4762)	Tightening Torque Screws Nm	Mass g
		Standard Bore D1 / D2 H7	different Bores min-max	A mm	B mm	L mm			
6	30	6	5-7	18	21.2	30	M3x8	2	47
8	50	8	5-12	24	26.8	35	M3x10	3	102
10	100	10	5-15	29	32.7	45	M4x12	4.5	185
12	100	12	5-15	29	32.7	45	M4x12	4.5	180
14	190	14	10-17	34	39.1	50	M5x16	9	272
15	190	15	10-17	34	39.1	50	M5x16	9	266
16	190	16	10-17	34	39.1	50	M5x16	9	261
20	350	20	10-24	42	48.2	65	M6x16	15	518
25	390	25	10-26	45	50.8	75	M6x16	15	623
30	475	30	20-32	53	58.1	83	M6x18	15	920
35	1100	35	20-40	67	74.1	95	M8x25	40	1880
40	1325	40	30-50	77	83.4	108	M8x25	40	2710
50	2250	50	40-52	85	93.2	124	M10x25	84	3520

Ø Bore (mm)																							
Size	5	6	8	10	12	14	16	18	20	22	24	26	28	30	32	34	36	38	40	44	46	48	50
6	18	19																					
8	25	26	29	31	33																		
10	51	53	57	61	65	69																	
12	51	53	57	61	65	69																	
14				109	116	122	129																
15				109	116	122	129																
16				109	116	122	129																
20				195	205	214	223	233	242	251	261												
25				209	219	228	237	247	256	265	275	284											
30									284	293	303	312	321	330	340								
35									582	599	616	632	649	666	682	699	716	732	749				
40														749	765	782	799	815	832	865	882	899	915
50																			1400	1453	1479	1506	1532

+ Keyways according DIN 6885/1 are only possible in unique bore diameters.

Rigid Shaft Coupling

single slit in stainless steel

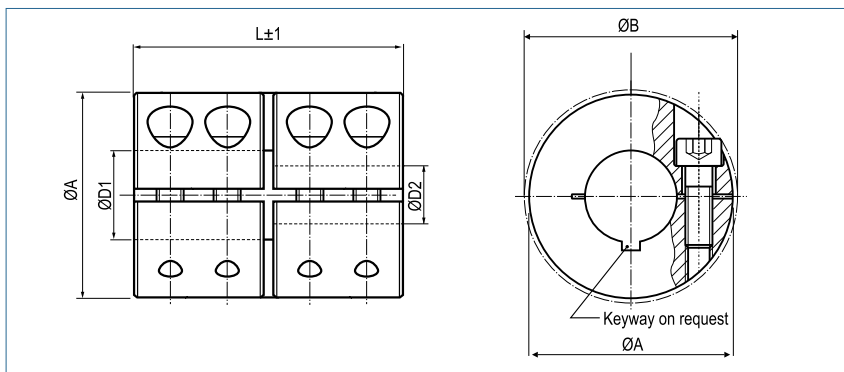

Order Code for Standard Coupling

KBST-VA - 50

This coupling will automatically be supplied with unique bore 50H7.

Type Size

Order Code for Coupling with different Bore Diameters

KBST-VA - 50 - 45 - 48

This coupling will be supplied with the dimensions of type KBST-50 but with a bore combination 45H7 - 48H7.

Type Size D1 D2

Rigid shaft coupling - Stainless Steel									
Size	Torque Stainless Steel Nm	Dimensions					Screw (ISO4762)	Tightening Torque Screws Nm	Mass g
		Standard Bore D1 / D2 H7	different Bores min~max	A mm	B mm	L mm			
6	25	6	5-7	18	21.2	30	M3x8	1.6	47
8	40	8	5-12	24	26.8	35	M3x10	1.6	102
10	90	10	5-15	29	32.7	45	M4x12	3.9	185
12	90	12	5-15	29	32.7	45	M4x12	3.9	180
14	160	14	10-17	34	39.1	50	M5x16	7.6	272
15	160	15	10-17	34	39.1	50	M5x16	7.6	266
16	160	16	10-17	34	39.1	50	M5x16	7.6	261
20	300	20	10-24	42	48.2	65	M6x16	13.2	518
25	325	25	10-26	45	50.8	75	M6x16	13.2	623
30	400	30	20-32	53	58.1	83	M6x18	13.2	920
35	925	35	20-40	67	74.1	95	M8x25	32	1880
40	1100	40	30-50	77	83.4	108	M8x25	32	2710
50	1875	50	40-52	85	93.2	124	M10x25	63	3520

Size	Ø Bore (mm)																				
	5	6	8	10	12	14	18	20	24	26	28	30	32	38	40	42	44	46	48	50	52
6	15	16																			
8	21	22	23	25	27																
10	44	45	49	52	56	59															
12	44	45	49	52	56	59															
14				93	98	104															
15				93	98	104															
16				93	98	104															
20				167	175	183	199	207	223												
25				179	187	195	211	219	235	243											
30								243	259	267	274	282	290								
35									510	539	553	568	582	597	641	655					
40												655	670	713	728	743	757	772	786	801	
50															1226	1250	1273	1296	1319	1342	1365

+ Keyways according DIN 6885/1 are only possible in unique bore diameters.

Rigid Shaft Coupling

split

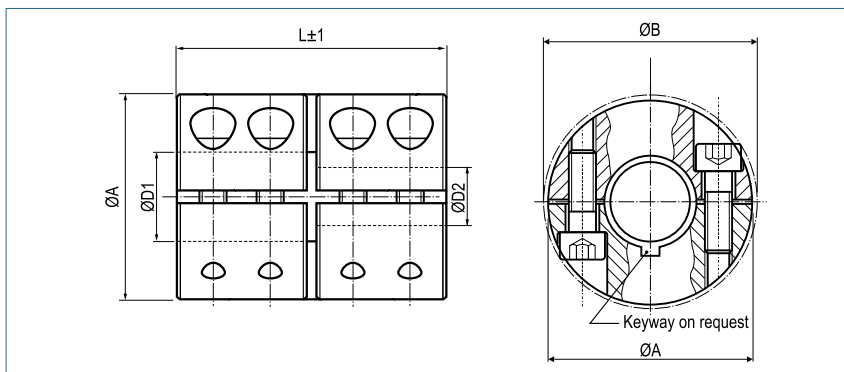

Order Code for Standard Coupling

KBST-G - 50

Type Size

This coupling will automatically be supplied with unique bore 50H7.

Order Code for Coupling with different Bore Diameters

KBST-G - 50 - 45 - 48

Type Size D1 D2

This coupling will be supplied with the dimensions of type KBST-50 but with a bore combination 45H7 - 48H7.

Rigid Shaft Coupling split - Steel blackened									
Size	Torque Steel Nm	Dimensions - Dimensions					Screws (ISO4762)	Tightening Torque Screws Nm	Mass g
		Standard Bore D1 / D2 H7	different Bores min~max	A mm	B mm	L mm			
6	30	6	5-7	18	21.2	30	M3x8	2	47
8	50	8	5-12	24	26.8	35	M3x10	3	102
10	100	10	5-15	29	32.7	45	M4x12	4.5	185
12	100	12	5-15	29	32.7	45	M4x12	4.5	180
14	190	14	10-17	34	39.1	50	M5x16	9	272
15	190	15	10-17	34	39.1	50	M5x16	9	266
16	190	16	10-17	34	39.1	50	M5x16	9	261
20	350	20	10-24	42	48.2	65	M6x16	15	518
25	390	25	10-26	45	50.8	75	M6x16	15	623
30	475	30	20-32	53	58.1	83	M6x18	15	920
35	1100	35	20-40	67	74.1	95	M8x25	40	1880
40	1325	40	30-50	77	83.4	108	M8x25	40	2710
50	2250	50	40-52	85	93.2	124	M10x25	84	3520

Ø Bore (mm)																					
Size	5	6	8	10	12	14	16	18	20	22	26	28	30	32	34	38	42	44	48	50	52
6	29	35																			
8	29	35	47	58	70																
10	52	62	83	103	124	145															
12	52	62	83	103	124	145															
14				168	202	235	269														
15				168	202	235	269														
16				168	202	235	269														
20				237	284	332	379	427	474	521											
25				237	284	332	379	427	474	521	616										
30									474	521	616	664	711	758							
35									847	932	1102	1186	1271	1356	1441	1610					
40													1271	1356	1441	1610	1780	1864	2034	2119	
50																	2825	2960	3229	3363	3498

+ Keyways according DIN 6885/1 are possible for all bore combinations.

Rigid Shaft Coupling

split, in stainless steel

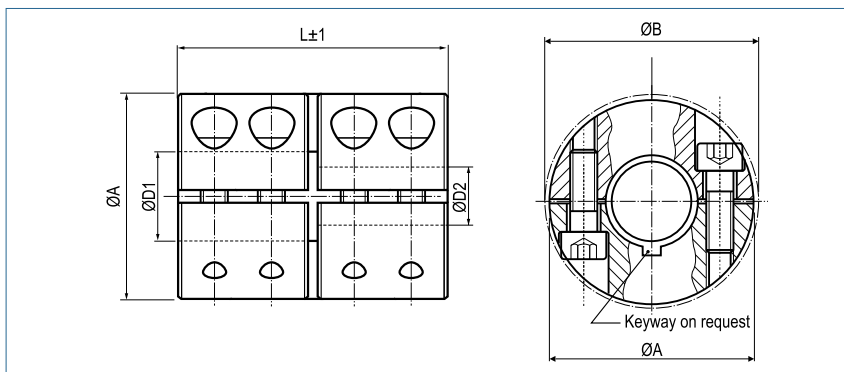

Order Code for Standard Coupling

KBST-G-VA - 50

This coupling will automatically be supplied with unique bore 50H7.

Type Size

Order Code for Coupling with different Bore Diameters

KBST-G-VA - 50 - 45 - 48

This coupling will be supplied with the dimensions of type KBST-50 but with a bore combination 45H7 - 48H7.

Type Size D1 D2

KBST - G - VA Rigid Shaft Coupling split - Stainless Steel									
Size	Torque Stainless Steel Nm	Dimensions					Screws (ISO4762)	Tightening Torque Screws Nm	Mass g
		Standard Bore D1 / D2 H7	different Bores min~max	A mm	B mm	L mm			
6	25	6	5-7	18	21.2	30	M3x8	1.6	47
8	40	8	5-12	24	26.8	35	M3x 10	1.6	102
10	90	10	5-15	29	32.7	45	M4x 12	3.9	185
12	90	12	5-15	29	32.7	45	M4x 12	3.9	180
14	160	14	10-17	34	39.1	50	M5x 16	7.6	272
15	160	15	10-17	34	39.1	50	M5x 16	7.6	266
16	160	16	10-17	34	39.1	50	M5x 16	7.6	261
20	300	20	10-24	42	48.2	65	M6x 16	13.2	518
25	325	25	10-26	45	50.8	75	M6x 16	13.2	623
30	400	30	20-32	53	58.1	83	M6x 18	13.2	920
35	925	35	20-40	67	74.1	95	M8x 25	32	1880
40	1100	40	30-50	77	83.4	108	M8x 25	32	2710
50	1875	50	40-52	85	93.2	124	M10x 25	63	3520

Size	Ø Bore (mm)																			
	5	6	12	14	16	18	20	22	24	28	30	32	34	36	38	40	44	46	50	52
6	24	29																		
8	24	29	57																	
10	44	53	106	124																
12	44	53	106	124																
14			172	200	229															
15			172	200	229															
16			172	200	229															
20			243	284	324	365	405	446	486											
25			243	284	324	365	405	446	486											
30							405	446	486	567	608	648								
35							742	816	890	1038	1112	1186	1261	1335	1409	1483				
40											1112	1186	1261	1335	1409	1483	1631	1706	1854	
50																2357	2593	2711	2946	3064

+ **Keyways** according to DIN 6885/1 are possible for all bore combinations.

Please contact us for our catalogues
for **SAFETY COUPLINGS** and
SHAFT HUB CONNECTIONS

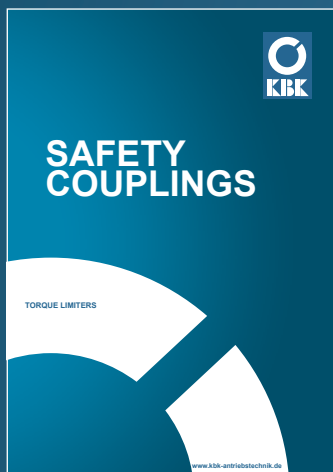

KBK Antriebstechnik GmbH

Unterlandstraße 46

63911 Klingenberg am Main

Germany

Phone: +49 9372 94061-0

Fax: +49 9372 94061-29

info@kbk-antriebstechnik.de

www.kbk-antriebstechnik.de