



# SPIELFREIE KUPPLUNGEN

METALLBALGKUPPLUNGEN  
ELASTOMERKUPPLUNGEN  
GELENKKUPPLUNGEN  
DISTANZKUPPLUNGEN  
SCHALENKUPPLUNGEN

# KBK – Das Unternehmen

Unser Unternehmen KBK Antriebstechnik GmbH wurde am 02.07.2003 gegründet. Die Idee von qualitativ hochwertigen, austauschkompatiblen Produkten zu günstigen Preisen hat uns seitdem einen ständig wachsenden Stamm zufriedener Kunden in 52 Ländern beschert. In unseren Produkten steckt eine über 30-jährige Erfahrung in Entwicklung und Produktion von Kupplungen und Spannsätzen, welche wir gepaart mit kompetenter Beratung, Service und fachlicher Kompetenz gerne für eine erfolgreiche Zusammenarbeit mit unseren Kunden einbringen. Heute steht die Marke KBK für Innovation, höchste Qualität und kürzeste Lieferzeiten. Weltweit termingerechte Lieferung ist auch durch die optimale Lage unseres Unternehmens zum Frankfurter Rhein-Main-Flughafen sowie die ideale Anbindung an das Straßennetz gewährleistet. Nutzen Sie alle unsere Stärken sowie unsere große Motivation, alle Geschäftspartner mehr als zufrieden zu stellen und sparen Sie Ihrem Unternehmen damit Zeit und Geld ein.

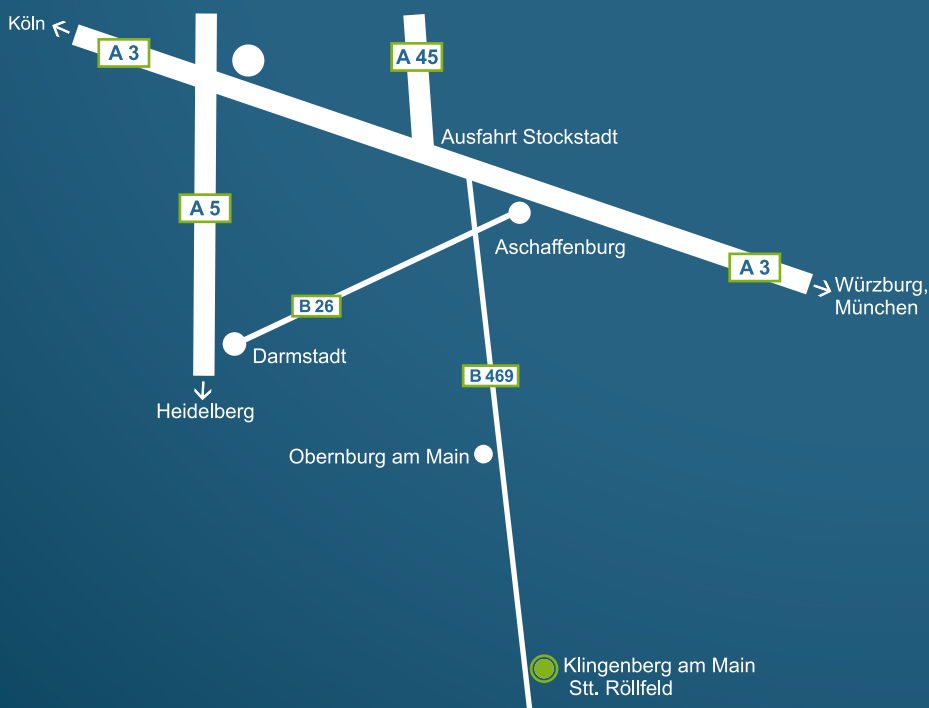

# Inhalt

## Übersicht Miniatur-Metallbalgkupplungen

KB1 - mit Stiftschraube 0,05 bis 10 Nm	Seite 5
KB1P - axial steckbar, mit Stiftschraube 0,5 bis 10 Nm	Seite 6
KB2 - mit Klemmnabe 0,1 bis 10 Nm	Seite 7
KB2H - in Halbschalenausführung 0,5 bis 10 Nm	Seite 8
KB2P - axial steckbar, mit Klemmnabe 0,5 bis 10 Nm	Seite 9
KB2VA - mit Edelstahl-Klemmnabe 0,1 bis 10 Nm	Seite 10
KB3 - mit Spreiznabe 0,5 bis 10 Nm	Seite 11
KB3P - axial steckbar, mit Spreiznabe 0,5 bis 10 Nm	Seite 12
	Seite 13

## Übersicht Metallbalgkupplungen

KB4 - mit Klemmnabe 18 bis 1400 Nm	Seite 14 / 15
KB4AL - mit Klemmnabe 80 bis 500 Nm	Seite 16
KB4C - mit Klemmnabe, Kompaktversion 18 bis 500 Nm	Seite 17
KB4F - mit Adapterflansch 18 bis 1400 Nm	Seite 18
KB4H - in Halbschalenausführung 18 bis 1400 Nm	Seite 19
KB4HC - in Halbschalenausführung 18 bis 500 Nm	Seite 20
KB4K - mit Klemmnabe 40 bis 1500 Nm	Seite 21
KB4P - axial steckbar 18 bis 500 Nm	Seite 22
KB4VA - mit Edelstahl-Klemmnabe 18 bis 500 Nm	Seite 23
KB5 - mit Innenkonus 18 bis 5000 Nm	Seite 24
KB6 - mit Außenkonus 18 bis 5000 Nm	Seite 25
KB6P - axial steckbar, mit Außenkonus 18 bis 500 Nm	Seite 26
KB7 - in Flanschausführung 18 bis 5000 Nm	Seite 27
KB8 - mit Spreiznabe 18 bis 300 Nm	Seite 28
KB8P - axial steckbar, mit Spreiznabe 18 bis 300 Nm	Seite 29
	Seite 30

# Inhalt

<b>Übersicht Elastomerkupplungen</b>	<b>Seite 31</b>
KBE1 - mit Stiftschraube Größe 5 bis 48	Seite 32
KBE2 - mit Klemmnabe Größe 5 bis 19	Seite 33
KBE2 - mit Klemmnabe Größe 24 bis 48	Seite 34
KBE2C - mit Klemmnabe, Kompaktversion Größe 7 bis 48	Seite 35
KBE2H - in Halbschalenausführung Größe 14 bis 48	Seite 36
KBE2HC - in Halbschalenausführung Größe 14 bis 48	Seite 37
KBE2D - doppelkardanisch mit Klemmnabe Größe 7 bis 38	Seite 38
KBE3 - mit Außenkonus Größe 14 bis 48	Seite 39
KBE3C - Kompaktversion mit Außenkonus Größe 14 bis 48	Seite 40
KBE4 - mit Spreiznabe Größe 14 bis 38	Seite 41
<b>Übersicht Zahnkränze zu Elastomerkupplungen</b>	<b>Seite 42</b>
<b>Übersicht Gelenk-, Distanz- und Schalenkupplungen</b>	<b>Seite 43</b>
KBGK - Linearkupplung mit Gewinde 200 bis 13000 N	Seite 44
KBGK-T - mit Klemmnabe 3 bis 58 Nm	Seite 45
DRE - Halbschalenausführung mit Elastomerstern	Seite 46
DRB - in Halbschalenausführung mit Bälgen	Seite 47
KBST - Schalenkupplung, einfach geschlitzt	Seite 48
KBST-VA - Schalenkupplung, einfach geschlitzt, Edelstahl	Seite 49
KBST-G - Schalenkupplung, geteilt	Seite 50
KBST-G-VA - Schalenkupplung, geteilt, Edelstahl	Seite 51

# Miniatürkupplungen

## KB1 | 05 ~ 100

Miniatür-Metallbalgkupplung  
mit Stiftschraube



S. 6

## KB1P | 5 ~ 100

Miniatür-Metallbalgkupplung  
axial steckbar, mit Stiftschraube



S. 7

## KB2 | 1 ~ 100

Miniatür-Metallbalgkupplung  
mit Klemmnabe



S. 8

## KB2H | 5 ~ 100

Miniatür-Metallbalgkupplung  
in Halbschalenausführung



S. 9

## KB2P | 5 ~ 100

Miniatür-Metallbalgkupplung  
axial steckbar, mit Klemmnabe



S. 10

## KB2VA | 1 ~ 100

Miniatür-Metallbalgkupplung  
mit Edelstahl-Klemmnabe



S. 11

## KB3 | 5 ~ 100

Miniatür-Metallbalgkupplung  
mit Spreiznabe



S. 12

## KB3P | 5 ~ 100

Miniatür-Metallbalgkupplung  
axial steckbar, mit Spreiznabe



S. 13

### Miniatur-Metallbalgkupplung

mit Stiftschraube

optional  
lasergeschweißt  
optional komplett  
in Edelstahl

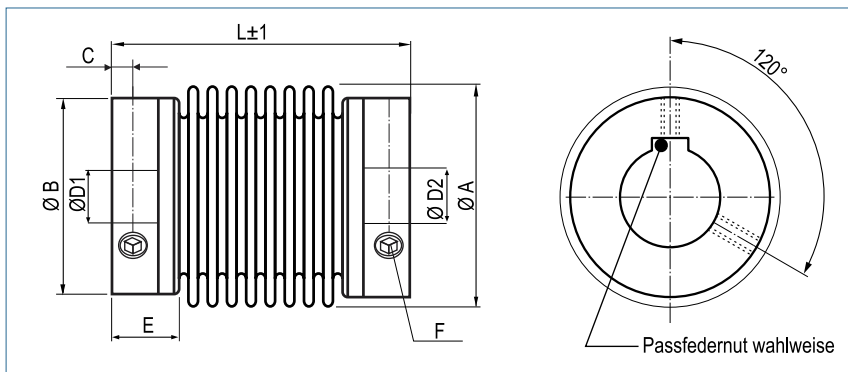

**Bestellbeispiel**

**KB1 / 45 - 40 - 10 - 18 - (S)**

Typ / Größe      Länge L      ØD1 (H7)      ØD2 (H7)      Optionen

Größe	Drehmoment TKN (Nm)	Abmessungen (mm)							Technische Daten							
		L Länge	Ø A Außen-durch-messer	D1/D2 Bohrungen (H7) von-bis	Ø B Naben durch-messer	C	E Naben-länge	F Schraube (ISO4029) TA (Nm)	Masse (g)	Massen-trägheits-moment J (g cm <sup>2</sup> )	Federsteifigkeit			Versatz		
										Torsion CT (Nm/rad)	radial CR (N/mm)	axial CA (N/mm)	radial ΔKr (mm)	axial ΔKa (mm)	Winkel ΔKw (°)	
05	0.05	14	6.5	1-3	6.5	1.5	4	1x M2 0.35	1	0.1	50	6	9	0.1	0.4	1
1	0.1	23	10	1-4	10	2	6	1x M3 0.5	3	0.45	65	10	14	0.12	0.2	1.2
5	0.5	19	15	3-8	13.5	2	6	1x M3 0.5	4	1.3	260	43	13	0.1	0.2	1
		4.5							1.5	200	18	10	0.15	0.3	1.5	
		5							1.6	160	9	8	0.2	0.4	2	
10	1	21	15	3-8	13.5	2	6	1x M3 0.5	5.5	1.8	510	74	27	0.1	0.2	1
		6							2	380	31	20	0.15	0.3	1.5	
		7							2.3	310	16	16	0.2	0.4	2	
15	1.5	26	19	3-12	19	3	8	2x M4	10	6	750	59	15	0.1	0.3	1.5
		30		8#				1.5	12	7.4	700	20	9	0.15	0.4	2
20	2	22	24	3-14	21.5	3	6	2x M4	11	9.2	1500	67	12	0.15	0.3	1.5
		28		10#				13	12.6	1300	21	11	0.2	0.4	1.5	
		32		1.5				15	13.5	1050	11	9	0.25	0.5	2	
45	4.5	40	32	6-19	29	4	12	2x M6	44	68	6500	168	32	0.1	0.3	1.5
		48		13#				3	50	79	4200	41	20	0.2	0.5	2
100	10	45	40	6-24	36	4	12	2x M6	60	150	8100	120	27	0.15	0.4	1.5
		55		17#				3	79	210	6800	29	17	0.3	0.6	2

<b>Drehzahl</b>	max. 15000 min <sup>-1</sup>
<b>Material</b>	Balg - Edelstahl, Größe 05: Bronze Nabe - Aluminium
<b>Nabe</b>	Bohrungstoleranz: H7
<b>Temperaturbereich</b>	-30 °C ~ 120 °C
<b>Passfedernut</b>	wahlweise nach DIN 6885 größtmögliche Bohrung mit # gekennzeichnet

## Miniatur-Metallbalgkupplung

axial steckbar, mit Stiftschraube

optional  
lasergeschweißt  
optional komplett  
in Edelstahl

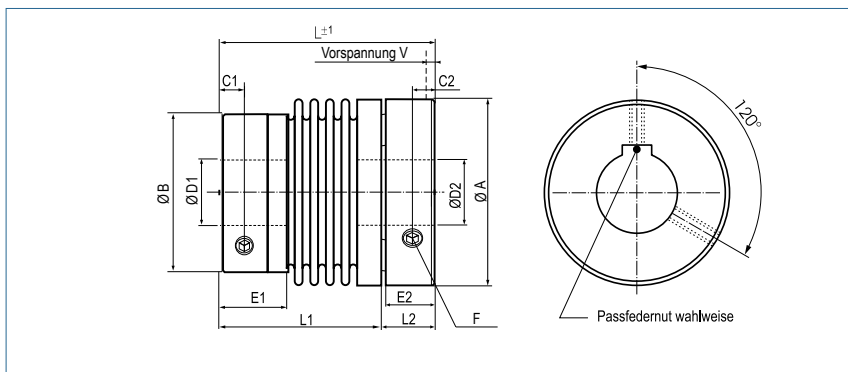

### Bestellbeispiel

**KB1P / 15 - 32 - 5 - 10 - D - (S)**

Typ / Größe                      Länge L                      ØD1 (H7)                      ØD2 (H7)                      Steckung                      Optionen

Größe	Drehmoment TKN (Nm)	Abmessungen (mm)								Technische Daten							
		Länge	Ø A	Ø B	D1	D2	C1	C2	F	Masse (g)	Massenträgheitsmoment J (g cm <sup>2</sup> )	Federsteifigkeit			Versatz		
			Stecknaben durchmesser	Stiftschrauben durchmesser	Bohrung (H7) von-bis	Bohrung (H7) von-bis			Schraube (ISO4029) TA (Nm)			Torsion CT (Nm/rad)	radial CR (N/mm)	axial CA (N/mm)	radial Δ Kr (mm)	axial Δ Ka (mm)	Winkel Δ Kw (°)
5	0.5	22	15.5	13.5	3-8	3-8	2	2	1xM3	5.9	1.9	260	43	13	0.1	0.2	1
		26								6.6	2.2	200	18	10	0.15	0.3	1.5
		30								7.4	2.4	160	9	8	0.2	0.4	2
10	1	24	15.5	13.5	3-8	3-8	2	2	1xM3	8.1	2.7	510	74	27	0.1	0.2	1
		28								8.8	2.9	380	31	20	0.15	0.3	1.5
		32								10.3	3.4	310	16	16	0.2	0.4	2
15	1.5	28	20	19	3-12	3-10	3	2.5	2xM4	14.7	8.8	750	59	15	0.1	0.3	1.5
		32			8#	7#				1.5	17.6	10.9	700	20	9	0.15	0.4
20	2	27	25	21.5	3-14	3-14	3	2.5	2xM4	16.2	13.5	1500	67	12	0.15	0.3	1.5
		37			10#	10#				1.5	22	19.9	1050	11	9	0.25	0.5
45	4.5	44	32.5	29	6-19	6-16	4	4	2xM6	64.7	100	6500	168	32	0.1	0.3	1.5
		52			13#	11#				3	73.5	116	4200	41	20	0.2	0.5
100	10	50	40.5	36	6-24	6-25	4	4	2xM6	88.2	220.5	8100	120	27	0.15	0.4	1.5
		60			17#	18#				3	116.1	308.7	6800	29	17	0.3	0.6

<b>Drehzahl</b>	max. 15000 min <sup>-1</sup>
<b>Material</b>	Balg - Edelstahl Nabe - Aluminium
<b>Nabe</b>	Bohrungstoleranz: H7
<b>Temperaturbereich</b>	-30 °C ~ 120 °C
<b>Passfedernut</b>	wahlweise nach DIN 6885 größtmögliche Bohrung mit # gekennzeichnet

Größe	Abmessungen (mm)					
	E1	E2	L1	L2	L3	V
5	6	4	17	5	9	0.5
			21			
			25			
10	6	4	19	5	9	0.5
			23			
			27			
15	8	5	22	6	11	0.5
			26			
20	6	5	21	6	11	0.5
			27			
			31			
45	12	8	35	9	16	0.5
			43			
100	12	8	41	9	17	1
			45			
			51			

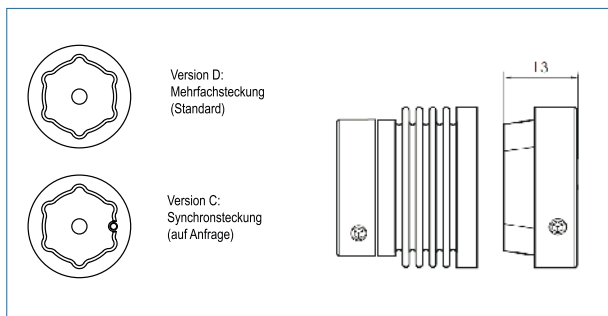

# Miniatur-Metallbalgkupplung

mit Klemmnabe

optional  
lasergeschweißt  
optional komplett  
in Edelstahl

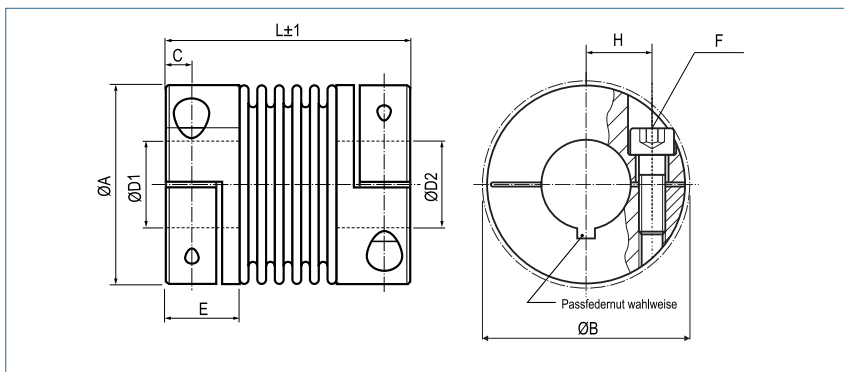

## Bestellbeispiel

**KB2 / 45 - 50 - 10 - 16 - (S)**

Typ / Größe      Länge L      ØD1 (H7)      ØD2 (H7)      Optionen

Größe	Drehmoment TKN (Nm)	Abmessungen (mm)								Technische Daten							
		L Länge	Ø A Außen- durch- messer	D1/D2 Bohrun- gen (H7) von-bis	H	C	Ø B Stör Ø	E Naben- länge	F Schraube (ISO4762) TA (Nm)	Masse (g)	Massen- trägheits- moment J (g cm <sup>2</sup> )	Federsteifigkeit			Versatz		
											Torsion CT (Nm/rad)	radial CR (N/mm)	axial CA (N/mm)	radial ΔKr (mm)	axial ΔKa (mm)	Winkel ΔKw (°)	
1	0.1	25	10	1-4	3.4	2	11	7	M1.6 0.1	3	0.5	65	10	14	0.12	0.2	1.2
		21		3-8					M2	7.5	2.7	260	43	13	0.1	0.2	1
5	0.5	25	15.5	8#	5.2	2.5	17.5	7	0.43	7.8	2.8	200	18	10	0.15	0.3	1.5
		28								8.2	3	160	9	8	0.2	0.4	2
		23		3-8					M2	9	3.1	510	74	27	0.1	0.2	1
10	1	26	15.5	8#	5.2	2.5	17.5	7	0.43	9.3	3.4	380	31	20	0.15	0.3	1.5
		31								10	3.7	310	16	16	0.2	0.4	2
15	1.5	26	20	3-10	7	3	21	8,5	M2.5	13	8	750	59	15	0.1	0.3	1.5
		31		10#					0.85	15	9.3	700	20	9	0.15	0.4	2
20	2	32		3-14					M3	29	24	1500	67	12	0.15	0.3	1.5
		38	25	14#	9	3.5	27	11		32	27	1300	21	11	0.2	0.4	1.5
		42							2	33	29	1050	11	9	0.25	0.5	2
45	4.5	41	32.5	6-18	12	5	34	13	M4	61	100	6500	168	32	0.1	0.3	1.5
		50		18#					3.5	67	112	4200	41	20	0.2	0.5	2
100	10	47		6-25					M4	86	233	8100	120	27	0.15	0.4	1.5
		57	40.5	25#	15.5	5	41.5	13,5	4.5	106	290	6800	29	17	0.3	0.6	2

<b>Drehzahl</b>	max. 15000 min <sup>-1</sup>
<b>Material</b>	Balg - Edelstahl Nabe - Aluminium
<b>Nabe</b>	Bohrungstoleranz: H7
<b>Temperaturbereich</b>	-30 °C ~ 120 °C
<b>Passfedernut</b>	wahlweise nach DIN 6885 größtmögliche Bohrung mit # gekennzeichnet



## Miniatur-Metallbalgkupplung

in Halbschalenausführung

optional  
lasergeschweißt  
optional komplett  
in Edelstahl

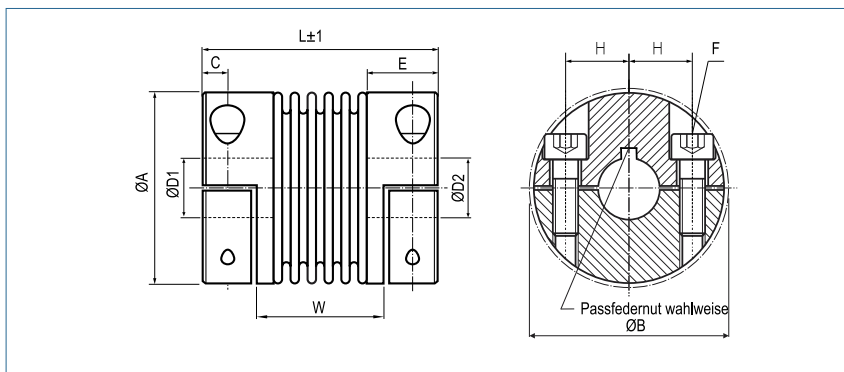

### Bestellbeispiel

**KB2H / 45 - 50 - 10 - 16 - (S)**

Typ / Größe

Länge  
L

ØD1  
(H7)

ØD2  
(H7)

Optionen

Größe	Drehmoment TKN (Nm)	Abmessungen (mm)									Technische Daten							
		L Länge	Ø A Außen- durch- messer	D1/D2 Bohrun- gen (H7) von~bis	H	C	ØB Stör Ø	E Naben- länge	W	F Schraube (ISO4762) TA (Nm)	Masse (g)	Massen- trägheits- moment J (g cm <sup>2</sup> )	Federsteifigkeit			Versatz		
												Torsion CT (Nm/rad)	radial CR (N/mm)	axial CA (N/mm)	radial ΔKr (mm)	axial ΔKa (mm)	Winkel ΔKw (°)	
5	0.5	21	15.5	3-8	5.2	2.5	17.5	7	12	M2	7.5	2.7	260	43	13	0.1	0.2	1
		16							0.43	7.8	2.8	200	18	10	0.15	0.3	1.5	
		19								8.2	3	160	9	8	0.2	0.4	2	
10	1	23	15.5	3-8	5.2	2.5	17.5	7	14	M2	9	3.1	510	74	27	0.1	0.2	1
		17							0.43	9.3	3.4	380	31	20	0.15	0.3	1.5	
		22		10						3.7	310	16	16	0.2	0.4	2		
15	1.5	26	20	3-10	7	3	21	8.5	14.4	M2.5	13	8	750	59	15	0.1	0.3	1.5
		19.4		0.85					15	9.3	700	20	9	0.15	0.4	2		
20	2	32	25	3-14	9	3.5	27	11	18.4	M3	29	24	1500	67	12	0.15	0.3	1.5
		24.4							2	32	27	1300	21	11	0.2	0.4	1.5	
		28.4		33						29	1050	11	9	0.25	0.5	2		
45	4.5	41	32.5	6-18	12	5	34	13	24	M4	61	100	6500	168	32	0.1	0.3	1.5
		33		3.5					67	112	4200	41	20	0.2	0.5	2		
100	10	47	40.5	6-25	15.5	5	41.5	13.5	29	M4	86	233	8100	120	27	0.15	0.4	1.5
		39		4.5					106	290	6800	29	17	0.3	0.6	2		

<b>Drehzahl</b>	max. 15000 min <sup>-1</sup>
<b>Material</b>	Balg - Edelstahl Nabe - Aluminium
<b>Nabe</b>	Bohrungstoleranz: H7
<b>Temperaturbereich</b>	-30 °C ~ 120 °C
<b>Passfedernut</b>	wahlweise nach DIN 6885 größtmögliche Bohrung mit # gekennzeichnet

## Miniatur-Metallbalgkupplung

axial steckbar, mit Klemmnabe

optional  
lasergeschweißt  
optional komplett  
in Edelstahl

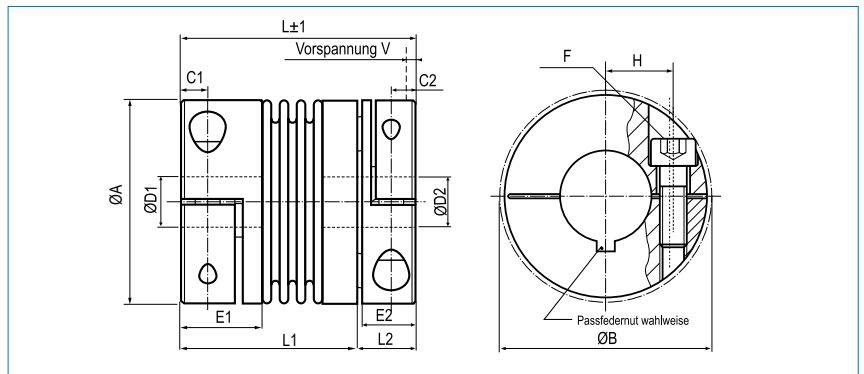

### Bestellbeispiel

**KB2P / 15 - 30 - 5 - 10 - D - (S)**

Typ / Größe      Länge L      ØD1 (H7)      ØD2 (H7)      Steckung      Optionen

Größe	Drehmoment TKN (Nm)	Abmessungen (mm)								Technische Daten								
		L Länge	Ø A Außen- durch- messer	Ø B Stör Ø	D1 Bohrung (H7) von-bis	D2 Bohrung (H7) von-bis	H	C1	C2	F Schraube (ISO4762) TA (Nm)	Masse (g)	Massen- trägheits- moment J (g cm <sup>2</sup> )	Federsteifigkeit			Versatz		
												Torsion CT (Nm/rad)	radial CR (N/mm)	axial CA (N/mm)	radial Δ Kr (mm)	axial Δ Ka (mm)	Winkel Δ Kw (°)	
5	0.5	25	15.5	17.5	3-8	3-8	5.2	2.5	2.5	M2	8.7	3.1	260	43	13	0.1	0.2	1
		29			8#					9.1	3.3	200	18	10	0.15	0.3	1.5	
		32			0.43					9.6	3.5	160	9	8	0.2	0.4	2	
10	1	27	15.5	17.5	3-8	3-8	5.2	2.5	2.5	M2	10.5	3.6	510	74	27	0.1	0.2	1
		30			8#					10.8	3.9	380	31	20	0.15	0.3	1.5	
		32			0.43					11.7	4.3	310	16	16	0.2	0.4	2	
15	1.5	30	20	21	3-10	3-10	7	3	3	M2.5	15.2	9.3	750	59	15	0.1	0.3	1.5
		35			10#	7#				0.85	17.5	10.8	700	20	9	0.15	0.4	2
20	2	37	25	27	3-14	3-14	9	3.5	3.5	M3	33.8	27.8	1500	67	12	0.15	0.3	1.5
		43			14#	10#				2	38.5	33.6	1050	11	9	0.25	0.5	2
		47																
45	4.5	49	32.5	34	6-18	6-16	12	5	5	M4	71	116	6500	168	32	0.1	0.3	1.5
		58			18#	11#				3.5	78	129.9	4200	41	20	0.2	0.5	2
100	10	56	40.5	41.5	6-25	6-25	15.5	5	5	M4	100	270.3	8100	120	27	0.15	0.4	1.5
		66			25#	18#				4.5	123.5	336.4	6800	29	17	0.3	0.6	2

<b>Drehzahl</b>	max. 15000 min <sup>-1</sup>
<b>Material</b>	Balg - Edelstahl Nabe - Aluminium
<b>Nabe</b>	Bohrungstoleranz: H7
<b>Temperaturbereich</b>	-30 °C ~ 120 °C
<b>Passfedernut</b>	wahlweise nach DIN 6885 größtmögliche Bohrung mit # gekennzeichnet

Größe	Abmessungen (mm)					
	E1	E2	L1	L2	L3	V
5	7	6	18	7	11	0.5
			22			
			25			
10	7	6	20	7	11	0.5
			23			
			25			
15	8.5	6.5	22.5	7.5	12.5	0.5
			27.5			
20	11	10	26	11	16	0.5
			32			
			36			
45	13	12	36	14	20	0.5
			45			
100	13.5	12	43	14	21	1
			53			

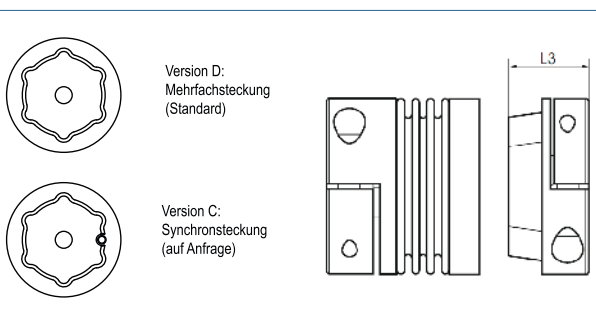

### Miniatur-Metallbalgkupplung

mit Edelstahl-Klemmnabe

optional  
lasergeschweißt

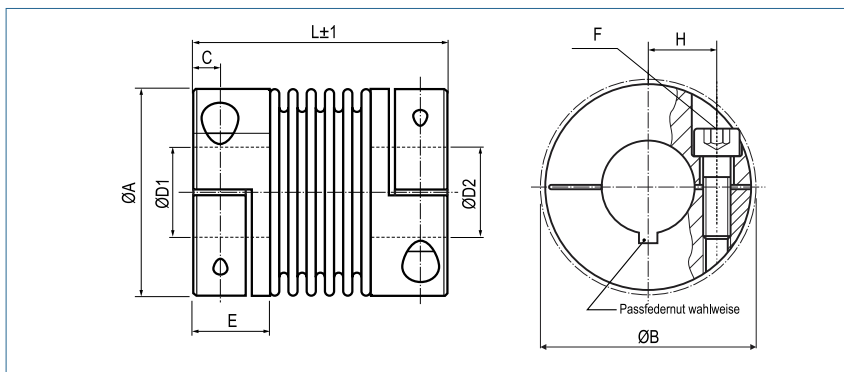

**Bestellbeispiel**

**KB2 / 45 - 50 - 10 - 16 - VA/VAW**

Typ / Größe      Länge L      ØD1 (H7)      ØD2 (H7)      Edelstahl / Edelstahl geklebt / lasergeschweißt

Größe	Drehmoment TKN (Nm)	Abmessungen (mm)								Technische Daten							
		L Länge	Ø A Außen-durch-messer	D1/D2 Bohrungen (H7) von-bis	H	C	Ø B Stör Ø	E Naben-länge	F Schraube (ISO4762) TA (Nm)	Masse (g)	Massen-trägheits-moment J (g cm <sup>2</sup> )	Federsteifigkeit			Versatz		
											Torsion CT (Nm/rad)	radial CR (N/mm)	axial CA (N/mm)	radial ΔKr (mm)	axial ΔKa (mm)	Winkel ΔKw (°)	
1	0.1	25	10	1-4	3.4	2	11	7	M1.6 0.1	7	1	65	10	14	0.12	0.2	1.2
		21	15.5	3-8	5.2	2.5	17.5	7	M2	18	5.9	260	43	13	0.1	0.2	1
25	8#	18		6.2					200	18	10	0.15	0.3	1.5			
28	0.43	19		6.6					160	9	8	0.2	0.4	2			
10	1	23	15.5	3-8	5.2	2.5	17.5	7	M2	19	6.8	510	74	27	0.1	0.2	1
		26		8#					20	7.5	380	31	20	0.15	0.3	1.5	
		31		0.43					21	8.1	310	16	16	0.2	0.4	2	
15	1.5	26	20	3-10	7	3	21	8,5	M2.5	36	18	750	59	15	0.1	0.3	1.5
		31		10#					0.85	38	21	700	20	9	0.15	0.4	2
20	2	32	25	3-14	9	3.5	27	11	M3	70	53	1500	67	12	0.15	0.3	1.5
		38		14#					73	60	1300	21	11	0.2	0.4	1.5	
		42		2					75	64	1050	11	9	0.25	0.5	2	
45	4.5	41	32.5	6-18	11.5	5	34	13	M4	133	220	6500	168	32	0.1	0.3	1.5
		50		18#					139	246	4200	41	20	0.2	0.5	2	
100	10	47	40.5	6-25	15.5	5	41.5	13,5	M4	244	513	8100	120	27	0.15	0.4	1.5
		57		25#					13,5	4.5	261	638	6800	29	17	0.3	0.6

<b>Drehzahl</b>	max. 15000 min <sup>-1</sup>
<b>Material</b>	Balg - hochelastischem Edelstahl Nabe - Edelstahl
<b>Nabe</b>	Bohrungstoleranz: H7
<b>Temperaturbereich</b>	VA -30 °C ~ 120 °C (geklebt) VAW -30 °C ~ 250 °C (lasergeschweißt)
<b>Passfedernut</b>	wahlweise nach DIN 6885 größtmögliche Bohrung mit # gekennzeichnet

## Miniatur-Metallbalgkupplung

mit Spreiznabe

optional  
lasergeschweißt  
optional komplett  
in Edelstahl

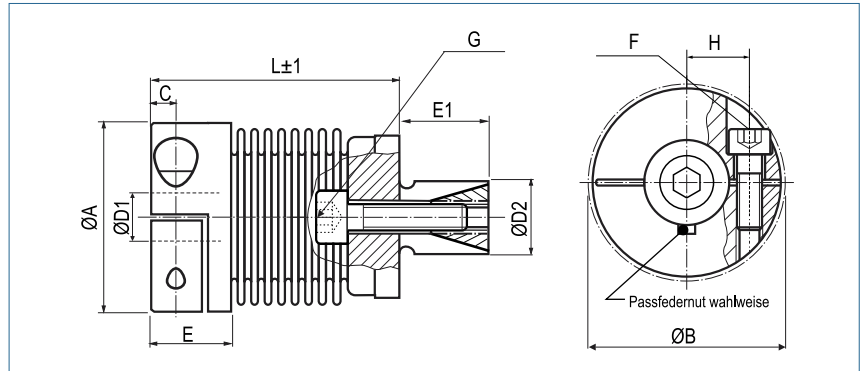

### Bestellbeispiel

**KB3 / 45 - 36 - 10 - 18 - (S)**

Typ / Größe      Länge L      ØD1 (H7)      ØD2 (f7)      Optionen

Größe	Drehmoment TKN (Nm)	Abmessungen (mm)										Technische Daten							
		L Länge	Ø A Außen-durch-messer	D1 Bohrung (H7) von-bis	D2 Spreiz-dorn (f7) von-bis	Ø B Stör Ø	H	C	E	E1	F/G Schraube (ISO4762) TA (Nm)	Masse (g)	Massen-trägheits-moment J (g cm²)	Federsteifigkeit			Versatz		
													Torsion CT (Nm/rad)	radial CR (N/mm)	axial CA (N/mm)	radial ΔKr (mm)	axial ΔKa (mm)	Winkel ΔKw (°)	
5	0.5	20	15.5	3-8	8-12	17,5	5.2	2.5	7	8	M2/M3	12.8	2.9	260	43	13	0.1	0.2	1
		24		8#							0.3/1	13.2	3.1	200	18	10	0.15	0.3	1.5
		27		8#							0.3/1	13.5	3.2	160	9	8	0.2	0.4	2
10	1	22	15,5	3-8	8-12	17,5	5.2	2.5	7	8	M2/M3	14.1	3.3	510	74	27	0.1	0.2	1
		26		8#							0.3/1	14.6	3.4	380	31	20	0.15	0.3	1.5
		30		8#							0.3/1	15.3	3.6	310	16	16	0.2	0.4	2
15	1.5	25	20	3-10	10-14	21	7	3	8,5	12	M2.5/M4	27.2	11	750	59	15	0.1	0.3	1.5
		29		10#							0.8/3	29.3	12	700	20	9	0.15	0.4	2
20	2	28	25	3-14	10-16	27	9	3.5	11	12	M3/M4	40.1	25	1500	67	12	0.15	0.3	1.5
		34		14#							1/3	43.2	29	1300	21	11	0.2	0.4	1.5
		38		14#							1/3	49.1	30	1050	11	9	0.25	0.5	2
45	4.5	36	32.5	6-18	14-20	34	12	5	13	16	M4/M5	86.5	98	6500	168	32	0.1	0.3	1.5
		44		18#							3/5.9	92.9	110	4200	41	20	0.2	0.5	2
100	10	41	40.5	6-25	16-22	41,5	15.5	5	13,5	20	M4/M6	135	235	8100	120	27	0.15	0.4	1.5
		51		25#							3/10	154	292	6800	29	17	0.3	0.6	2

<b>Drehzahl</b>	max. 15000 min <sup>-1</sup>
<b>Material</b>	Balg - Edelstahl Klemmnabe - Aluminium Spreiznabe - Stahl
<b>Nabe</b>	Bohrungstoleranz: H7
<b>Temperaturbereich</b>	-30 °C ~ 120 °C
<b>Passfedernut</b>	wahlweise nach DIN 6885 größtmögliche Bohrung mit # gekennzeichnet

## Miniatur-Metallbalgkupplung

axial steckbar, mit Spreiznabe

optional  
lasergeschweißt  
optional komplett  
in Edelstahl

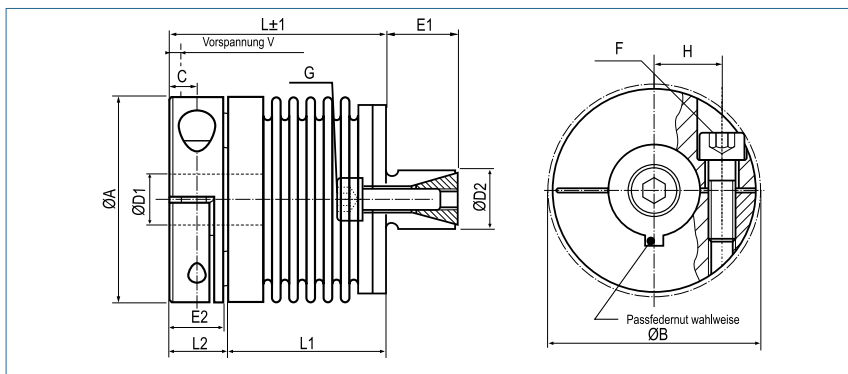

### Bestellbeispiel

**KB3P / 15 - 29 - 5 - 10 - D - (S)**

Typ / Größe

Länge  
L

ØD1  
(H7)

ØD2  
(f7)

Steckung

Optionen

Größe	Drehmoment TKN (Nm)	Abmessungen (mm)								Technische Daten							
		L Länge	Ø A Außen- durch- messer	Ø B Stör Ø	D1 Bohrung (H7) von-bis	D2 Spreiz- dorn (f7) von-bis	H	C	F/G Schraube (ISO4762) TA (Nm)	Masse (g)	Massen- trägheits- moment J (g cm <sup>2</sup> )	Federsteifigkeit			Versatz		
											Torsion CT (Nm/rad)	radial CR (N/mm)	axial CA (N/mm)	radial Δ Kr (mm)	axial Δ Ka (mm)	Winkel Δ Kw (°)	
5	0.5	24	15.5	17.5	3-8	8-12	5.2	2.5	M2/M3	14.9	3.4	260	43	13	0.1	0.2	1
		28			8#				15.4	3.6	200	18	10	0.15	0.3	1.5	
		31			0.43/1				15.8	3.7	160	9	8	0.2	0.4	2	
10	1	26	15.5	17.5	3-8	8-12	5.2	2.5	M2/M3	16.4	3.8	510	74	27	0.1	0.2	1
		30			8#				17	4	380	31	20	0.15	0.3	1.5	
		34			0.43/1				17.8	4.2	310	16	16	0.2	0.4	2	
15	1.5	29	20	21	3-10	10-14	7	3	M2.5/M4	31.7	12.8	750	59	15	0.1	0.3	1.5
		33			10#				34.1	14	700	20	9	0.15	0.4	2	
20	2	33	25	27	3-14	10-16	9	3.5	M3/M4	46.7	29.1	1500	67	12	0.15	0.3	1.5
		39			14#				50.3	33.8	1300	21	11	0.2	0.4	1.5	
		43			2/3				57.2	34.9	1050	11	9	0.25	0.5	2	
45	4.5	43	32.5	34	6-18	14-20	12	5	M4/M5	100.7	114.1	6500	168	32	0.1	0.3	1.5
		51			18#				108.1	128	4200	41	20	0.2	0.5	2	
100	10	49	40.5	41.5	6-25	16-22	15.5	5	M4/M6	157.1	273.5	8100	120	27	0.15	0.4	1.5
		59			25#				179.3	339.9	6800	29	17	0.3	0.6	2	



<b>Drehzahl</b>	max. 15000 min <sup>-1</sup>
<b>Material</b>	Balg - Edelstahl Klemmnabe - Aluminium Spreiznabe - Stahl
<b>Nabe</b>	Bohrungstoleranz: H7
<b>Temperaturbereich</b>	-30 °C ~ 120 °C
<b>Passfedernut</b>	wahlweise nach DIN 6885 größtmögliche Bohrung mit # gekennzeichnet

Größe	Abmessungen (mm)					
	E1	E2	L1	L2	L3	V
5	8	6	17	7	11	0.5
			21			
			24			
10	8	6	19	7	11	0.5
			23			
			27			
15	12	6.5	21.5	7.5	12.5	0.5
			25.5			
20	12	10	22	11	16	0.5
			28			
			32			
45	16	12	30	13	20	0.5
			38			
100	20	12	36	13	21	1
			46			

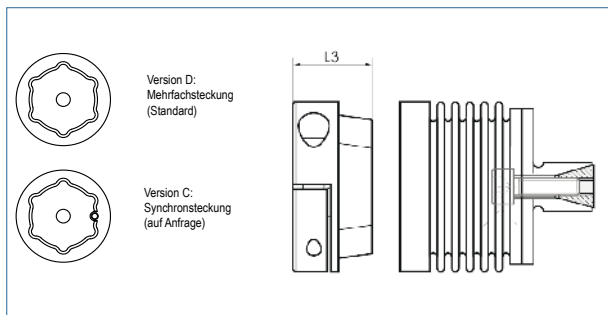

# Metallbalgkupplungen

## KB4 | 18 ~ 1400

Metallbalgkupplung  
mit Klemmnabe



S. 16

## KB4AL | 80 ~ 500

Metallbalgkupplung  
mit Klemmnabe



S. 17

## KB4C | 18 ~ 500

Metallbalgkupplung  
kompakt mit Klemmnabe



S. 18

## KB4F | 18 ~ 1400

Metallbalgkupplung  
mit Adapterflansch



S. 19

## KB4H | 18 ~ 1400

Metallbalgkupplung  
in Halbschalenausführung



S. 20

## KB4HC | 18 ~ 500

Metallbalgkupplung  
in Halbschalenausführung



S. 21

## KB4K | 40 ~ 1500

Metallbalgkupplung  
mit Klemmnabe



S. 22

## KB4P | 18 ~ 500

Metallbalgkupplung  
axial steckbar



S. 23

## KB4VA | 18 ~ 500

Metallbalgkupplung  
mit Edelstahl-Klemmnabe



S. 24

## KB5 | 18 ~ 5000

Metallbalgkupplung  
mit Innenkonus



S. 25

## KB6 | 18 ~ 5000

Metallbalgkupplung  
mit Außenkonus



S. 26

## KB6P | 18 ~ 500

Metallbalgkupplung  
Flanschausführung



S. 27

# Metallbalgkupplungen

## KB7 | 18 ~ 5000

Metallbalgkupplung  
Flanschausführung



S. 28

## KB8 | 18 ~ 300

Metallbalgkupplung  
mit Spreiznabe



S. 29

## KB8P | 18 ~ 300

Metallbalgkupplung  
axial steckbar, mit Spreiznabe



S. 30

# Metallbalgkupplung

mit Klemmnabe

optional  
lasergeschweißt  
optional komplett  
in Edelstahl

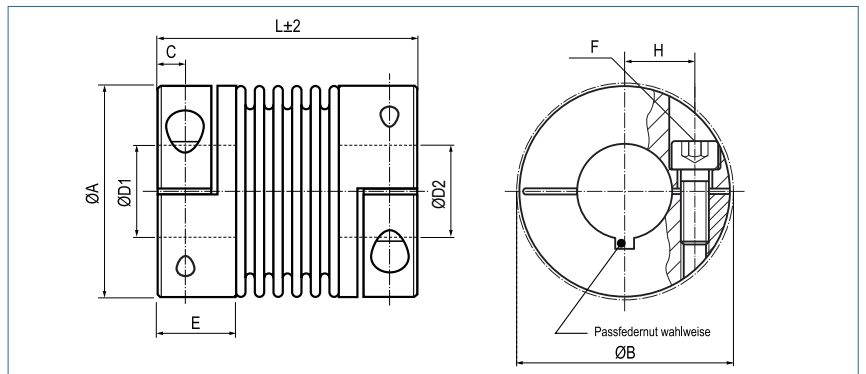

## Bestellbeispiel

**KB4 / 60 - 89 - 12 - 32 - (S)**

Typ / Größe      Länge L      ØD1 (H7)      ØD2 (H7)      Optionen

Größe	Drehmoment TKN (Nm)	Abmessungen (mm)								Technische Daten								
		L Länge	Ø A Außen- durch- messer	D1/D2 Bohrungen (H7) von-bis	H	C	E	B Stör Ø	F Schraube (ISO4762) TA (Nm)	Masse (kg)	Massen- trägheits- moment J (g m²)	Federsteifigkeit			Versatz			max Drehzahl min-1
											Torsion CT 10³ (Nm/rad)	radial CR (N/mm)	axial CA (N/mm)	radial ΔKr (mm)	axial ΔKa (mm)	Winkel ΔKw (°)		
18	18	63	45	10-25.4	17	5.5	19.5	47.4	M5	0.1	0.04	20	205	50	0.2	0.5	1.5	12800
		71							8	0.15	0.05	15	82	36	0.25	0.5	2	12800
30	30	65	56	10-32	20	7.5	24.5	56.4	M6	0.3	0.15	38	720	50	0.15	0.6	1.5	10300
		73		15					0.32	0.16	28	225	28	0.25	1	2	10300	
60	60	79	66	12-35	23	10	29	66	M8	0.5	0.33	75	1150	90	0.15	0.6	1.5	8700
		89							40	0.6	0.36	50	340	50	0.25	1	2	8700
80	80	91	82	14-44	28	11	33.5	82.9	M10	2.3	2.3	128	1200	80	0.2	0.5	1.5	6900
		102							84	2.4	2.4	75	400	50	0.25	0.8	2	6900
150	150	91	82	19-44	28	11	33.5	82.9	M10	2.3	2.5	155	2020	145	0.2	0.5	1.5	6900
		102							84	2.4	2.6	105	595	85	0.25	0.8	2	6900
200	200	101	90	22-47	31	13	38	90.8	M12	2.6	3.3	175	2500	145	0.2	0.5	1.5	6400
		113							125	2.7	3.5	120	460	82	0.25	0.8	2	6400
300	300	105	110	30-60	40	13	38	110	M12	4.3	7.6	502	6300	280	0.2	0.5	1.5	6000
		116							145	4.4	7.8	285	1400	145	0.25	0.8	2	6000
500	500	112	122	35-70	42	15	42	122	M12	5.5	13.5	690	7790	100	0.2	0.5	1.5	5000
		123							145	5.6	13.7	320	970	85	0.25	1	2	5000
800	800	168	157	40-80	55	22.5	55	170.3	2xM20 400	14.3	56.9	1270	700	275	0.2	0.8	1.8	5000
1400	1400	168	157	50-80	55	22.5	55	170.3	2xM20 470	14.8	57.7	1270	700	275	0.2	0.8	1.8	5000

<b>Material</b>	Balg - Edelstahl Nabe - Größe 18 - 60: Aluminium Nabe - ab Größe 80: Stahl
<b>Nabe</b>	Bohrungstoleranz: H7
<b>Temperaturbereich</b>	-30 °C ~ 120 °C Größe 800/1400: -30 °C ~ 250 °C
<b>Passfedernut</b>	wahlweise nach DIN 6885 größtmögliche Bohrung mit # gekennzeichnet



**Metallbalgkupplung in Aluminiumausführung**

mit Klemmnabe

optional  
lasergeschweißt  
optional komplett  
in Edelstahl

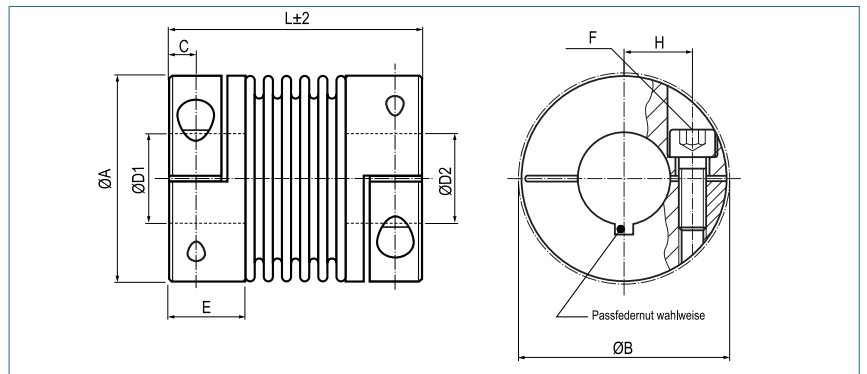

**Bestellbeispiel**

**KB4AL / 80 - 91 - 15 - 20 - (S)**

Typ / Größe      Länge L      ØD1 (H7)      ØD2 (H7)      Optionen

Größe	Drehmoment TKN (Nm)	Abmessungen (mm)								Technische Daten								
		L Länge	Ø A Außen- durch- messer	D1/D2 Bohrungen (H7) von-bis	H	C	E	Stör Ø	F Schraube (ISO4762) TA (Nm)	Masse (kg)	Massen- trägheits- moment J (g m <sup>2</sup> )	Federsteifigkeit			Versatz			max Dreh- zahl min-1
80	80	91	82	12-44	28	11	33.5	82.9	M10	0.8	0.90	128	1200	80	0.2	0.5	1.5	6900
		84							0.85	0.95	75	400	50	0.25	0.8	2	6900	
150	150	91	82	14-44	28	11	33.5	82.9	M10	0.9	1.0	155	2020	145	0.2	0.5	1.5	6900
		84							0.95	1.05	105	595	85	0.25	0.8	2	6900	
200	200	101	90	16-47	31	13	38	90.8	M12	1.17	1.49	175	2500	145	0.2	0.5	1.5	6400
		125							1.21	1.57	120	460	82	0.25	0.8	2	6400	
300	300	105	110	20-60	40	13	38	110	M12	1.62	3.28	502	6300	280	0.2	0.5	1.5	6000
		145							1.66	3.37	285	1400	145	0.25	0.8	2	6000	
500	500	112	122	25-70	42	15	42	122	M12	2.4	6.4	690	7790	100	0.2	0.5	1.5	5000
		145							2.5	6.7	320	970	85	0.25	1.0	2	5000	

<b>Material</b>	Balg - Edelstahl Nabe - Aluminium
<b>Nabe</b>	Bohrungstoleranz: H7
<b>Temperaturbereich</b>	-30 °C ~ 120 °C
<b>Passfedernut</b>	wahlweise nach DIN 6885

# Metallbalgkupplung kompakt

mit Klemmnabe

optional  
lasergeschweißt  
optional komplett  
in Edelstahl

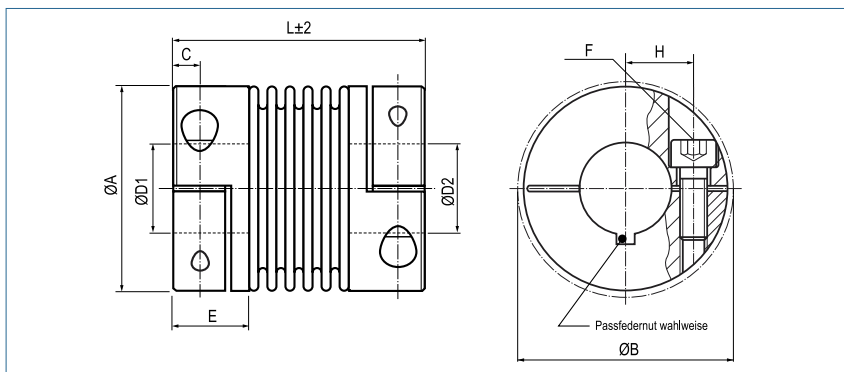

## Bestellbeispiel

**KB4C / 60 - 67 - 12 - 32 - (S)**

Typ / Größe

Länge  
L

ØD1  
(H7)

ØD2  
(H7)

Optionen

Größe	Drehmoment TKN (Nm)	Abmessungen (mm)								Technische Daten								
		L Länge	Ø A Außen-durch-messer	D1/D2 Bohrungen (H7) von-bis	H	C	E	B Stör Ø	F Schraube (ISO4762) TA (Nm)	Masse (kg)	Massen-trägheits-moment J (g m²)	Federsteifigkeit			Versatz			max Drehzahl min-1
											Torsion CT 10³ (Nm/rad)	radial CR (N/mm)	axial CA (N/mm)	radial ΔKr (mm)	axial ΔKa (mm)	Winkel ΔKw (°)		
18	18	58	45	10-25.4	17	5.5	17.5	47.4	M5	0.07	0.03	20	205	50	0.2	0.5	1.5	12800
		8							0.12	0.04	15	82	36	0.25	0.5	2	12800	
30	30	58	56	10-32	20	7.3	21	56.4	M6	0.26	0.13	38	720	50	0.15	0.6	1.5	10300
		15		0.27					0.14	28	225	28	0.25	1	2	10300		
60	60	67	66	12-35	24	8.6	24	66.2	M8	0.38	0.28	75	1150	90	0.15	0.6	1.5	8700
		40							0.42	0.31	50	340	50	0.25	1	2	8700	
80	80	78	82	12-44	28	9.8	27	82.9	M10	0.70	0.78	128	1200	80	0.2	0.5	1.5	6900
		84							0.76	0.85	75	400	50	0.25	0.8	2	6900	
150	150	78	82	14-44	28	9.8	27	82.9	M10	0.73	0.82	155	2020	145	0.2	0.5	1.5	6900
		84							0.80	0.89	105	595	85	0.25	0.8	2	6900	
200	200	83	90	16-47	31	10.8	29	90.8	M12	0.89	1.19	175	2500	145	0.2	0.5	1.5	6400
		125							0.95	1.27	120	460	82	0.25	0.8	2	6400	
300	300	94	110	20-60	39	11.8	32.5	110	M12	1.37	2.74	502	6300	280	0.2	0.5	1.5	6000
		145							1.43	2.86	285	1400	145	0.25	0.8	2	6000	
500	500	100	122	25-70	45	13.3	36	122	M12	1.81	4.45	690	7790	100	0.2	0.5	1.5	5000
		145							1.91	4.69	320	970	85	0.25	1	2	5000	

<b>Material</b>	Balg - Edelstahl Nabe - Aluminium
<b>Nabe</b>	Bohrungstoleranz: H7
<b>Temperaturbereich</b>	-30 °C ~ 120 °C
<b>Passfedernut</b>	wahlweise nach DIN 6885 größtmögliche Bohrung mit # gekennzeichnet

# Metallbalgkupplung

mit Adapterflansch

optional  
lasergeschweißt  
optional komplett  
in Edelstahl

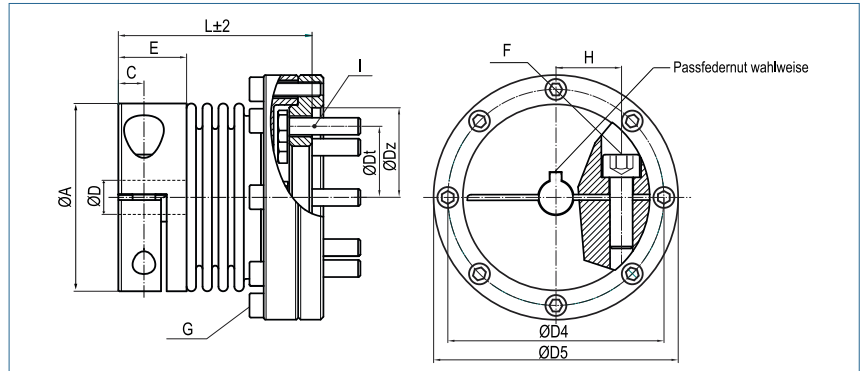

## Bestellbeispiel

**KB4F / 150 - 79 - 30 - 63**

Typ / Größe

Länge  
L

ØD  
(H7)

Dt

Größe	Drehmoment TKN (Nm)	Abmessungen (mm)								Technische Daten								
		L Länge	Ø A Außen- durch- messer	D1 Bohrung (H7) von~bis	H	C	E	D4	F Schraube (ISO4762) TA (Nm)	Masse (kg)	Massen- trägheits- moment J	Federsteifigkeit			Versatz		max Drehzahl (min-1)	
											Torsion CT 10° (Nm/rad)	radial CR (N/mm)	axial CA (N/mm)	radial ΔKr (mm)	axial ΔKa (mm)	Winkel ΔKw (°)		
18	18	63	45	10-25.4	17	5.5	17.5	56.5	M5	0.50	0.15	20	205	50	0.2	0.5	1.5	12800
		71							8	0.52	0.16	15	82	36	0.25	0.5	2	
30	30	61	56	10-32	20	7.3	21	65	M6	0.70	0.20	38	720	50	0.15	0.6	1.5	10300
		69		30#					15	0.72	0.21	28	225	28	0.25	1.0	2	
60	60	68	66	12-35	23	8.6	24	76	M8	1.00	0.65	75	1150	90	0.15	0.6	1.5	8700
		78							40	1.05	0.68	50	340	50	0.25	1.0	2	
150	150	79	82	14-44	28	9.8	27	94	M10	1.65	1.30	155	2020	145	0.2	0.5	1.5	6900
		90							84	1.75	1.37	105	595	85	0.25	0.8	2	
300	300	90	110	30-60	39	11.8	32.5	120	M12	2.90	5.50	502	6300	280	0.2	0.5	1.5	6000
		101							145	3.00	5.62	285	1400	145	0.25	0.8	2	
500	500	100	122	35-70	45	13.3	36	142	M12	4.55	9.00	690	7790	100	0.2	0.5	1.5	5000
		111							145	4.70	9.15	320	970	85	0.25	1	2	
1400	1400	140	157	50-80	55	22.5	55	171	2xM20	10.50	45	1270	700	275	0.2	0.8	1.8	5000
									470									

<b>Material</b>	Balg - Edelstahl Klemmnabe - bis Größe 500: hochfestes Aluminium Klemmnabe - Größe 1400: Stahl Flansche - Stahl
<b>Nabe</b>	Bohrungstoleranz: H7
<b>Temperaturbereich</b>	-30 °C ~ 120 °C -30 °C ~ 250 °C (Größe 1400)
<b>Passfedernut</b>	wahlweise nach DIN 6885 größtmögliche Bohrung mit # gekennzeichnet

Größe	Abmessungen (mm)				
	G Schraube (ISO4762) / TA (Nm)	D5	Dt	Dz	I Schraube (ISO4017) / TA (Nm)
18	8 x M4 / 4.5Nm	63.5	31.5	40	8 x M5 / 7.6Nm
30	8 x M5 / 8Nm	74	40	50	8 x M6 / 13.2Nm
60	8 x M5 / 8Nm	86	50	63	8 x M6 / 13.2Nm
150	8 x M6 / 15Nm	104	63	80	12 x M6 / 13.2Nm
300	12 x M6 / 15Nm	132	80	100	12 x M8 / 31.8Nm
500	12 x M8 / 40Nm	155	100	130	12 x M10 / 63Nm
1400	16 x M8 / 40Nm	184	125	160	12 x M10 / 63Nm

# Metallbalgkupplung

in Halbschalenausführung

optional  
lasergeschweißt  
optional komplett  
in Edelstahl

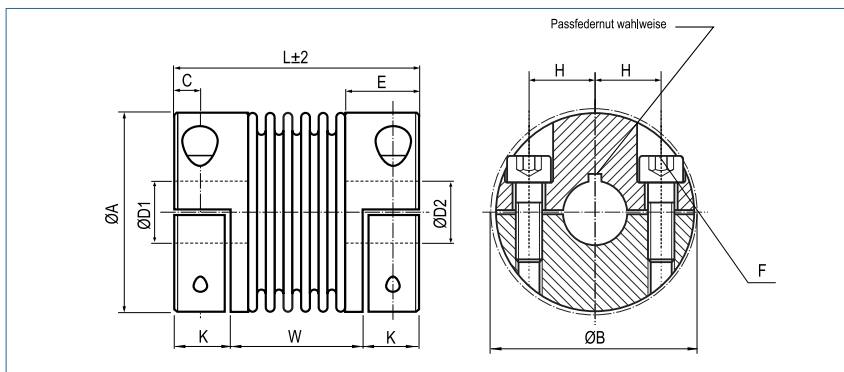

**Bestellbeispiel**

**KB4H / 60 - 83 - 20 - 20 - (S)**

Typ / Größe      Länge L      ØD1 (H7)      ØD2 (H7)      Optionen

Größe	Drehmoment TKN (Nm)	Abmessungen (mm)										Technische Daten								
		Länge (±2)	Ø A	D1/D2 Bohrungen (H7) von-bis	H	C	E	W	K	B	F	Masse (kg)	Massenträgheitsmoment J (g m²)	Federsteifigkeit			Versatz		max Drehzahl min-1	
			Außen-durchmesser						Stör Ø	Schraube (ISO4762) TA (Nm)			Torsion CT 10³ (Nm/rad)	radial CR (N/mm)	axial CA (N/mm)	radial ΔKr (mm)	axial ΔKa (mm)	Winkel ΔKw (°)		
18	18	63	45	10-25.4	17	5.5	19.5	37	13	47.4	M5	0.1	0.04	20	205	50	0.2	0.5	1.5	12800
		71						45			8	0.15	0.05	15	82	36	0.25	0.5	2	12800
30	30	69	56	10-32	20	7.5	27	35	17	56.4	M6	0.3	0.14	38	720	50	0.15	0.6	1.5	10300
		77		30#				43			15	0.32	0.15	28	225	28	0.25	1	2	10300
60	60	83	66	12-35	23	9.5	31	41	21	66.2	M8	0.5	0.28	75	1150	90	0.15	0.6	1.5	8700
		93						51			40	0.6	0.29	50	340	50	0.25	1	2	8700
80	80	94	82	12-44	28	11	36	47	23.5	82.9	M10	0.9	0.65	128	1200	80	0.2	0.5	1.5	6900
		106						59			84	0.95	0.67	75	400	50	0.25	0.8	2	6900
150	150	95	82	14-44	28	11	36	48	23.5	82.9	M10	0.9	0.82	155	2020	145	0.2	0.5	1.5	6900
		107						60			84	0.95	0.86	105	595	85	0.25	0.8	2	6900
200	200	105	90	16-47	31	12.5	41	51	27	90.8	M12	1.3	2.2	175	2500	145	0.2	0.5	1.5	6400
		117						63			125	1.35	2.7	120	460	82	0.25	0.8	2	6400
300	300	111	110	20-60	39	13	41	55	28	110	M12	1.8	4.2	502	6300	280	0.2	0.5	1.5	6000
		125						69			145	1.85	5.2	285	1400	145	0.25	0.8	2	6000
500	500	133	122	25-70	42	15	51	62	35.5	122	M12	2.50	8.6	690	7790	100	0.2	0.5	1.5	5000
		146						75			145	2.51	9.3	320	970	85	0.25	1	2	5000
800	800	168	157	40-80	55	22.5	66.5	77	45.5	168	M20	14.8	57.65	1270	700	275	0.2	0.8	1.8	5000
											400									
1400	1400	168	157	50-80	55	22.5	66.5	77	45.5	168	M20	15.3	58.70	1270	700	275	0.2	0.8	1.8	5000
											400									

<b>Material</b>	Balg - Edelstahl Nabe - bis Größe 500: Aluminium Nabe - ab Größe 800: Stahl
<b>Nabe</b>	Bohrungstoleranz: H7
<b>Temperaturbereich</b>	-30 °C ~ 120 °C Größe 800/1400: -30 °C ~ 250 °C
<b>Passfedernut</b>	wahlweise nach DIN 6885 größtmögliche Bohrung mit # gekennzeichnet

## Metallbalgkupplung

in Halbschalenausführung, kompakt

optional  
lasergeschweißt  
optional komplett  
in Edelstahl

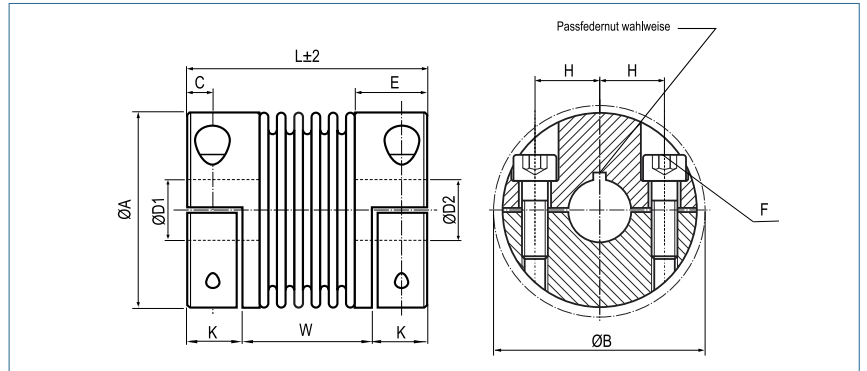

**Bestellbeispiel**    **KB4HC / 60 - 67 - 20 - 20 - (S)**

Typ / Größe                      Länge L                      ØD1 (H7)                      ØD2 (H7)                      Optionen

Größe	Drehmoment TKN (Nm)	Abmessungen (mm)										Technische Daten								
		L	Ø A	D1/D2	H	C	E	W	K	B	F	Masse (kg)	Massenträgheitsmoment J (g m²)	Federsteifigkeit			Versatz			max Drehzahl (min-1)
		Länge	Außen-durchmesser	Bohrungen (H7) von-bis						Stör Ø	Schraube (ISO4762) TA (Nm)			Torsion CT 10³ (Nm/rad)	radial CR (N/mm)	axial CA (N/mm)	radial ΔKr (mm)	axial ΔKa (mm)	Winkel ΔKw (°)	
18	18	58	45	10-25.4	17	5.5	17.5	36	11	47.4	M5	0.07	0.03	20	205	50	0.2	0.5	1.5	12800
		44						8												
30	30	58	56	10-32	20	7.3	21	31	13.5	56.4	M6	0.26	0.13	38	720	50	0.15	0.6	1.5	10300
		39		15				0.27			0.14									
60	60	67	66	12-35	23	8.6	24	33	17	66.2	M8	0.38	0.28	75	1150	90	0.15	0.6	1.5	8700
		43						40			0.42									
80	80	78	82	12-44	28	9.8	27	42	18	82.9	M10	0.70	0.78	128	1200	80	0.2	0.5	1.5	6900
		53						84			0.76									
150	150	78	82	14-44	28	9.8	27	42	18	82.9	M10	0.73	0.82	155	2020	145	0.2	0.5	1.5	6900
		53						84			0.80									
200	200	83	90	16-47	31	10.8	29	43	20	90.8	M12	0.89	1.19	175	2500	145	0.2	0.5	1.5	6400
		54						125			0.95									
300	300	94	110	20-60	39	11.8	32.5	50	22	110	M12	1.37	2.74	502	6300	280	0.2	0.5	1.5	6000
		61						145			1.43									
500	500	100	122	25-70	45	13.3	36	48	26	122	M12	1.81	4.45	690	7790	100	0.2	0.5	1.5	5000
		59						145			1.91									

<b>Material</b>	Balg - Edelstahl Nabe - Aluminium
<b>Nabe</b>	Bohrungstoleranz: H7
<b>Temperaturbereich</b>	-30 °C ~ 120 °C
<b>Passfedernut</b>	wahlweise nach DIN 6885 größtmögliche Bohrung mit # gekennzeichnet

# Metallbalgkupplung

mit Klemmnabe

optional  
lasergeschweißt  
optional komplett  
in Edelstahl

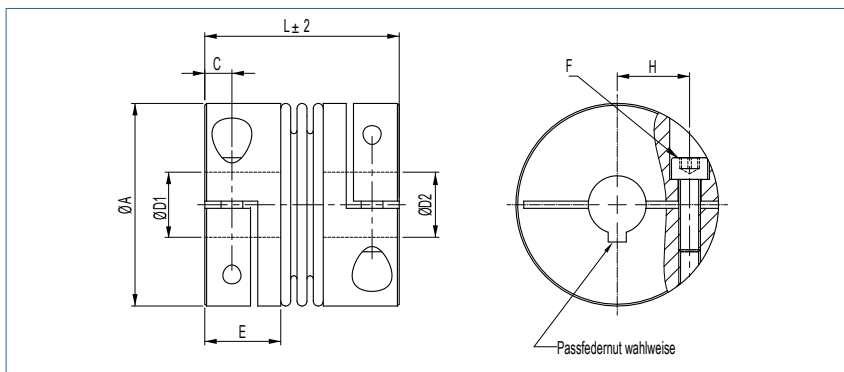

### Bestellbeispiel

**KB4K / 400 - 75 - 44 - 40 - (S)**

Typ / Größe

Länge  
L

ØD1  
(H7)

ØD2  
(H7)

Optionen

Größe	Drehmoment TKN (Nm)	Abmessungen (mm)							Technische Daten								
		L	Ø A	D1/D2	H	C	E	F	Masse (kg)	Massenträgheitsmoment J (g m²)	Federsteifigkeit			Versatz			max Drehzahl min-1
Länge	Außen-durchmesser	Bohrungen (H7) von-bis				Schraube (ISO4762) TA (Nm)			Torsion CT 10³ (Nm/rad)	radial CR (N/mm)	axial CA (N/mm)	radial ΔKr (mm)	axial ΔKa (mm)	Winkel ΔKw (°)			
40	40	46	45	10-25.4	17	5.5	17.5	M5 8	0.07	0.04	3	3350	97	0.05	0.5	0.5	12800
80	80	55	56	12-32 30#	20	7.3	21	M6 15	0.26	0.14	11	6436	165	0.05	0.5	0.5	10300
200	200	60	66	16-35	23	8.6	23	M8 40	0.38	0.28	40	12442	287	0.1	1	0.5	8700
400	400	75	82	32-44	28	9.8	27	M10 84	0.70	0.82	76	6815	338	0.1	1	0.5	6900
650	650	78	90	37-47	39	10.8	29	M12 125	0.89	1.19	103	7910	386	0.1	1.5	1	6400
1000	1000	89	110	42-60	39	11.8	32,5	M12 145	1.37	2.74	1252	29096	756	0.1	1.5	1	6000
1500	1500	96	122	50-70	45	13.3	36	M12 145	1.81	4.45	693	20694	639	0.1	1.5	1	5000

**+**

**Material** Balg - Edelstahl  
Nabe - Aluminium

**Nabe** Bohrungstoleranz: H7

**Temperaturbereich** -30 °C ~ 120 °C

**Passfedernut** wahlweise nach DIN 6885  
größtmögliche Bohrung mit # gekennzeichnet

# Metallbalgkupplung

axial steckbar, mit Klemmnabe

optional  
lasergeschweißt  
optional komplett  
in Edelstahl

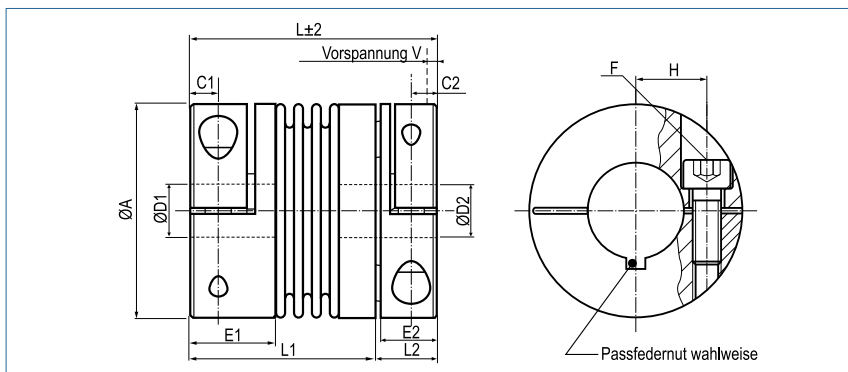
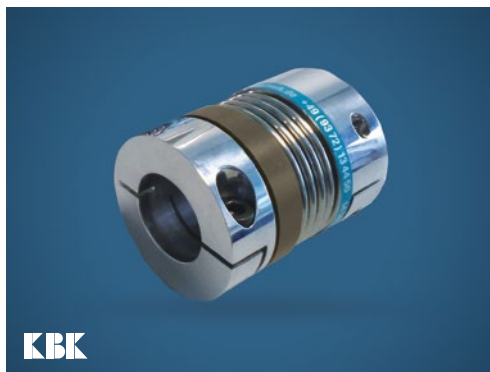

## Bestellbeispiel

**KB4P / 150 - 95 - 44 - 28 - D - (S)**

Typ / Größe                      Länge L                      ØD1 (H7)                      ØD2 (H7)                      Steckung                      Optionen

Größe	Drehmoment TKN (Nm)	Abmessungen (mm)										Technische Daten								
		Länge	Ø A	D1/D2	H	C1	C2	E1	E2	B	F	Schraube (ISO4762) TA (Nm)	Masse (kg)	Massenträgheitsmoment J (g m²)	Torsion CT 10³ (Nm/rad)	radial CR (N/mm)	axial CA (N/mm)	radial ΔKr (mm)	axial ΔKa (mm)	Winkel ΔKw (°)
18	18	62	45	10-24	17	5.5	5.5	17.5	12	47.4	M5	0.14	0.05	20	205	50	0.2	0.5	1.5	12800
		70									8	0.19	0.06	15	82	36	0.25	0.5	2	
30	30	73	56	10-30	20	7.5	7.3	24.5	17	56.4	M6	0.29	0.14	38	720	50	0.15	0.6	1.5	10300
		81									15	0.31	0.15	28	225	28	0.25	1.0	2	
60	60	85	66	12-35	23	10	8.6	29	21	66	M8	0.47	0.33	75	1150	90	0.15	0.6	1.5	8700
		95									40	0.57	0.36	50	340	50	0.25	1.0	2	
80	80	95	82	12-44	28	11	9.8	33.5	21.5	82.9	M10	0.81	0.89	128	1200	80	0.2	0.5	1.5	6900
		106									84	0.90	0.99	75	400	50	0.25	0.8	2	
150	150	95	82	14-44	28	11	9.8	33.5	21.5	82.9	M10	0.91	1.08	155	2020	145	0.2	0.5	1.5	6900
		106									84	1.00	1.18	105	595	85	0.25	0.8	2	
200	200	105	90	16-47	39	13	10.8	38	24	90.8	M12	1.16	1.47	175	2500	145	0.2	0.5	1.5	6400
		117									125	1.26	1.67	120	460	82	0.25	0.8	2	
300	300	114	110	20-60	39	13	10.8	38	27	110	M12	1.68	3.33	502	6300	280	0.2	0.5	1.5	6000
		125									145	1.78	3.53	285	1400	145	0.25	0.8	2	
500	500	136	122	25-70	45	15	13.3	42	42	122	M12	2.50	6.21	690	7790	100	0.2	0.5	1.5	5000
		147									145	2.60	6.41	320	970	85	0.25	1.0	2	



<b>Material</b>	Balg – Edelstahl Nabe - hochfestes Aluminium
<b>Nabe</b>	Bohrungstoleranz: H7
<b>Passfedernut</b>	wahlweise nach DIN 6885
<b>Temperaturbereich</b>	-30 °C ~ 120 °C

Größe	Abmessungen (mm)			
	L1	L2	L3	V
18	48	14	22	0.5-1.0
	56			
30	54	19	31	0.5-1.0
	62			
60	62	23	35	0.5-1.5
	72			
80	71.5	23.5	37.5	0.5-1.5
	82.5			
150	71.5	23.5	37.5	0.5-1.5
	82.5			
200	79	26	42	0.5-1.5
	91			
300	85	29	47	0.5-1.5
	96			
500	92	44	66	0.5-2.0
	103			

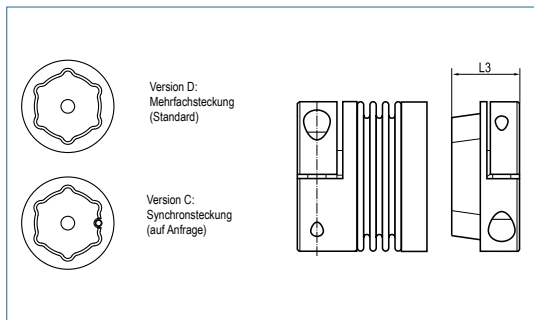

## Metallbalgkupplung

mit Edelstahl-Klemmnabe

optional  
lasergeschweißt

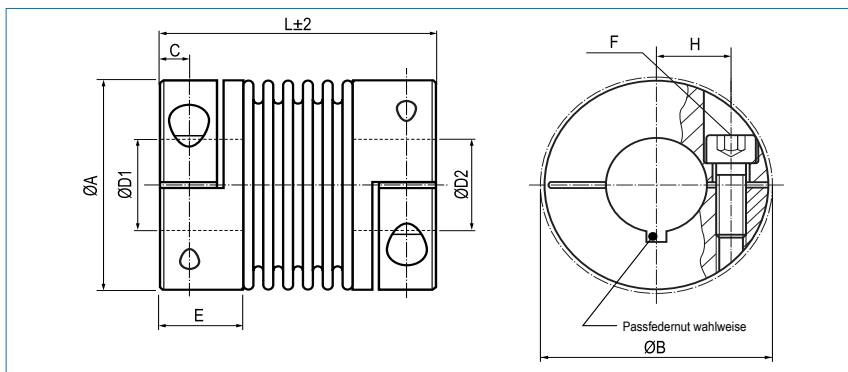

### Bestellbeispiel

**KB4 / 60 - 89 - 12 - 32 - VA/VAW**

Typ / Größe

Länge  
L

ØD1  
(H7)

ØD2  
(H7)

Edelstahl / Edelstahl  
geklebt / lasergeschweißt

Größe	Drehmoment TKN (Nm)	Abmessungen (mm)								Technische Daten								
		L Länge	Ø A Außen- durch- messer	D1/D2 Bohrungen (H7) von-bis	H	C	E	B Stör Ø	F Schraube (ISO4762) TA (Nm)	Masse (kg)	Massen- trägheits- moment J (g m <sup>2</sup> )	Federsteifigkeit			Versatz			max Dreh- zahl min <sup>-1</sup>
											Torsion CT 10° (Nm/rad)	radial CR (N/mm)	axial CA (N/mm)	radial ΔKr (mm)	axial ΔKa (mm)	Winkel ΔKw (°)		
18	18	63	45	10-25.4	17	5.5	19.5	47.4	M5	0.27	0.11	20	205	50	0.2	0.5	1.5	12800
		8							0.41	0.14	15	82	36	0.25	0.5	2	12800	
30	30	65	56	10-32	20	7.5	24.5	56.4	M6	0.83	0.41	38	720	50	0.15	0.6	1.5	10300
		15		0.89					0.44	28	225	28	0.25	1	2	10300		
60	60	79	66	12-35	23	10	29	66	M8	1.4	0.91	75	1150	90	0.15	0.6	1.5	8700
		40							1.7	1.00	50	340	50	0.25	1	2	8700	
80	80	91	82	14-44	28	11	33.5	82.9	M10	2.3	2	128	1200	80	0.2	0.5	1.5	6900
		84							2.4	2.1	75	400	50	0.25	0.8	2	6900	
150	150	91	82	19-44	28	11	33.5	82.9	M10	2.3	2	155	2020	145	0.2	0.5	1.5	6900
		84							2.4	2.1	105	595	85	0.25	0.8	2	6900	
200	200	101	90	22-47	31	13	38	90.8	M12	2.6	3.3	175	2500	145	0.2	0.5	1.5	6400
		125							2.7	3.5	120	460	82	0.25	0.8	2	6400	
300	300	105	110	30-60	40	13	38	110	M12	3.6	7.3	502	6300	280	0.2	0.5	1.5	6000
		145							3.7	7.5	285	1400	145	0.25	0.8	2	6000	
500	500	112	122	35-70	42	15	42	122	M12	5.1	12.4	690	7790	100	0.2	0.5	1.5	5000
		145							5.2	12.7	320	970	85	0.25	1	2	5000	

<b>Material</b>	Balg - Edelstahl Nabe - Edelstahl
<b>Nabe</b>	Bohrungstoleranz: H7
<b>Temperaturbereich</b>	VA -30 °C ~ 120 °C (geklebt) VAW -30 °C ~ 250 °C (lasergeschweißt)
<b>Passfedernut</b>	wahlweise nach DIN 6885 größtmögliche Bohrung mit # gekennzeichnet



# Metallbalgkupplung

mit Innenkonus

optional  
lasergeschweißt  
optional komplett  
in Edelstahl

optional  
chem. vernickelt

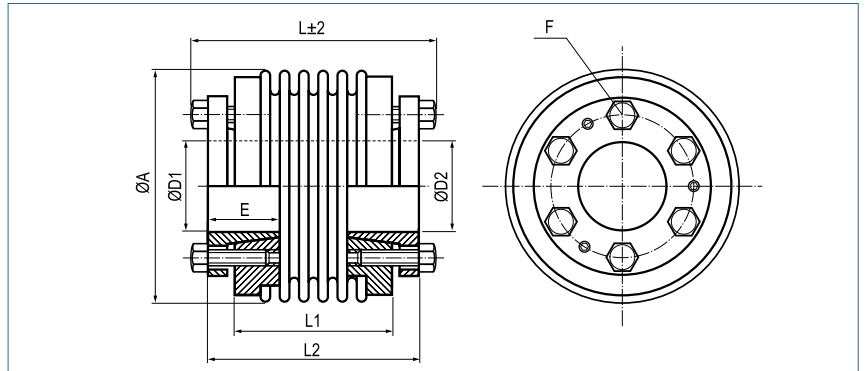

## Bestellbeispiel

**KB5 / 60 - 73 - 20 - 25 - (S)**

Typ / Größe      Länge L      ØD1 (H7)      ØD2 (H7)      Optionen

Größe	Drehmoment TKN (Nm)	Abmessungen (mm)							Technische Daten								
		L Länge (±2)	Ø A Außen-durchmesser	D1/D2 Bohrungen (H7) von-bis	E Nabenlänge	L1	L2	F Schraube (ISO4017) TA (Nm)	Masse (kg)	Massen-trägheitsmoment J (g m²)	Federsteifigkeit			Versatz		max. Drehzahl (min-1)	
										Torsion CT 10³ (Nm/rad)	radial CR (N/mm)	axial CA (N/mm)	radial ΔKr (mm)	axial ΔKa (mm)	Winkel ΔKw (°)		
18	18	63	45	10-18	20	38	56	4xM5	0.36	0.075	20	205	50	0.2	0.5	1.5	11500
		71				46	64	4.5	0.37	0.078	15	82	36	0.25	0.5	2	
30	30	53	56	12-20	20	30	46	6xM5	0.4	0.11	38	720	50	0.15	0.6	1.5	11000
		61				38	54	4.5	0.42	0.12	28	225	25	0.25	1	2	
60	60	62	66	15-25	25	36	54	6xM6	0.77	0.32	75	1150	90	0.15	0.6	1.5	9100
		73				47	65	8.5	0.79	0.34	50	340	50	0.25	1	2	
80	80	78	82	20-35	30	50	70	6xM6	1.34	1.05	128	1200	80	0.2	0.5	1.5	7000
		90				62	82	10	1.39	1.11	75	400	50	0.25	0.8	2	
150	150	78	82	20-35	30	50	70	6xM6	1.36	1.15	155	2020	145	0.2	0.5	1.5	7000
		90				62	82	15	1.41	1.21	105	595	85	0.25	0.8	2	
200	200	78	90	20-40	30	50	70	6xM6	1.59	1.39	175	2500	145	0.2	0.5	1.5	6700
		91				63	83	15	1.66	1.49	120	460	82	0.25	1	2	
300	300	90	110	25-50	37	56	80	6xM8	3.26	4.66	502	6300	280	0.2	0.5	1.5	5200
		102				67	91	17	3.32	4.81	285	1400	145	0.25	1	2	
500	500	101	122	35-55	40	66	90	6xM8	3.78	6.11	690	7790	100	0.2	0.5	1.5	4600
		112				77	101	25	3.87	6.38	320	970	85	0.25	1	2	
800	800	170	157	50-70	60	110	150	6xM16 45	9.05	24.05	760	500	185	0.2	0.8	1.8	3700
1400	1400	170	157	50-70	60	110	150	6xM16 80	9.15	24.2	1270	700	275	0.2	0.8	1.8	3700
3000	3000	206	157	55-85	60	150	190	6xM12 85	9.43	25.7	2810	29450	1300	0.2	0.8	1.5	2800
5000	5000	206	208	60-90	80	146	186	6xM16 210	19.9	96.7	4810	4915	505	0.2	0.8	1.5	2800

<b>Material</b>	Balg – Edelstahl Nabe - Stahl
<b>Nabe</b>	Bohrungstoleranz: H7
<b>Temperaturbereich</b>	-30 °C ~ 120 °C

# Metallbalgkupplung

mit Außenkonus

optional  
lasergeschweißt  
optional komplett  
in Edelstahl

optional  
chem. vernickelt

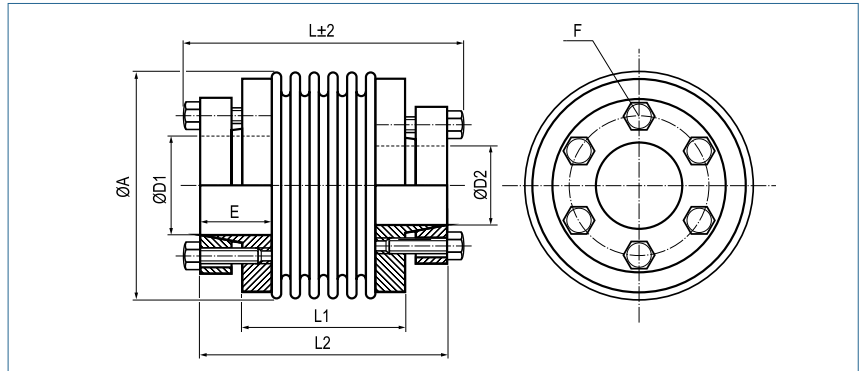

## Bestellbeispiel

**KB6 / 60 - 78 - 20 - 32 - (S)**

Typ / Größe      Länge L      ØD1 (H7)      ØD2 (H7)      Optionen

Größe	Drehmoment TKN (Nm)	Abmessungen (mm)							Technische Daten							max. Drehzahl (min-1)	
		Länge	Ø A	Bohrungen (H7) von-bis	Nabenlänge	L1	L2	F	Masse (kg)	Massenträgheitsmoment J	Federsteifigkeit			Versatz			
							Schraube (ISO4017) TA (Nm)			Torsion CT 10 <sup>3</sup> (Nm/rad)	radial CR (N/mm)	axial CA (N/mm)	radial ΔKr (mm)	axial ΔKa (mm)	Winkel ΔKw (°)		
18	18	65	45	8-15	16.5	37	4x M5	0.3	0.081	20	205	50	0.2	0.5	1.5	11500	
		73				45		5.9	0.31	0.084	15	82	36	0.25	0.5		2
30	30	60	56	12-20	18	31	6x M5	0.37	0.13	38	720	50	0.15	0.6	1.5	11000	
		68				39		5.9	0.39	0.14	28	225	25	0.25	1		2
60	60	78	66	15-32	25	36	6x M5	0.76	0.46	75	1150	90	0.15	0.6	1.5	9100	
		89				47		8.7	0.79	0.49	50	340	50	0.25	1		2
80	80	95	82	20-35	31	50	6x M6	1.57	1.37	128	1200	80	0.2	0.5	1.5	7000	
		107				62		9.9	1.62	1.43	75	400	50	0.25	0.8		2
150	150	95	82	20-35	31	50	6x M6	1.59	1.39	155	2020	145	0.2	0.5	1.5	7000	
		107				62		9.9	1.64	1.45	105	595	85	0.25	0.8		2
200	200	95	90	20-42	31	50	6x M6	1.6	1.64	175	2500	145	0.2	0.5	1.5	6700	
		108				63		10.0	1.67	1.74	120	460	82	0.25	1		2
300	300	108	110	25-50	34	57	6x M8	2.83	4.52	502	6300	280	0.2	0.5	1.5	5200	
		120				68		10.9	2.89	4.68	285	1400	145	0.25	1		2
500	500	122	122	35-55	41	59	6x M8	3.89	7.04	690	7790	100	0.2	0.5	1.5	4600	
		134				70		12.3	3.98	7.31	320	970	85	0.25	1		2
800	800	184	157	50-70	50	108	169	6x M12 85	8.87	24.9	760	500	185	0.2	0.8	1.8	3700
1400	1400	184	157	50-70	50	108	169	6x M12 115	8.92	25.2	1270	700	275	0.2	0.8	1.8	3700
3000	3000	220	157	55-75	60	146	204	6x M12 125	10.9	30.9	2810	2945	305	0.2	0.8	1.5	2800
5000	5000	245	208	60-90	55	146	225	6x M16 210	27.7	144.4	4810	4915	505	0.2	0.8	1.5	2800

<b>Material</b>	Balg – Edelstahl Nabe - Stahl
<b>Nabe</b>	Bohrungstoleranz: H7
<b>Temperaturbereich</b>	-30 °C ~ 120 °C

# Metallbalgkupplung

axial steckbar, mit Außenkonus

optional  
lasergeschweißt  
optional komplett  
in Edelstahl

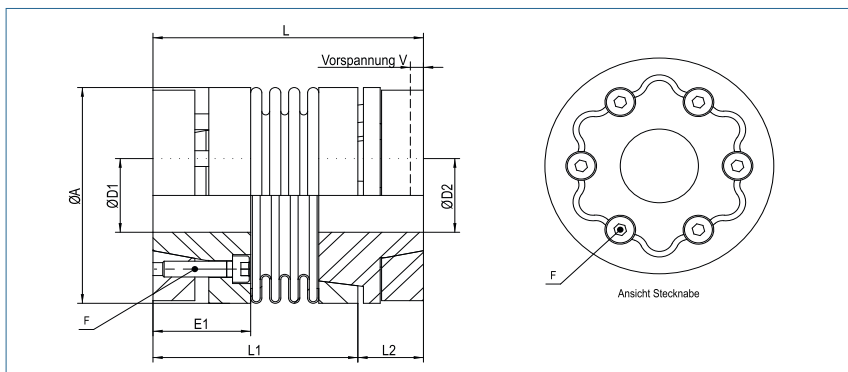

## Bestellbeispiel

**KB6P / 60 - 79 - 20 - 15 - D - (S)**

Typ / Größe      Länge L      ØD1 (H7)      ØD2 (H7)      Steckung      Optionen

Größe	Drehmoment TKN (Nm)	Abmessungen (mm)					Technische Daten									
		L	Ø A	D1	D2	E1	F	Masse (kg)	Massenträgheitsmoment J (g m²)	Federsteifigkeit			Versatz			max. Drehzahl (min-1)
		Länge	Außen-durchmesser	Bohrung (H7) von~bis	Bohrung (H7) von~bis		Schraube (ISO4762) TA (Nm)			Torsion CT 10³ (Nm/rad)	radial CR (N/mm)	axial CA (N/mm)	radial ΔKr (mm)	axial ΔKa (mm)	Winkel ΔKw (°)	
18	18	67	45	8-14	10-22	20.5	M4	0.4	0.1	20	205	50	0.2	0.5	1.5	12800
		75					4.3	0.45	0.11	15	82	36	0.25	0.5	2	
30	30	68	56	10-24	10-24	22	M5	0.48	0.16	38	720	50	0.15	0.6	1.5	10300
		76					6.5	0.5	0.18	28	225	28	0.25	1.0	2	
60	60	79	66	12-32	12-32	24	M5	0.88	0.38	75	1150	90	0.15	0.6	1.5	8700
		89					8	0.98	0.41	50	340	50	0.25	1.0	2	
150	150	97	82	15-40	15-40	35	M6	1.6	1.8	155	2020	145	0.2	0.5	1.5	6900
		108					12	1.69	1.85	105	595	85	0.25	0.8	2	
300	300	113	110	24-56	24-56	35	M8	2.28	4.05	502	6300	280	0.2	0.5	1.5	6000
		125					30	2.38	4.25	285	1400	145	0.25	0.8	2	
500	500	133	122	30-60	30-60	40	M8	3.8	7.55	690	7790	100	0.2	0.5	1.5	5000
		144					32	3.9	7.75	320	970	85	0.25	1.0	2	

<b>Material</b>	Balg - Edelstahl Naben - Aluminium Spannringe - Stahl
<b>Nabe</b>	Bohrungstoleranz: H7
<b>Temperaturbereich</b>	-30 °C ~ 120 °C

Größe	Abmessungen (mm)			
	L1	L2	L3	V
18	52	15	22	0.5-1.0
	60			
30	51.5	16.5	31	0.5-1.0
	59.5			
60	57	22	35	0.5-1.5
	67			
150	73	24	37.5	0.5-1.5
	84			
300	82	31	48	0.5-1.5
	93			
500	90	43	64	0.5-2.0
	101			

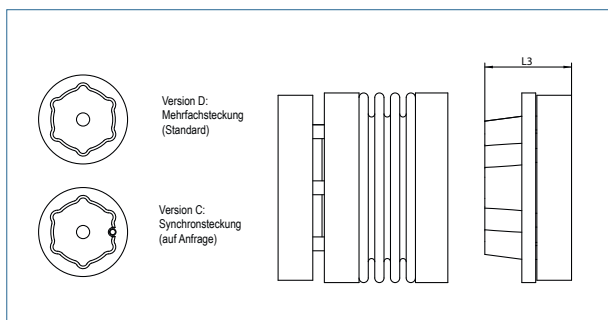

# Metallbalgkupplung

Flanschausführung

optional  
lasergeschweißt  
optional komplett  
in Edelstahl

optional  
chem. vernickelt

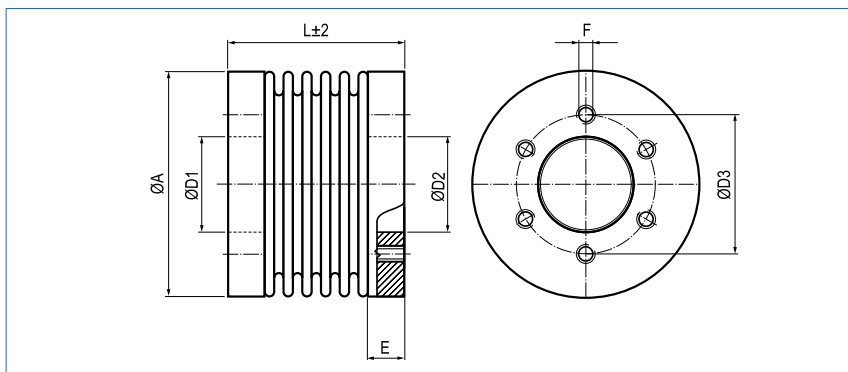
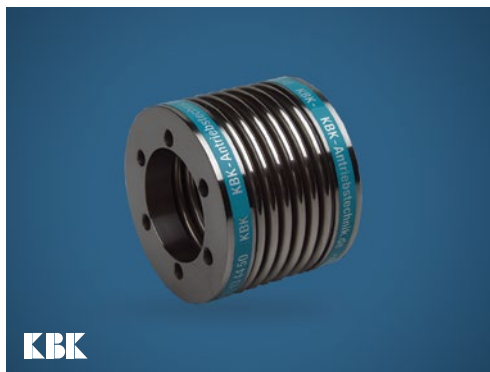

## Bestellbeispiel

**KB7 / 60 - 41 - 38 - (S)**

Typ / Größe

Länge  
L

ØD1/ØD2  
(H7)

Optionen

Größe	Drehmoment TKN (Nm)	Abmessungen (mm)						Technische Daten								
		L	Ø A	Ø D1/D2	Ø D3	E	F	Masse (kg)	Massenträgheitsmoment J (g m <sup>2</sup> )	Federsteifigkeit			Versatz			max. Drehzahl (min <sup>-1</sup> )
		Länge	Außen-durchmesser	Bohrungen (H7) von-bis			Gewinde 6x			Torsion CT 10 <sup>3</sup> (Nm/rad)	radial CR (N/mm)	axial CA (N/mm)	radial ΔKr (mm)	axial ΔKa (mm)	Winkel ΔKw (°)	
18	18	36	45	22	31	6	M5	0.11	0.04	20	205	50	0.2	0.5	1.5	11500
		44						0.115	0.04	15	82	36	0.25	0.5	2	
30	30	30	56	28	37	7	M5	0.16	0.09	38	720	50	0.15	0.6	1.5	11000
		38						0.17	0.09	28	225	25	0.25	1	2	
60	60	41	66	38	46	10.5	M6	0.33	0.25	75	1150	90	0.15	0.6	1.5	9100
		51						0.37	0.29	50	340	50	0.25	1	2	
80	80	50	82	50	62	13	M6	0.69	0.83	128	1200	80	0.2	0.5	1.5	7000
		62						0.75	0.92	75	400	50	0.25	1	2	
150	150	50	82	50	62	13	M6	0.69	0.83	155	2020	145	0.2	0.5	1.5	7000
		62						0.75	0.92	105	595	85	0.25	1	2	
200	200	50	90	50	62	13	M6	0.74	1.0	175	2500	145	0.2	0.5	1.5	6700
		63						0.80	1.1	120	460	82	0.25	1	2	
300	300	55	110	65	80	13	M8	1.18	2.5	502	6300	280	0.2	0.5	1.5	5200
		66						1.24	2.7	285	1400	145	0.25	1	2	
500	500	61	122	70	94	16	M8	1.95	5.0	690	7790	100	0.2	0.5	1.5	4600
		72						2.05	5.3	320	970	85	0.25	1	2	
800	800	131	157	85	110	23	M16	3.55	15	760	500	185	0.2	0.8	1.8	3700
1400	1400	131	157	85	110	23	M16	3.55	15	1270	700	275	0.2	0.8	1.8	3700
3000	3000	131	157	85	110	23	M16	3.70	16	2810	2945	305	0.2	0.8	1.5	2800
5000	5000	146	208	100	130	36.5	M16	8.22	61	4810	4915	505	0.2	0.8	1.5	2800

<b>Material</b>	Balg – Edelstahl Nabe - Stahl
<b>Nabe</b>	Bohrungstoleranz: H7
<b>Temperaturbereich</b>	-30 °C ~ 120 °C

# Metallbalgkupplung

mit Spreiznabe

optional  
lasergeschweißt  
optional komplett  
in Edelstahl

optional  
chem. vernickelt

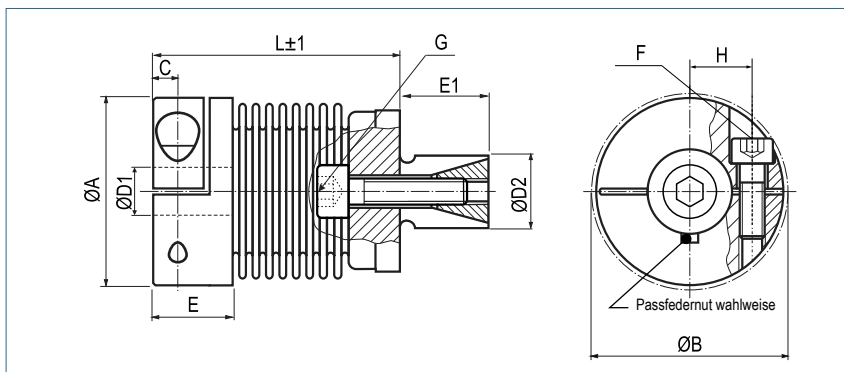

## Bestellbeispiel

**KB8 / 30 - 53 - 15 - 20 - S**  
 Typ / Größe      Länge L      ØD1 (H7)      ØD2 (f7)      Optionen

Größe	Drehmoment TKN (Nm)	Abmessungen (mm)										Technische Daten								
		L Länge	Ø A Außendurchmesser	D1 Bohrung (H7) von-bis	D2 Spreizdorn (f7) von-bis	H	C	E	E1	B Stör Ø	F/G Schraube (ISO4762) TA (Nm)	Masse (kg)	Massenträgheitsmoment J (g m²)	Federsteifigkeit			Versatz			max Drehzahl (min-1)
													Torsion CT 10³ (Nm/rad)	radial CR (N/mm)	axial CA (N/mm)	radial ΔKr (mm)	axial ΔKa (mm)	Winkel ΔKw (°)		
18	18	45	45	10-25.4	13-25	17	5.5	17.5	20	47.4	M5	0.14	0.04	20	205	50	0.2	0.5	1.5	12800
		8										0.15	0.05	15	82	35	0.25	0.5	2	12800
30	30	53	56	10-32	14-30	20	7.5	24.5	25	56.4	M6	0.30	0.15	38	720	50	0.15	0.6	1.5	10300
		15		0.31							0.16	28	225	28	0.25	1.0	2	10300		
60	60	62	66	12-35	23-38	23	10	29	27	66	M8	0.40	0.28	75	1150	90	0.15	0.6	1.5	8700
		40									0.42	0.31	50	340	50	0.25	1.0	2	8700	
150	150	71	82	14-44	26-42	28	11	33.5	32	82.9	M10	0.80	0.90	155	2020	145	0.2	0.5	1.5	6900
		84									0.85	0.95	105	595	85	0.25	0.5	2	6900	
300	300	84	110	20-60	38-60	39	13	38	45	110	M12	1.62	3.28	502	6300	280	0.2	0.5	1.5	6000
		145									1.66	3.37	285	1400	145	0.25	0.8	2	6000	

<b>Material</b>	Balg – Edelstahl Klemmnabe - Aluminium Spreiznabe -Stahl
<b>Nabe und Hohlwelle</b>	Bohrungstoleranz: H7
<b>Passfedernut</b>	wahlweise nach DIN 6885 größtmögliche Bohrung mit # gekennzeichnet
<b>Temperaturbereich</b>	-30 °C ~ 120 °C

## Metallbalgkupplung

axial steckbar, mit Spreiznabe

optional  
lasergeschweißt  
optional komplett  
in Edelstahl

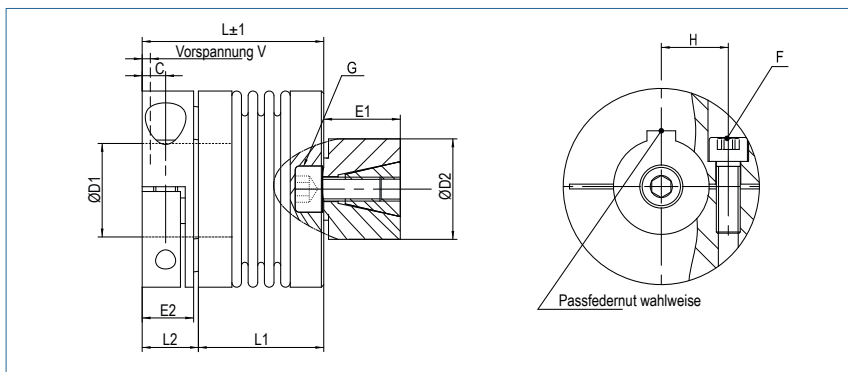

### Bestellbeispiel

**KB8P / 60 - 78 - 15 - 30 - D - (S)**

Typ / Größe      Länge L      ØD1 (H7)      ØD2 (f7)      Steckung      Optionen

Größe	Drehmoment TKN (Nm)	Abmessungen (mm)									Technische Daten								
		L	Ø A	D1	D2	H	C	E2	E1	F/G	Masse (kg)	Massenträgheitsmoment J (g m²)	Federsteifigkeit			Versatz		max Drehzahl (min-1)	
Länge	Außen-durchmesser	Bohrung (H7) von-bis	Spreiz-dorn von-bis					Schraube (ISO4762) TA (Nm)			Torsion CT 10² (Nm/rad)	radial CR (N/mm)	axial CA (N/mm)	radial ΔKr (mm)	axial ΔKa (mm)	Winkel ΔKw (°)			
18	18	47.5	45	10-24	13-25	17	5.5	12	20	M5	0.18	0.04	20	205	50	0.2	0.5	1.5	12800
		54.5								8	0.19	0.05	15	82	36	0.25	0.5	2	12800
30	30	59.5	56	10 32	14-30	20	7.3	17	25	M6	0.33	0.15	38	720	50	0.15	0.6	1.5	10300
		67.5		#30						15	0.34	0.16	28	225	28	0.25	1.0	2	10300
60	60	68	66	12-35	23-38	23	8.6	21	27	M8	0.49	0.28	75	1150	90	0.15	0.6	1.5	8700
		78								40	0.51	0.31	50	340	50	0.25	1.0	2	8700
150	150	75	82	14-44	26-42	28	9.8	21.5	32	M10	0.87	0.90	155	2020	145	0.2	0.5	1.5	6900
		87								84	0.92	0.95	105	595	85	0.25	0.8	2	6900
300	300	93	110	20-60	38-60	39	10.8	27	45	M12	1.87	3.28	502	6300	280	0.2	0.5	1.5	6000
		107								145	1.91	3.37	285	1400	145	0.25	0.8	2	6000



<b>Material</b>	Balg - Edelstahl Klemmnabe - Aluminium Spreiznabe - Stahl
<b>Nabe</b>	Bohrungstoleranz: H7
<b>Temperaturbereich</b>	-30 °C ~ 120 °C
<b>Passfedernut</b>	wahlweise nach DIN 6885 größtmögliche Bohrung mit # gekennzeichnet

Größe	Abmessungen (mm)			
	L1	L2	L3	V
18	33.5	14	22	0.5-1.0
	40.5			
30	40.5	19	31	0.5-1.0
	48.5			
60	45	23	35	0.5-1.5
	55			
150	51.5	23.5	37.5	0.5-1.5
	63.5			
300	64	29	47	0.5-1.5
	78			

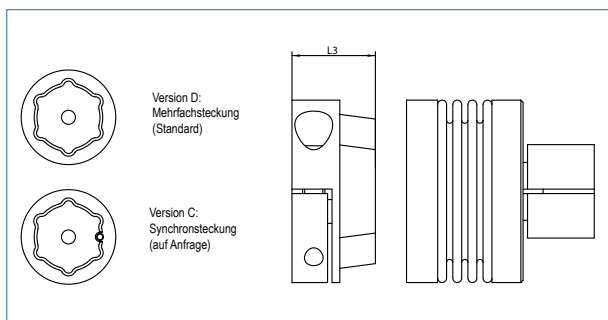

# Elastomerkupplungen

## KBE1 | 5 ~ 48

Elastomerkupplung  
Nabe mit Stiftschraube



S. 32

## KBE2 | 5 ~ 19

Elastomerkupplung  
mit Klemmnabe



S. 33

## KBE2 | 24 ~ 48

Elastomerkupplung  
mit Klemmnabe



S. 34

## KBE2C | 7 ~ 48

Elastomerkupplung  
Kompaktversion



S. 35

## KBE2H | 14 ~ 48

Elastomerkupplung  
Halbschalenausführung



S. 36

## KBE2HC | 14 ~ 48

Elastomerkupplung  
Halbschalenausführung



S. 37

## KBE2D | 7 ~ 38

Elastomerkupplung  
doppelkardanisch mit Klemmnabe



S. 38

## KBE3 | 14 ~ 48

Elastomerkupplung  
mit Außenkonus



S. 39

## KBE3C | 14 ~ 48

Elastomerkupplung  
Kompaktversion mit Außenkonus



S. 40

## KBE4 | 14 ~ 38

Elastomerkupplung  
mit Spreiznabe



S. 41

Elastomerkupplung

mit Stiftschrauben

optional komplett  
in Edelstahl

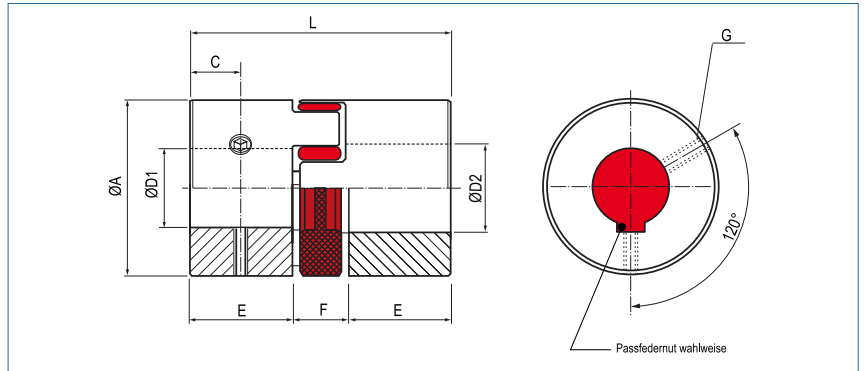
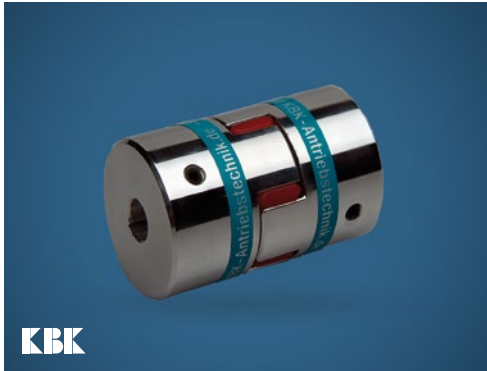

Bestellbeispiel

**KBE1 - 14 - 10 - 12 - 98Sh**

Typ                      Größe                      ØD1 (H7)                      ØD2 (H1)                      Shorehärte

Größe	Abmessungen (mm)						Technische Daten				
	Ø A Außendurchmesser	L Länge	Ø D1-D2 Bohrungen (H7) von-bis	E	F	C	F Schraube (ISO4029) TA (Nm)	Maximal drehzahl rpm. (1/min)	Masse (pro Kupplung) (g)	Massenträgheitsmoment (pro Kupplung) J (g m²)	Drehmoment (Nm)
5	10	15	2 - 6	5	5	2.5	1 x M3 0.5	47500	2.62	0.0000216	0.5
7	14	22	4 - 7	7	8	3.5	2 x M3 1.3	34000	6.5	0.00018	1.2
9	20	30	6 - 9	10	10	5	2 x M3 1.3	24000	22	0.00105	3
14	30	35	6 - 16	11	13	5	1 x M4 3	16000	45	0.006	12.5
19	40	66	10 - 24	25	16	10	1 x M5 6	12000	187	0.040	17
24	55	78	16 - 28	30	18	10	1 x M5 6	8500	420	0.171	60
28	65	90	20 - 38	35	20	15	1 x M6 11	7200	577	0.368	160
38	80	114	20 - 45	45	24	15	1 x M8 25	6000	1200	1125	325
42	95	126	20 - 55	50	26	20	1 x M8 25	4800	1850	16103	450
48	105	140	20 - 60	56	28	20	1 x M8 25	4300	2562	4124	525

**+** **Material**                      Nabe - Aluminium  
    Zahnkranz - Polyurethan  
**Nabe**                              Bohrungstoleranz: H7  
**Passfedernut**                      wahlweise nach DIN 6885  
**Shorehärte**                        bis Größe 9: 92 Sh A (gelb)  
    ab Größe 14: 98 Sh A (rot)  
**Weitere Shorehärten und technische Daten finden Sie auf Seite 42.**



Elastomerkupplung

mit Klemmnabe

optional komplett  
in Edelstahl

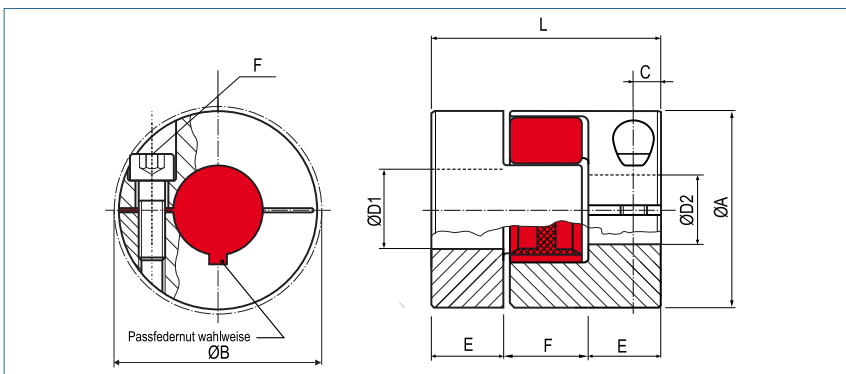

Bestellbeispiel

**KBE2 - 14 - 10 - 12 - 98Sh**

Typ                      Größe                      ØD1 (H7)                      ØD2 (H7)                      Shorehärte

Größe	Abmessungen (mm)								Technische Daten			
	ØA Außen- durch- messer	L Länge	Ø D1-D2 Bohrungen (H7) von-bis	E	F	C	B Stör Ø	F Schraube (ISO4762) TA (Nm)	Maximal- drehzahl rpm. (1/min)	Masse (pro Kupplung) (g)	Massen-träg- heitsmoment (pro Kupplung) J (g m²)	Drehmoment (Nm)
5	10	15	2 - 5	5	5	2.5	11.4	M1.6 0.25	38000	2.52	0.000036	0.5
7	14	22	4 - 7	7	8	3.5	15	M2 0.43	27000	7	0.000195	1.2
9	20	30	4 - 11	10	10	5	23.4	M2.5 0.85	19000	18.52	0.00107	3
14	30	35	4 - 16	11	13	5	32.2	M3 2	13000	59	0.00381	12.5
19	40	66	10 - 22/24*	25	16	12	47	M6 15	10000	183	0.0404	17

Größe	Ø Bohrung (mm)																						
	2	3	4	5	6	7	8	9	10	11	12	13	14	15	16	17	18	19	20	21	22		
5	06	0.6	0.7	0.8																			
7			1.3	1.4	1.5	1.6																	
9			2.3	2.4	2.5	2.7	2.8	2.9	3.0	3.2													
14			7.7	8.0	8.3	8.6	8.9	9.2	9.4	9.7	10	10.3	10.6	10.9	11.2								
19											44	45	47	48	49	50	51	52	54	55	56	57	58

**+** **Material**                      Nabe - Aluminium  
    Zahnkranz - Polyurethan  
**Nabe**                              Bohrungstoleranz: H7  
**Passfedernut**                  wahlweise nach DIN 6885  
**Shorehärte**                      bis Größe 9: 92 Sh A (gelb)  
    ab Größe 14: 98 Sh A (rot)

\* Für Bohrungen > 22H7 bis 24H7 werden die Naben mit 2xM4 gefertigt.  
 Weitere Shorehärten und technische Daten finden Sie auf Seite 42.

# Elastomerkupplung

mit Klemmnabe

optional komplett  
in Edelstahl

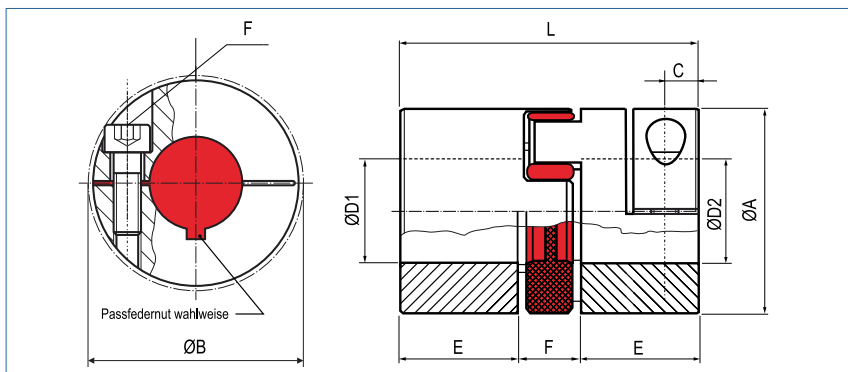

## Bestellbeispiel

**KBE2 - 38 - 20 - 40 - 98Sh**

Typ                      Größe                      ØD1 (H7)                      ØD2 (H7)                      Shorehärte

Größe	Abmessungen (mm)								Technische Daten			
	ØA Außen- durch- messer	L Länge	Ø D1-D2 Bohrungen (H7) von-bis	E	F	C	B Stör Ø	F Schraube (ISO4762) TA (Nm)	Maximal- drehzahl rpm. (1/min)	Masse (pro Kupplung) (g)	Massenträg- heitsmoment J (pro Kupplung) (g m <sup>2</sup> )	Dreh- moment (Nm)
24	55	78	15 - 32	30	18	12	56.4	M6 15	7000	394	0.175	60
28	65	90	19 - 37	35	20	15	72.6	M8 40	6000	624	0.377	160
38	80	114	20 - 48	45	24	20	83.3	M8 40	5000	1230	1.139	325
42	95	126	25 - 50	50	26	20	95	M10 84	4000	1960	2.505	450
48	105	140	25 - 57	56	28	22	105	M12 145	3750	2690	4.175	525

Größe	Ø Bohrung (mm)																												
	15	16	19	20	22	24	25	28	30	32	35	38	39	40	41	42	43	44	45	46	47	48	49	50	51	52	53	54	
24	64	65	69	70	72	74	76	79	81	84																			
28			114	116	119	123	124	130	133	137	142																		
38				135	138	142	144	149	152	156	161	166	168	169	171	173	175	176	178										
42							294	304	310	317	327	337	340	343	347	350	353	357	360	363	367	370	373	376					
48							476	491	500	510	524	539	544	548	553	558	563	568	572	577	582	587	592	596	601	606	611	616	

**+** **Material** Nabe - Aluminium  
Zahnkranz - Polyurethan

**Nabe** Bohrungstoleranz: H7

**Passfedernut** wahlweise nach DIN 6885

**Shorehärte** 98 Sh A (rot)

**Weitere Shorehärten und technische Daten** finden Sie auf Seite 42.

Elastomerkupplung kompakt

optional komplett in Edelstahl

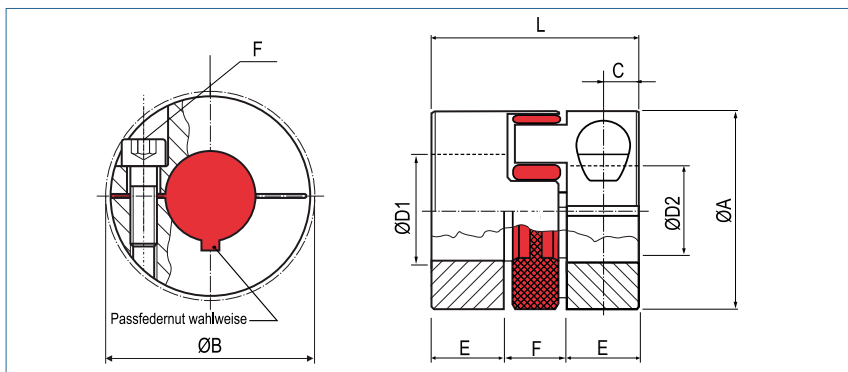

Bestellbeispiel

**KBE2C - 38 - 20 - 40 - 98Sh**

Typ                      Größe                      ØD1 (H7)                      ØD2 (H7)                      Shorehärte

Größe	Abmessungen (mm)								Technische Daten			
	Ø A Außen- durch- messer	L Länge	Ø D1-D2 Bohrungen (H7) von-bis	E	F	C	B Stör Ø	G Schraube (ISO4762) TA (Nm)	Maximal- drehzahl rpm. (1/min)	Masse (pro Kupplung) (g)	Massenträg- heitsmoment J (pro Kupplung) (g m <sup>2</sup> )	Drehmoment (Nm)
7	14	18	3 - 7	5	8	2.5	16.6	M2 0.43	27000	6	0.00018	1.2
9	20	24	4 - 11	7	10	3.5	21.3	M2.5 0.85	19000	15	0.00085	3
14	30	32	4 - 16	9.5	13	5	30.5	M4 4.5	13000	45	0.0166	12.5
19	40	50	8 - 21	17	16	8.5	45.7	M6 15	10000	139	0.0311	17
24	55	58	10 - 32	20	18	10	56.4	M6 15	7000	271	0.119	60
28	65	62	14 - 37	21	20	11	72.6	M8 40	6000	429	0.254	160
38	80	86	15 - 48	31	24	15	83.3	M10 84	5000	888	0.828	325
42	95	94	20 - 50	34	26	17.5	97.6	M12 145	4000	1425	1.866	450
48	105	110	20 - 57	47.5	28	23	105	M12 145	3750	2019	3.221	525

Größe	Ø Bohrung (mm)																									
	3	4	6	8	10	12	14	15	16	18	19	20	24	25	28	30	32	35	38	40	42	45	48	50	55	
7	1.2	1.3	1.5																							
9		2.3	2.5	2.8	3.0																					
14			14	14.7	15.7	16.7	17.7	18.3	18.8																	
19				42	44	47	49	50	51	54	55	56														
24					58	61	63	64	65	67	69	70	74	76	79	81	84									
28							105	107	109	112	114	116	123	124	130	133	137	142	147							
38								241	244	251	254	258	271	274	284	291	297	307	317	324	330	340	350			
42													452	457	471	481	491	505	519	529	539	553	568	577		
48													471	476	491	500	510	524	539	548	558	572	587	596	620	

**+** **Material** Nabe - Aluminium  
Zahnkranz - Polyurethan

**Nabe** Bohrungstoleranz: H7

**Passfedernut** wahlweise nach DIN 6885

**Shorehärte** 98 Sh A (rot)

**Weitere Shorehärten und technische Daten** finden Sie auf Seite 42.

# Elastomerkupplung

Halbschalenausführung

optional komplett  
in Edelstahl

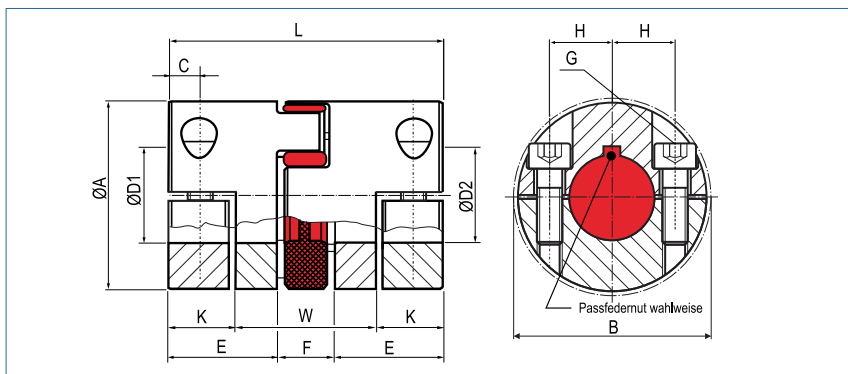
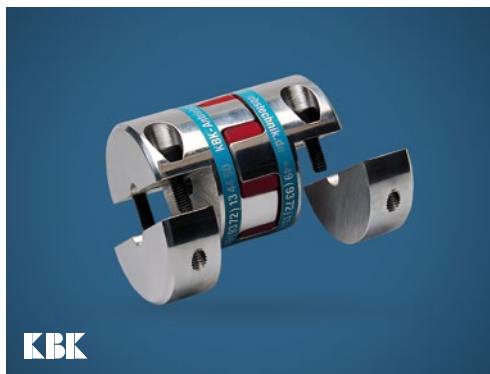

**Bestellbeispiel**

**KBE2H - 19 - 10 - 12 - 98Sh**

Typ                      Größe                      ØD1 (H7)                      ØD2 (H7)                      Shorehärte

Größe	Abmessungen (mm)											Technische Daten				
	Ø A Außen- durch- messer	L Länge	Ø D1/D2 Bohrungen		E	W	F	C	B Stör Ø	H	K	G Schraube (ISO4762) TA (Nm)	Maximal- drehzahl rpm. (1/min)	Masse (pro Kupplung) (g)	Massenträg- heitsmoment (pro Kupplung) J (g m²)	Dreh- moment (Nm)
			min	max												
14	30	35	4	16	11	19	13	5.0	35	10.5	8	M4 5	13000	50	0,007	12.5
19	40	66	8	21	25	27	16	8.0	46	14.5	19.5	M6 15	10000	182	0,042	17
24	55	78	10	32	30	34	18	10.5	57.5	20	22.0	M6 15	7000	391	0,171	60
28	65	90	14	37	35	40	20	11.5	73	25	25.0	M8 40	6000	643	0,402	160
38	80	114	18	48	45	48	24	15.5	83.5	30	33.0	M8 40	5000	1167	1,096	325
42	95	126	22	50	50	53	26	18.0	93.5	32	36.5	M10 84	4000	1943	2,522	450
48	105	140	22	57	56	61	28	18.5	105	36	39.5	M12 145	3750	2592	4,076	525

Größe	Ø Bohrung (mm)																									
	4	6	8	10	11	14	15	16	18	19	20	22	24	25	28	30	32	35	38	40	42	45	46	48	50	55
14	10.3	15.5	20.7	25.8	28.4	36.1	38.7	41.3																		
19			47	59	65	83	89	95	107	113	119															
24				59	65	83	89	95	107	113	119	130	142	148	166	178	190									
28						123	132	141	159	167	176	194	211	220	247	264	282	308								
38									159	167	176	194	211	220	247	264	282	308	335	352	370	396	405	423		
42												370	404	420	471	505	538	589	639	673	706	757	774	807	841	
48												539	588	612	686	735	784	857	931	980	1029	1102	1127	1176	1225	1347

**+** **Material**                      Nabe - Aluminium  
    Zahnkranz - Polyurethan  
**Nabe**                              Bohrungstoleranz: H7  
**Passfedernut**                      wahlweise nach DIN 6885  
**Shorehärte**                        98 Sh A (rot)  
**Weitere Shorehärten und technische Daten**  
**finden Sie auf Seite 42.**

Elastomerkupplung kompakt

Halbschalenausführung

optional komplett  
in Edelstahl

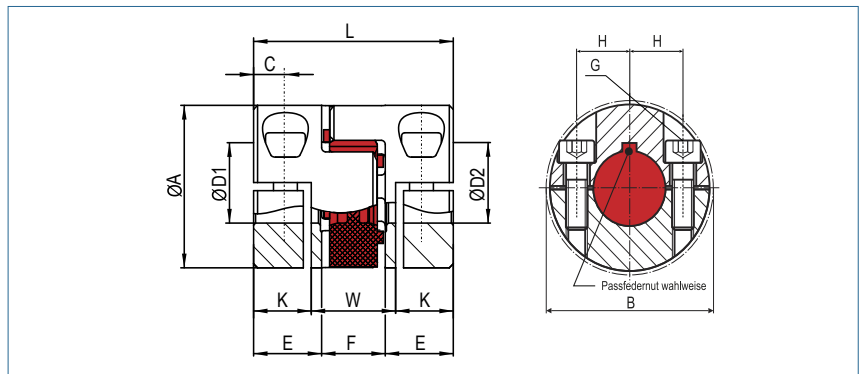

Bestellbeispiel

**KBE2HC - 19 - 10 - 12 - 98Sh**

Typ                      Größe                      ØD1 (H7)                      ØD2 (H7)                      Shorehärte

Größe	Abmessungen (mm)											Technische Daten				
	Ø A Außen- durch- messer	L Länge	Ø D1/D2 Bohrungen		E	W	F	K	C	B	H	G Schraube (ISO4762) TA (Nm)	Maximal- drehzahl rpm. (1/min)	Masse (pro Kupplung) (g)	Massenträg- heitsmoment (pro Kupplung) J (g m²)	Dreh- moment (Nm)
			min	max												
14	30	32	4	16	9.5	16.4	13	7.8	4.5	35	10.5	M4 4.5	13000	47	0.006	12.5
19	40	50	8	21	17	21	16	14.5	8.0	46	14.5	M6 15	10000	79	0.019	17
24	55	58	10	32	20	26	18	16	8	57.5	20	M6 15	7000	280	0.121	60
28	65	62	14	37	21	28	20	17	9	73	25	M8 40	6000	421	0.266	160
38	80	86	18	48	31	38	24	24	12	83.5	30	M8 40	5000	840	0.790	325
42	95	94	22	50	34.5	44	25	25	12.5	93.5	32	M10 84	4000	1416	1.832	450
48	105	110	22	57	41	50	28	30	14	105	36	M12 145	3750	1956	3.101	525

Größe	Ø Bohrung (mm)																									
	4	6	8	10	11	14	15	16	18	19	20	22	24	25	28	30	32	35	38	40	42	45	46	48	50	55
14	10.3	15.5	20.7	25.8	28.4	36.1	38.7	41.3																		
19			47	59	65	83	89	95	107	113	119															
24				59	65	83	89	95	107	113	119	130	142	148	166	178	190									
28						123	132	141	159	167	176	194	211	220	247	264	282	308	335							
38									159	167	176	194	211	220	247	264	282	308	335	352	370	396	405	423		
42												370	404	420	471	505	538	589	639	673	706	757	774	807	841	
48												539	588	612	686	735	784	857	931	980	1029	1102	1127	1176	1225	1347

**+** **Material**                      Nabe - Aluminium  
    Zahnkranz - Polyurethan  
**Nabe**                              Bohrungstoleranz: H7  
**Passfedernut**                      wahlweise nach DIN 6885  
**Shorehärte**                        98 Sh A (rot)  
**Weitere Shorehärten und technische Daten**  
 finden Sie auf Seite 42.

# Elastomerkupplung

doppelkardanisch mit Klemmnabe

optional komplett in Edelstahl

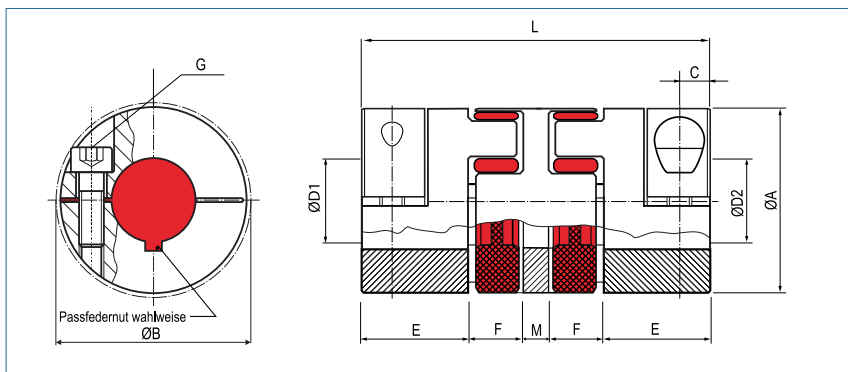

Bestellbeispiel

**KBE2D - 14 - 10 - 12 - 98Sh**

Typ                      Größe                      ØD1 (H7)                      ØD2 (H7)                      Shorehärte

Größe	Abmessungen (mm)									Technische Daten/Nabe			
	ØA	L	Ø D1-D2	E	F	C	B	G	M	Maximaldrehzahl rpm. (1/min)	Masse (pro Kupplung) (g)	Massenträgheitsmoment J (pro Kupplung) (g m²)	Drehmoment (Nm)
7	14	34	4 - 7	7	8	3.5	15	M2 0.43	4	27000	5	0002	1.2
9	20	45	4 - 11	10	10	5	23.4	M2.5 0.85	5	19000	32	0.002	3
14	30	56	4 - 16	11	13	5	32.2	M3 2	8	13000	77	0.010	12.5
19	40	92	10 - 22/24*	25	16	12	45.7	M6 15	10	10000	232	0.056	17
24	55	112	15 - 32	30	18	14	56.6	M6 15	16	7000	534	0.188	60
28	65	128	19 - 37	35	20	15	70.2	M8 40	18	6000	844	0.507	160
38	80	158	20 - 48	45	24	20	82.5	M8 40	20	5000	1580	1.489	325

Größe	Ø Bohrung (mm)																								
	4	5	6	7	8	9	10	11	12	14	15	16	19	20	22	24	25	28	30	32	35	38	40	42	45
7	1.3	1.4	1.5	1.6																					
9	2.3	2.4	2.5	2.7	2.8	2.9	3.0	3.2																	
14	7.7	8.0	8.3	8.6	8.9	9.2	9.4	9.7	10	10.6	10.9	11,2													
19							44	45	47	49	50	51	55	56	58										
24										64	65	69	70	72	74	76	79	81	84						
28												114	116	119	123	124	130	133	137	142					
38														135	138	142	144	149	152	156	161	166	169	173	178

**Material** Nabe - Aluminium  
Zahnkranz - Polyurethan

**Nabe** Bohrungstoleranz: H7

**Passfedernut** wahlweise nach DIN 6885

**Shorehärte** bis Größe 9: 92 Sh A (gelb)  
ab Größe 14: 98 Sh A (rot)

\* Für Bohrungen > 22H7 bis 24H7 werden die Naben mit 2xM4 gefertigt.  
Weitere Shorehärten und technische Daten finden Sie auf Seite 42.

# Elastomerkupplung

mit Außenkonus

optional komplett in Edelstahl

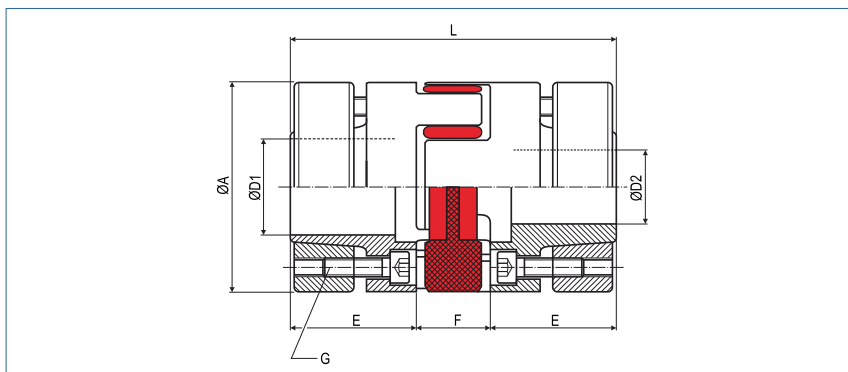

## Bestellbeispiel

**KBE3 - 48 - 40 - 35 - 98Sh**

Typ                      Größe                      ØD1 (H7)                      ØD2 (H7)                      Shorehärte

Größe	Abmessungen (mm)						Technische Daten			
	Ø A Außen- durchmesser	L Länge	Ø D1-D2 Bohrungen (H7) von-bis	E	F	G Schraube (ISO4762) TA (Nm)	Maximal- drehzahl rpm. (1/min)	Masse (pro Kupplung) (g)	Massen- trägheits- moment (pro Kupplung) J (g m²)	Drehmoment (Nm)
14	30	50	6 - 14	18.5	13	M3 1.34	25000	105	0.014	12.5
19	40	66	10 - 20	25	16	M4 2.9	19000	277	0.066	17
24	55	78	15 - 28	30	18	M5 6	14000	612	0.282	60
28	65	90	19 - 38	35	20	M5 6	12000	937	0.650	160
38	80	114	20 - 45	45	24	M6 10	10000	1961	2.005	325
42	95	126	28 - 50	50	26	M8 35	8000	3069	4.322	450
48	105	140	35 - 60	56	28	M8 35	7000	3855	6.851	525

Größe	Ø Bohrung (mm)																						
	6	10	11	14	15	16	19	20	24	25	28	30	32	35	38	40	42	45	48	50	55		
14	8.6	13.8	14.7	22.7																			
19		41	45	62	68	67	83	90															
24					74	72	90	97	112	120	143												
28							189	188	237	250	280	307	310	353	389								
38								269	337	356	398	436	424	501	533	572	585	644					
42											445	506	470	566	581	647	630	728	836	858			
48														955	999	1092	1091	1230	1381	1334	1540		

**+** **Material**                      Nabe - Aluminium  
     Spannung - Stahl  
     Zahnkranz - Polyurethan

**Nabe**                              Bohrungstoleranz: H7

**Shorehärte**                      98 Sh A (rot)

**Weitere Shorehärten und technische Daten**  
 finden Sie auf Seite 42.

# Elastomerkupplung kompakt

mit Außenkonus

optional komplett in Edelstahl

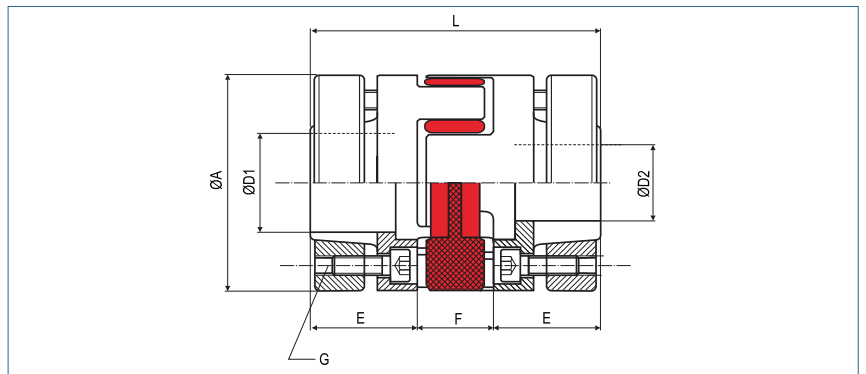

## Bestellbeispiel

**KBE3C - 48 - 40 - 35 - 98Sh**

Typ                      Größe                      ØD1 (H7)                      ØD2 (H7)                      Shorehärte

Größe	Abmessungen (mm)						Technische Daten			
	Ø A Außen- durchmesser	L Länge	Ø D1-D2 Bohrungen (H7) von-bis	E	F	G Schraube (ISO4762) TA (Nm)	Maximal- drehzahl rpm. (1/min)	Masse (pro Kupplung) (g)	Massen- trägheits- moment (pro Kupplung) J (g m <sup>2</sup> )	Drehmoment (Nm)
14	30	42	6 - 14	14.5	13	M3 1.34	25000	91	0.012	12.5
19	40	56	10 - 20	20	16	M4 3	19000	252	0.063	17
24	55	64	14 - 28	23	18	M5 6	14000	492	0.236	60
28	65	76	19 - 38	28	20	M5 6	12000	776	0.535	160
38	80	96	20 - 45	36	24	M6 10	10000	1639	1.686	325
42	95	103	28 - 50	38.5	26	M8 35	8000	2612	3.621	450
48	105	110	30 - 55	41	28	M8 35	7000	3105	5.465	525

Größe	Ø Bohrung (mm)																					
	6	10	11	14	15	16	19	20	24	25	28	30	32	35	38	40	42	45	48	50	55	
14	5.4	7.5	11.3	24.7																		
19		17	20	41	49	36	56	64														
24				47	57	67	98	110	127	139	175											
28							121	133	201	219	248	285	253	307	329							
38								203	304	331	394	452	453	543	550	609	669	634				
42											444	508	535	638	692	763	754	858	964	976		
48												572	638	762	842	929	943	1074	1208	1136	1336	

**+** **Material**                      Nabe - Aluminium  
     Spannung - Stahl  
     Zahnkranz - Polyurethan

**Nabe**                              Bohrungstoleranz: H7

**Shorehärte**                      98 Sh A (rot)

**Weitere Shorehärten und technische Daten**  
 finden Sie auf Seite 42.



## Elastomerkupplung

mit Spreiznabe

optional komplett  
in Edelstahl

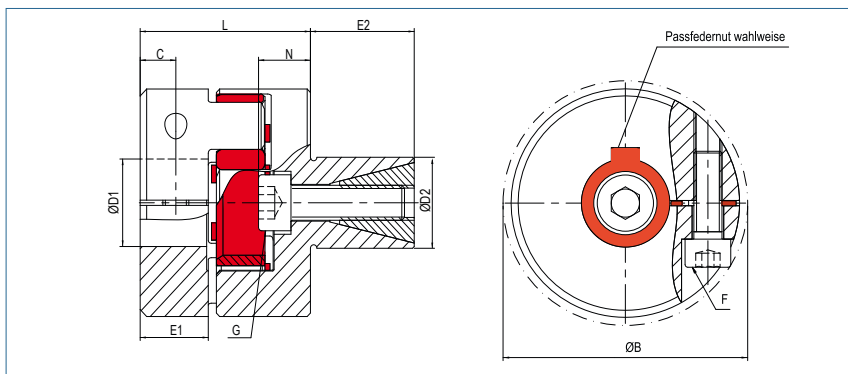

### Bestellbeispiel

**KBE4 - 38 - 40 - 35 - 98Sh**

Typ                      Größe                      ØD1 (H7)                      ØD2 (h7)                      Shorehärte

Größe	Abmessungen (mm)											Technische Daten			
	ØA	L	Ø D1	Ø D2	E1	E2	N	C	B	F	G	Maximaldrehzahl upm. (1/min)	Masse (pro Kupplung) (g)	Massenträgheitsmoment (pro Kupplung) J (g m²)	Drehmoment (Nm)
	Außendurchmesser	Länge	Bohrungen (H7) von-bis	Zapfen (h7) von-bis					Stör Ø	Schraube (ISO4762) TA (Nm)	Schraube (ISO4762) TA (Nm)				
14	30	28	4 - 16	13 - 25	11	20	7	5	32.2	M3 2	M5 9	20000	98	0.010	12.5
19	40	40	10 - 22/24*	14 - 30	17	25	10	9	45.7	M6 15	M6 15	19000	240	0.042	17
24	55	46	12 - 32	23 - 36	20	27	11	10	56.4	M6 15	M8 40	14000	463	0.158	60
28	65	51	19 - 37	26 - 42	21	32	16	11	72.6	M8 40	M10 84	11500	799	0.375	160
38	80	68	20 - 48	38 - 60	31	45	20	15	83.3	M8 40	M12 145	9500	1754	1.213	325

Größe	Ø Bohrung (mm)																						
	4	6	8	9	10	11	12	14	15	16	18	19	20	24	25	28	30	32	35	38	40	42	45
14	7.7	8.3	8.9	9.2	9.4	9.7	10	10.6	10.9	11.2													
19					44	45	47	49	50	51	54	55	56										
24							61	63	64	65	67	69	70	74	76	79	81	84					
28												114	116	123	124	130	133	137	142				
38													135	142	144	149	152	156	161	166	169	173	178

**+** **Material**                      Nabe - Aluminium  
    Spreiznabe - Stahl  
    Zahnkranz - Polyurethan

**Nabe**                              Bohrungstoleranz: H7

**Passfedernut**                      wahlweise nach DIN 6885

**Shorehärte**                        98 Sh A (rot)

\* Für Bohrungen > 22H7 bis 24H7 werden die Naben mit 2xM4 gefertigt.

Weitere Shorehärten und technische Daten finden Sie auf Seite 42.

## Zahnkränze zu Elastomerkupplungen

Typ KBE Serie

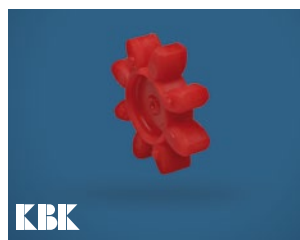

### 80 ShoreA

Dauer temperatur: -50 bis +80  
max. Temp. kurzzeitig: -60 bis +120

### 92 ShoreA

Dauer temperatur: -30 bis +90  
max. Temp. kurzzeitig: -50 bis +120

### 98 ShoreA

Dauer temperatur: -30 bis +90  
max. Temp. kurzzeitig: -40 bis +120

### 64 ShoreD

Dauer temperatur: -20 bis +110  
max. Temp. kurzzeitig: -30 bis +120

Größe	Zahnkranz	Drehmoment [Nm]		Drehfedersteife statisch [Nm/rad]	Drehfedersteife dynamisch [Nm/rad]	Federsteifigkeit radial [N/mm]	Versatz			max. Durchgangsbohrung [mm]
		TK Nenn	TK max				axial [mm]	radial [mm]	angular [Grad]	
5	92 ShA	0.5	0.6	5.16	16	154	+0.4 / -0.2	0.06	1.0°	3
7	80 ShA	0.7	1.4	8.6	26	114	+0.6 / -0.3	0.15	1.1°	3
	92 ShA	1.2	2.4	14.3	43	219	+0.6 / -0.3	0.10	1.0°	
	98 ShA	2	4	22.9	69	421	+0.6 / -0.3	0.10	1.0°	
	64 ShD	2.4	4.8	34.3	103	630	+0.6 / -0.3	0.04	0.8°	
9	80 ShA	1.8	3.6	17.2	52	125	+0.8 / -0.4	0.2	1.1°	7
	92 ShA	3	6	31.5	95	262	+0.8 / -0.4	0.15	1.0°	
	98 ShA	5	10	51.6	155	518	+0.8 / -0.4	0.1	0.9°	
	64 ShD	6	12	74.6	224	739	+0.8 / -0.4	0.05	0.8°	
12	80 ShA	3	6	84.3	252	274	+0.9 / -0.4	0.20	1.1°	8
	92 ShA	5	10	160.4	482	470	+0.9 / -0.4	0.14	1.0°	
	98 ShA	9	18	240.7	718	846	+0.9 / -0.4	0.08	0.9°	
	64 ShD	12	24	327.9	982	1198	+0.9 / -0.4	0.05	0.8°	
14	80 ShA	4	8	60.2	180	153	+1.0 / -0.5	0.21	1.1°	10
	92 ShA	7.5	15	114.6	344	336	+1.0 / -0.5	0.15	1.0°	
	98 ShA	12.5	25	171.9	513	654	+1.0 / -0.5	0.09	0.9°	
	64 ShD	16	32	234.2	702	856	+1.0 / -0.5	0.06	0.8°	
19	80 ShA	6	12	618	1065	582	+1.2 / -0.5	0.15	1.1°	18
	92 ShA	12	24	1090	1815	1120	+1.2 / -0.5	0.10	1.0°	
	98 ShA	21	42	1512	2540	2010	+1.2 / -0.5	0.06	0.9°	
	64 ShD	26	52	2560	3810	2930	+1.2 / -0.5	0.04	0.8°	
24	80 ShA	17	34	860	1390	840	+1.4 / -0.5	0.2	1.0°	27
	92 ShA	35	70	2300	5130	1900	+1.4 / -0.5	0.15	1.0°	
	98 ShA	60	120	3700	8130	2940	+1.4 / -0.5	0.11	0.9°	
	64 ShD	75	150	5030	11500	4200	+1.4 / -0.5	0.08	0.8°	
28	80 ShA	46	92	1370	2350	990	+1.5 / -0.7	0.2	1.3°	30
	92 ShA	95	190	4080	6745	1780	+1.5 / -0.7	0.15	1.0°	
	98 ShA	160	320	6410	9920	3200	+1.5 / -0.7	0.11	0.9°	
	64 ShD	200	400	10260	20177	4348	+1.5 / -0.7	0.08	0.8°	
38	92 ShA	190	380	6525	12000	2350	+1.8 / -0.7	0.17	1.0°	38
	98 ShA	325	650	11800	21850	4400	+1.8 / -0.7	0.12	0.9°	
	64 ShD	405	810	26300	40335	6474	+1.8 / -0.7	0.09	0.8°	
42	92 ShA	265	530	10870	20500	4100	+2.0 / -1.0	0.19	1.0°	46
	98 ShA	450	900	21594	37692	5940	+2.0 / -1.0	0.14	0.9°	
	64 ShD	560	1120	36860	71400	7590	+2.0 / -1.0	0.10	0.8°	
48	92 ShA	310	620	12968	22800	4500	+2.1 / -1.0	0.23	1.0°	51
	98 ShA	525	1050	25759	49400	6820	+2.1 / -1.0	0.16	0.9°	
	64 ShD	655	1310	57630	102800	9000	+2.1 / -1.0	0.11	0.8°	

# Gelenkkupplungen

## KBGK | 18 ~ 100

Gelenkkupplung  
Linearkupplung mit Gewinde



S. 44

## KBGK-T | 18 ~ 100

Gelenkkupplung  
mit Klemmnabe



S. 45

# Distanzkupplungen

## DRE | 14 ~ 48

Distanzkupplung in Halbschalen-  
ausführung mit Elastomersternen



S. 46

## DRB | 4.5 ~ 500

Distanzkupplung in Halbschalen-  
ausführung mit Bälgen



S. 47

# Schalenkupplungen

## KBST

Schalenkupplung  
einfach geschlitzt



S. 48

## KBST - VA

Schalenkupplung  
einfach geschlitzt, Edelstahl



S. 49

## KBST - G

Schalenkupplung  
geteilt



S. 50

## KBST - G - VA

Schalenkupplung  
geteilt, Edelstahl



S. 51

## Gelenkkupplung

Linearkupplung mit Gewinde

optional komplett  
in Edelstahl

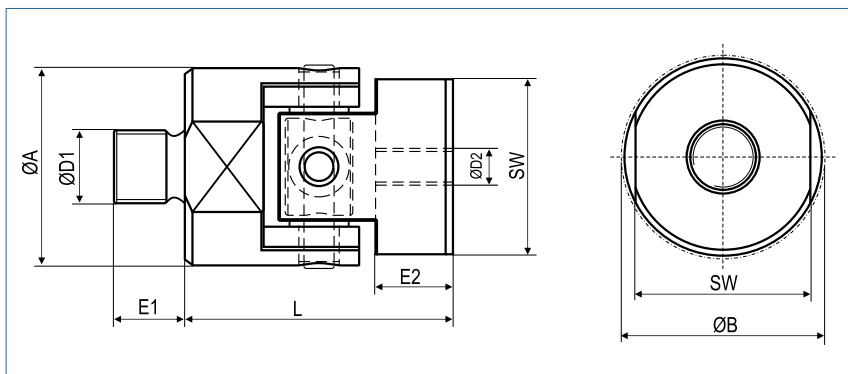

### Bestellbeispiel **KBGK / 27 - M5 - M6**

Typ / Größe

Gewinde  
Zapfen  
Ø D1

Gewinde  
Bohrung  
Ø D2

Größe	Axialkraft F <sub>KA</sub> (N)	Abmessungen (mm)					Technische Daten					
		L Länge	Ø A Außen- durch- messer	SW Schlüssel- weite	E2 max. Einschraub- tiefe	B Stör Ø	Masse (kg)	Massen- trägheitsmoment J (kg mm <sup>2</sup> )	Federsteifigkeit axial CA (N/mm)	Versatz		max Drehzahl min <sup>-1</sup>
18	200	24	18	16	5.5	19	0.013	0.52	8500	1	6	10000
27	800	36	27	24	10.5	30	0.046	4.25	14800	1	6	7500
35	1000	37	35	32	11	39	0.082	12.37	19000	1.5	6	6000
56	4000	60	56	50	15	61	0.31	121	33000	2	6	3750
75	7500	75	74.5	65	25	80	0.87	594	42800	2	6	2850
100	13000	78	100	90	27	106	1.83	2194	62000	2.5	6	2100

Größe	Nabenausführung	Gewindegröße (übertragbare Axialkraft in N)													
		M3	M4	M5	M6	M8	M10	M12	M16	M20	M24	M30	M36	M42	M48
18	Zapfen D1	510	670	857	1017	1380									
	Zapfenlänge E1	5	6	8	8	10									
	Gewinde D2	634	1105	1788	2531	4631									
27	Zapfen D1		670	857	1017	1380	1740								
	Zapfenlänge E1		6	8	8	10	12								
	Gewinde D2	634	1105	1788	2531	4631	7313								
35	Zapfen D1					1380	1740	1970	2710						
	Zapfenlänge E1					10	12	15	20						
	Gewinde D2			1788	2531	4631	7313	10603	9800						
56	Zapfen D1							1970	2710	3386	4064	5142			
	Zapfenlänge E1							15	20	25	30	36			
	Gewinde D2				4631	7313	10603	9800	15400	22140	35344				
75	Zapfen D1									3386	4064	5142	6218		
	Zapfenlänge E1									25	30	36	40		
	Gewinde D2					7313	10603	9800	15400	22140	35344	51390			
100	Zapfen D1											5142	6218	7296	8374
	Zapfenlänge E1											36	40	48	55
	Gewinde D2							10603	9800	15400	22140	35344	51390	70484	92625

**+** **Material**      Innenring - Aluminium  
                          Nabe - Aluminium  
                          Stifte - Stahl

**Temperaturbereich**    -100 °C ~ 250 °C

# Gelenkkupplung

mit Klemmnabe

optional komplett  
in Edelstahl

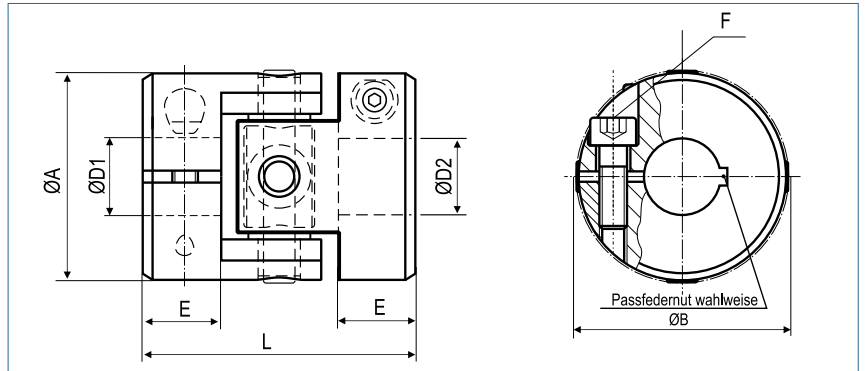

## Bestellbeispiel **KBGK-T / 27 - 6 - 10**

Typ / Größe                      ØD1 (H7)                      ØD2 (H1)

Größe	Drehmoment $T_{KN}$ (Nm)	Drehmoment $T_{kmax}$ (Nm)	Abmessungen (mm)						Technische Daten					
			L	Ø A	D1/D2	B	E	F	Masse (kg)	Massenträgheitsmoment $J$ (kg mm <sup>2</sup> )	Torsionssteifigkeit CT (Nm/rad)	Versatz		max Drehzahl min <sup>-1</sup>
			Länge	Außendurchmesser	Bohrungen (H7)	Stör Ø	Nabellänge	Schraube (ISO 4762) TA (Nm)				radial $\Delta Kr$ (mm)	Winkel $\Delta Kw$ (°)	
18	2	3	24	18	3-10	19	5.5	M2 0.54	0.011	0.526	458	0.6	6	10000
27	5	10	36	27	4-14	30	10.5	M3 1.9	0.040	4.30	802	1	6	7500
35	10	18	37	35	5-20	39	11	M4 4.6	0.069	12.19	1701	1.5	6	6000
56	35	100	53	56	8-32	61	15	M6 15.7	0.278	124	20630	2	6	3750
75	100	250	83	74.5	10-41	80	25	M8 38	0.76	609	51575	2	6	2850
100	250	580	97	100	20-55	106	27	M12 130	1.60	2246	85943	2.5	6	2100

18	Bohrung	3	4	5	6	7	8	9	10				
	Übertr. Moment (Nm)	1.9	2	2.2	2.3	2.4	2.5	2.6	2.8				
27	Bohrung	4	5	6	7	8	9	10	11	12	13	14	
	Übertr. Moment (Nm)	6.9	7.2	7.4	7.7	8	8.3	8.6	8.9	9.2	9.4	9.7	
35	Bohrung	5	6	7	8	9	10	12	14	16	18	20	
	Übertr. Moment (Nm)	16	16.4	16.9	17.4	18	18.5	19.5	20.5	21.6	22.6	23.6	
56	Bohrung	8	10	12	14	16	18	20	22	24	28	32	
	Übertr. Moment (Nm)	57	59	61	64	66	69	72	73	76	80	85	
75	Bohrung	10	12	14	16	18	20	24	28	32	36	40	
	Übertr. Moment (Nm)	143	147	151	156	160	164	173	181	190	199	207	
100	Bohrung	20	22	24	26	28	30	35	40	45	50	55	
	Übertr. Moment (Nm)	475	485	495	505	515	525	550	575	600	625	650	

**Material**                      Innenring - Aluminium  
    Nabe - Aluminium  
    Stifte - Stahl

**Temperaturbereich**      -100 °C ~ 250 °C

# Distanzkupplung

in Halbschalenausführung und mit Elastomerstern

optional  
lasergeschweißt  
optional komplett  
in Edelstahl

optional  
mit Carbonrohr

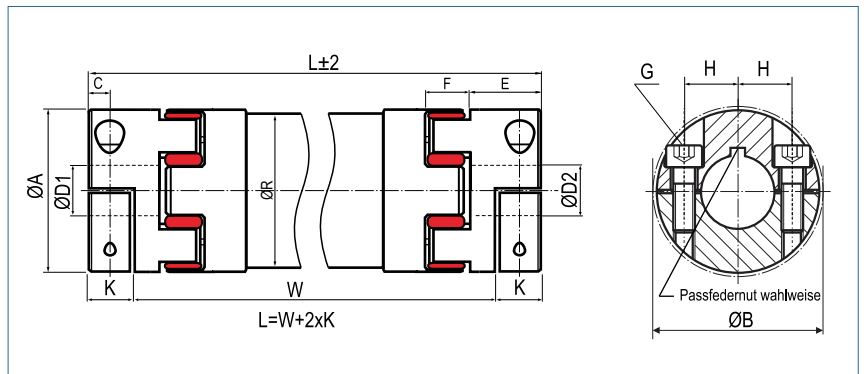

## Bestellbeispiel

**DRE / 19 - 2000 - 10 - 16 - 98Sh**

Typ / Größe      Länge      ØD1 (H7)      ØD2 (H7)      Shorehärte

Größe	Abmessungen (mm)											Technische Daten				
	Ø D1/D2		Ø A	E	K	F	L		R	B	C	H	G (ISO4762)	TKN (Nm)	TKmax (Nm)	CT/m (Nm/rad)
	Bohrungen (H7)	Außen-durchmesser					min	max								
14	4	16	30	11	8	13	102	3000	30	34	5	10.5	M4 5	12.5	25	500
19	8	21	40	25	19.5	16	133	3000	35	46	8.0	14.5	M6 15	17	34	1770
24	10	32	55	30	22.0	18	157	3000	50	57.5	10.5	20	M6 15	60	120	6400
28	14	37	65	35	25.0	20	181	3000	60	73	11.5	25	M8 40	160	320	11400
38	18	48	80	45	33.0	24	229	3000	75	83.5	15.5	30	M8 40	325	650	23000
42	22	50	95	50	36.5	26	253	3000	100	93.5	18.0	32	M10 84	450	900	194000
48	22	57	105	56	39.5	28	281	3000	100	105	18.5	36	M12 145	525	1050	194000

Größe	Ø Bohrung (mm)																									
	4	6	8	10	11	14	15	16	18	19	20	22	24	25	28	30	32	35	38	40	42	45	46	48	50	55
14	10.3	15.5	20.7	25.8	28.4	36.1	38.7	41.3																		
19			47	59	65	83	89	95	107	113	119															
24				59	65	83	89	95	107	113	119	130	142	148	166	178	190									
28						123	132	141	159	167	176	194	211	220	247	264	282	308	335							
38								159	167	176	194	211	220	247	264	282	308	335	352	370	396					
42											370	404	420	471	505	538	589	639	673	706	757	774	807	841		
48											539	588	612	686	735	784	857	931	980	1029	1102	1127	1176	1225	1347	

**Material**      Nabe: Aluminium  
 Zahnkranz: Polyurethan 98 Sh A (rot)  
 Zwischenrohr: Aluminium

**Nabe**            Bohrungstoleranz: H7

**Passfedernut**    wahlweise nach DIN 6885

**Längere Ausführungen bis 6 m auf Anfrage!**

**Informationen zu zulässigen Achsversätzen und maximalen Drehzahlen finden Sie in unseren Betriebs – und Montageanleitungen.**

## Distanzkupplung

in Halbschalenausführung mit Bälgen

optional  
lasergeschweißt  
optional komplett  
in Edelstahl

optional  
mit Carbonrohr

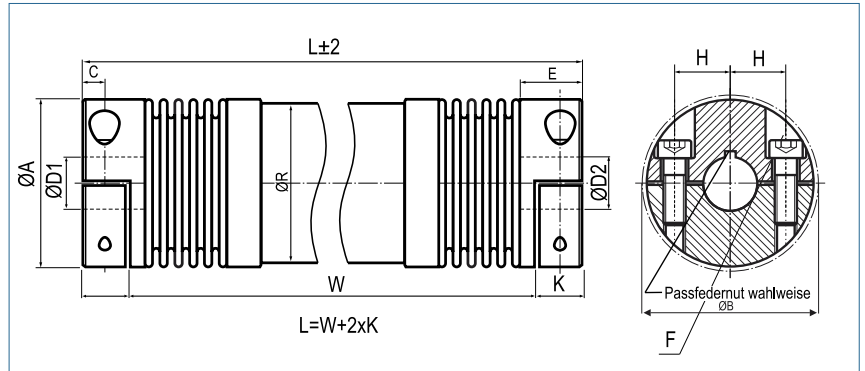

### Bestellbeispiel

**DRB / 60 - 2000 - 15 - 20 - (S)**

Typ / Größe

Länge

ØD1  
(H7)

ØD2  
(H7)

Optionen

Größe	Drehmoment TKN (Nm)	Abmessungen (mm)										Technische Daten		
		L		Ø A	D1/D2	H	C	E	K	F	R	B	Federsteifigkeit	
		min	max	Außendurchmesser	Bohrungen (H7)					Schraube (ISO4762) TA (Nm)	Rohr Ø	Stör Ø	Torsion Bälge C <sub>T</sub> 10 <sup>3</sup> (Nm/rad)	Torsion Rohr C <sub>T</sub> 10 <sup>3</sup> (Nm/rad)
4.5	4.5	68	3000	32.5	6-16	12	5	14	8.5	M4 35	30	34	3.2	0.5
10	10	82	3000	40.5	6-25	15.5	5	14	9	M4 45	35	41.5	4.1	1.8
18	18	108	3000	45	10-25.4	17	5.5	19.5	13	M5 8	35	47.4	10	1.8
30	30	111	3500	56	10-30	20	7.5	27	17	M6 15	50	56.4	19	6.5
60	60	135	4000	66	12-35	23	9.5	31	21	M8 40	60	66	37.5	11.5
150	150	154	4000	82	14-44	28	11	36	23.5	M10 84	75	82.9	77.5	23
200	200	169	4000	90	16-48	31	12.5	41	27	M12 125	90	90.8	87.5	73
300	300	179	4000	110	20-60	39	13	43	28	M12 145	100	110	251	194
500	500	215	4000	122	25-65	42	15	51	35.5	M12 145	100	122	345	194



**Material** Balg - Edelstahl  
Naben - Aluminium  
Zwischenrohr - Aluminium

**Passfedernut** wahlweise nach DIN 6885

**Temperaturbereich** -30 °C ~ 120°C

**Längere Ausführungen bis 6 m auf Anfrage!**

**Eine Balgbruchsicherung ist automatisch integriert.**

**Informationen zu zulässigen Achsversätzen und maximalen Drehzahlen finden Sie in unseren Betriebs – und Montageanleitungen.**

## Schalenkupplungen

einfach geschlitz

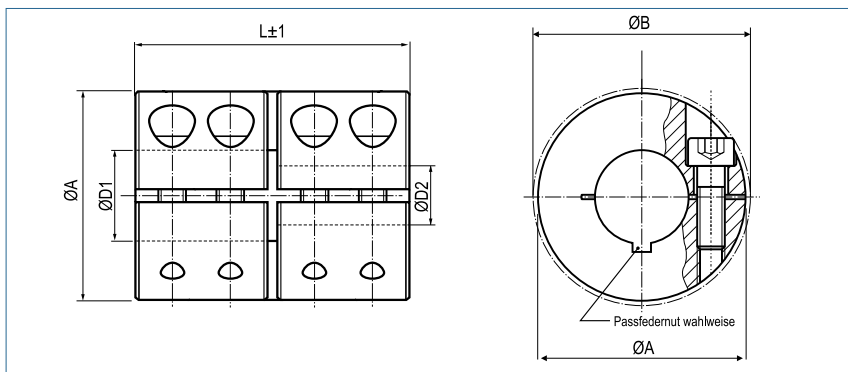

Bestellbeispiel für Standardkupplung

**KBST - 50**

Diese Kupplung wird automatisch mit durchgängiger Bohrung 50H7 geliefert.

Typ Größe

Bestellbeispiel für Kupplung mit unterschiedlichen Bohrungen

**KBST - 50 - 45 - 48**

Diese Kupplung entspricht den Abmessungen der KBST-50 und wird mit der Bohrungskombination 45H7 - 48H7 geliefert.

Typ Größe D1 D2

KBST Schalenkupplung - Stahl brüniert									
Größe	Drehmoment Stahl Nm	Abmessungen - Dimensions					Schrauben (ISO4762)	Anzugsmoment der Schrauben Nm	Gewicht g
		Standard-bohrung D1 / D2 H7	abgesetzte Bohrung von-bis	A mm	B mm	L mm			
6	30	6	5-7	18	21.2	30	M3x8	2	47
8	50	8	5-12	24	26.8	35	M3x10	3	102
10	100	10	5-15	29	32.7	45	M4x12	4.5	185
12	100	12	5-15	29	32.7	45	M4x12	4.5	180
14	190	14	10-17	34	39.1	50	M5x16	9	272
15	190	15	10-17	34	39.1	50	M5x16	9	266
16	190	16	10-17	34	39.1	50	M5x16	9	261
20	350	20	10-24	42	48.2	65	M6x16	15	518
25	390	25	10-26	45	50.8	75	M6x16	15	623
30	475	30	20-32	53	58.1	83	M6x18	15	920
35	1100	35	20-40	67	74.1	95	M8x25	40	1880
40	1325	40	30-50	77	83.4	108	M8x25	40	2710
50	2250	50	40-52	85	93.2	124	M10x25	84	3520

Größe	Ø Bohrung (mm)																						
	5	6	8	10	12	14	16	18	20	22	24	26	28	30	32	34	36	38	40	44	46	48	50
6	18	19																					
8	25	26	29	31	33																		
10	51	53	57	61	65	69																	
12	51	53	57	61	65	69																	
14				109	116	122	129																
15				109	116	122	129																
16				109	116	122	129																
20				195	205	214	223	233	242	251	261												
25				209	219	228	237	247	256	265	275	284											
30									284	293	303	312	321	330	340								
35									582	599	616	632	649	666	682	699	716	732	749				
40														749	765	782	799	815	832	865	882	899	915
50																			1400	1453	1479	1506	1532

**+** Passfedernuten nach DIN 6885/1 sind nur bei durchgängigen Bohrungen möglich.



## Schalenkupplungen

einfach geschlitzt, in Edelstahl

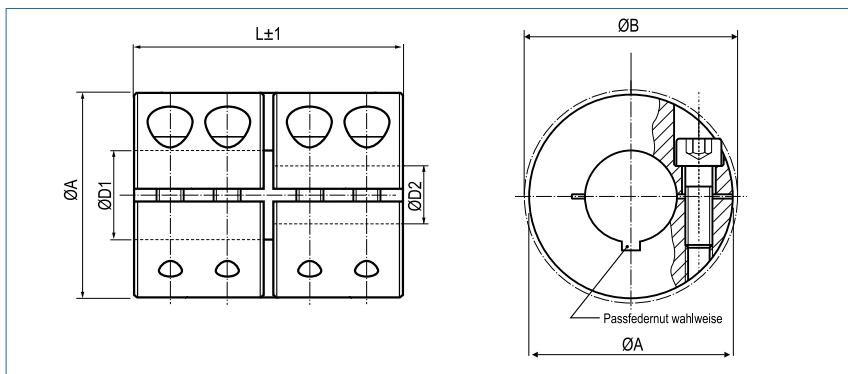

Bestellbeispiel für Standardkupplung

**KBST-VA - 50**

Diese Kupplung wird automatisch mit durchgängiger Bohrung 50H7 geliefert.

Typ Größe

Bestellbeispiel für Kupplung mit unterschiedlichen Bohrungen

**KBST-VA - 50 - 45 - 48**

Diese Kupplung entspricht den Abmessungen der KBST-50 und wird mit der Bohrungskombination 45H7 - 48H7 geliefert.

Typ Größe D1 D2

Schalenkupplung - Edelstahl rostfrei									
Größe	Drehmoment Edelstahl Nm	Abmessungen - Dimensions					Schrauben (ISO4762)	Anzugsmoment der Schrauben Nm	Gewicht g
		Standardbohrung D1 / D2 H7	abgesetzte Bohrungen von-bis	A mm	B mm	L mm			
6	25	6	5-7	18	21.2	30	M3x8	1.6	47
8	40	8	5-12	24	26.8	35	M3x10	1.6	102
10	90	10	5-15	29	32.7	45	M4x12	3.9	185
12	90	12	5-15	29	32.7	45	M4x12	3.9	180
14	160	14	10-17	34	39.1	50	M5x16	7.6	272
15	160	15	10-17	34	39.1	50	M5x16	7.6	266
16	160	16	10-17	34	39.1	50	M5x16	7.6	261
20	300	20	10-24	42	48.2	65	M6x16	13.2	518
25	325	25	10-26	45	50.8	75	M6x16	13.2	623
30	400	30	20-32	53	58.1	83	M6x18	13.2	920
35	925	35	20-40	67	74.1	95	M8x25	32	1880
40	1100	40	30-50	77	83.4	108	M8x25	32	2710
50	1875	50	40-52	85	93.2	124	M10x25	63	3520

Größe	Ø Bohrung (mm)																				
	5	6	8	10	12	14	18	20	24	26	28	30	32	38	40	42	44	46	48	50	52
6	15	16																			
8	21	22	23	25	27																
10	44	45	49	52	56	59															
12	44	45	49	52	56	59															
14				93	98	104															
15				93	98	104															
16				93	98	104															
20				167	175	183	199	207	223												
25				179	187	195	211	219	235	243											
30								243	259	267	274	282	290								
35								510	539	553	568	582	597	641	655						
40											655	670	713	728	743	757	772	786	801		
50														1226	1250	1273	1296	1319	1342	1365	

**+** Passfedernuten nach DIN 6885/1 sind nur bei durchgängigen Bohrungen möglich.

## Schalenkupplungen

geteilt

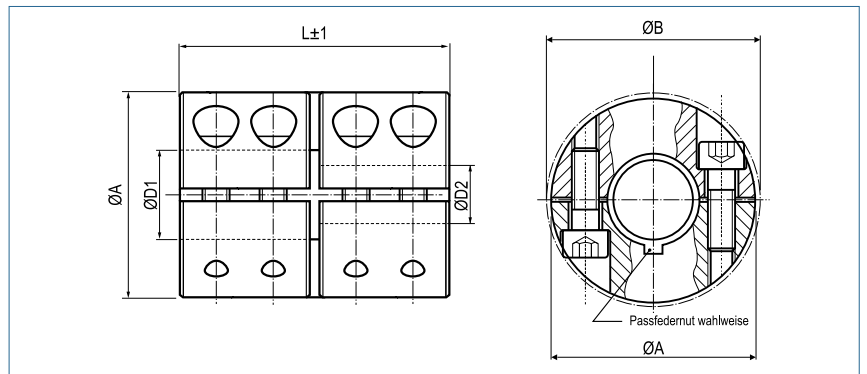

Bestellbeispiel für Standardkupplung

**KBST-G - 50**

Typ Größe

Diese Kupplung wird automatisch mit durchgängiger Bohrung 50H7 geliefert.

Bestellbeispiel für Kupplung mit unterschiedlichen Bohrungen

**KBST-G - 50 - 45 - 48**

Typ Größe D1 D2

Diese Kupplung entspricht den Abmessungen der KBST-G-50 und wird mit der Bohrungskombination 45H7 - 48H7 geliefert.

Schalenkupplung geteilt - Stahl brüniert									
Größe	Drehmoment Stahl Nm	Abmessungen - Dimensions					Schrauben (ISO4762)	Anzugsmoment der Schrauben Nm	Gewicht g
		Standard- bohrung D1 / D2 H7	abgesetzte Bohrung von-bis	A mm	B mm	L mm			
6	30	6	5-7	18	21.2	30	M3x8	2	47
8	50	8	5-12	24	26.8	35	M3x10	3	102
10	100	10	5-15	29	32.7	45	M4x12	4.5	185
12	100	12	5-15	29	32.7	45	M4x12	4.5	180
14	190	14	10-17	34	39.1	50	M5x16	9	272
15	190	15	10-17	34	39.1	50	M5x16	9	266
16	190	16	10-17	34	39.1	50	M5x16	9	261
20	350	20	10-24	42	48.2	65	M6x16	15	518
25	390	25	10-26	45	50.8	75	M6x16	15	623
30	475	30	20-32	53	58.1	83	M6x18	15	920
35	1100	35	20-40	67	74.1	95	M8x25	40	1880
40	1325	40	30-50	77	83.4	108	M8x25	40	2710
50	2250	50	40-52	85	93.2	124	M10x25	84	3520

Größe	Ø Bohrung (mm)																				
	5	6	8	10	12	14	16	18	20	22	26	28	30	32	34	38	42	44	48	50	52
6	29	35																			
8	29	35	47	58	70																
10	52	62	83	103	124	145															
12	52	62	83	103	124	145															
14				168	202	235	269														
15				168	202	235	269														
16				168	202	235	269														
20				237	284	332	379	427	474	521											
25				237	284	332	379	427	474	521	616										
30									474	521	616	664	711	758							
35									847	932	1102	1186	1271	1356	1441	1610					
40													1271	1356	1441	1610	1780	1864	2034	2119	
50																	2825	2960	3229	3363	3498

**+** Passfedernuten nach DIN 6885/1 sind bei allen Bohrungskombinationen möglich.

## Schalenkupplungen

geteilt, in Edelstahl

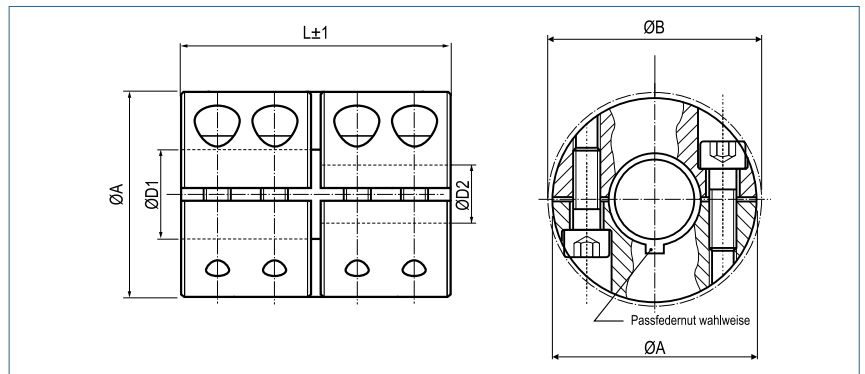

Bestellbeispiel für Standardkupplung

**KBST-G-VA - 50**

Diese Kupplung wird automatisch mit durchgängiger Bohrung 50H7 geliefert.

Typ

Größe

Bestellbeispiel für Kupplung mit unterschiedlichen Bohrungen

**KBST-G-VA - 50 - 45 - 48**

Diese Kupplung entspricht den Abmessungen der KBST-G-50 und wird mit der Bohrungskombination 45H7 - 48H7 geliefert.

Typ

Größe

D1

D2

KBST - G - VA Schalenkupplung geteilt - Edelstahl rostfrei									
Größe	Drehmoment Edelstahl Nm	Abmessungen - Dimensions					Schrauben (ISO4762)	Anzugsmoment der Schrauben Nm	Gewicht g
		Standard-bohrung D1 / D2 H7	abgesetzte Bohrungen von-bis	A mm	B mm	L mm			
6	25	6	5-7	18	21.2	30	M3x8	1.6	47
8	40	8	5-12	24	26.8	35	M3x 10	1.6	102
10	90	10	5-15	29	32.7	45	M4x 12	3.9	185
12	90	12	5-15	29	32.7	45	M4x 12	3.9	180
14	160	14	10-17	34	39.1	50	M5x 16	7.6	272
15	160	15	10-17	34	39.1	50	M5x 16	7.6	266
16	160	16	10-17	34	39.1	50	M5x 16	7.6	261
20	300	20	10-24	42	48.2	65	M6x 16	13.2	518
25	325	25	10-26	45	50.8	75	M6x 16	13.2	623
30	400	30	20-32	53	58.1	83	M6x 18	13.2	920
35	925	35	20-40	67	74.1	95	M8x 25	32	1880
40	1100	40	30-50	77	83.4	108	M8x 25	32	2710
50	1875	50	40-52	85	93.2	124	M10x 25	63	3520

Größe	Ø Bohrung (mm)																			
	5	6	12	14	16	18	20	22	24	28	30	32	34	36	38	40	44	46	50	52
6	24	29																		
8	24	29	57																	
10	44	53	106	124																
12	44	53	106	124																
14			172	200	229															
15			172	200	229															
16			172	200	229															
20			243	284	324	365	405	446	486											
25			243	284	324	365	405	446	486											
30							405	446	486	567	608	648								
35							742	816	890	1038	1112	1186	1261	1335	1409	1483				
40											1112	1186	1261	1335	1409	1483	1631	1706	1854	
50																2357	2593	2711	2946	3064

**+** Passfedernuten nach DIN 6885/1 sind bei allen Bohrungskombinationen möglich.

Fragen Sie uns nach unseren Katalogen  
für **SICHERHEITSKUPPLUNGEN** und  
**WELLE-NABE-VERBINDUNGEN**

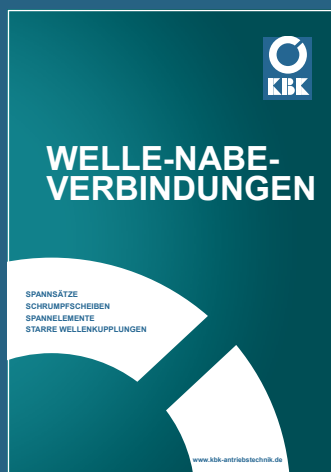

**KBK Antriebstechnik GmbH**

Unterlandstraße 46

63911 Klingenberg am Main

Tel.: +49 9372 94061-0

Fax: +49 9372 94061-29

[info@kbk-antriebstechnik.de](mailto:info@kbk-antriebstechnik.de)

[www.kbk-antriebstechnik.de](http://www.kbk-antriebstechnik.de)